

DETAILS 'M'

A

B

C

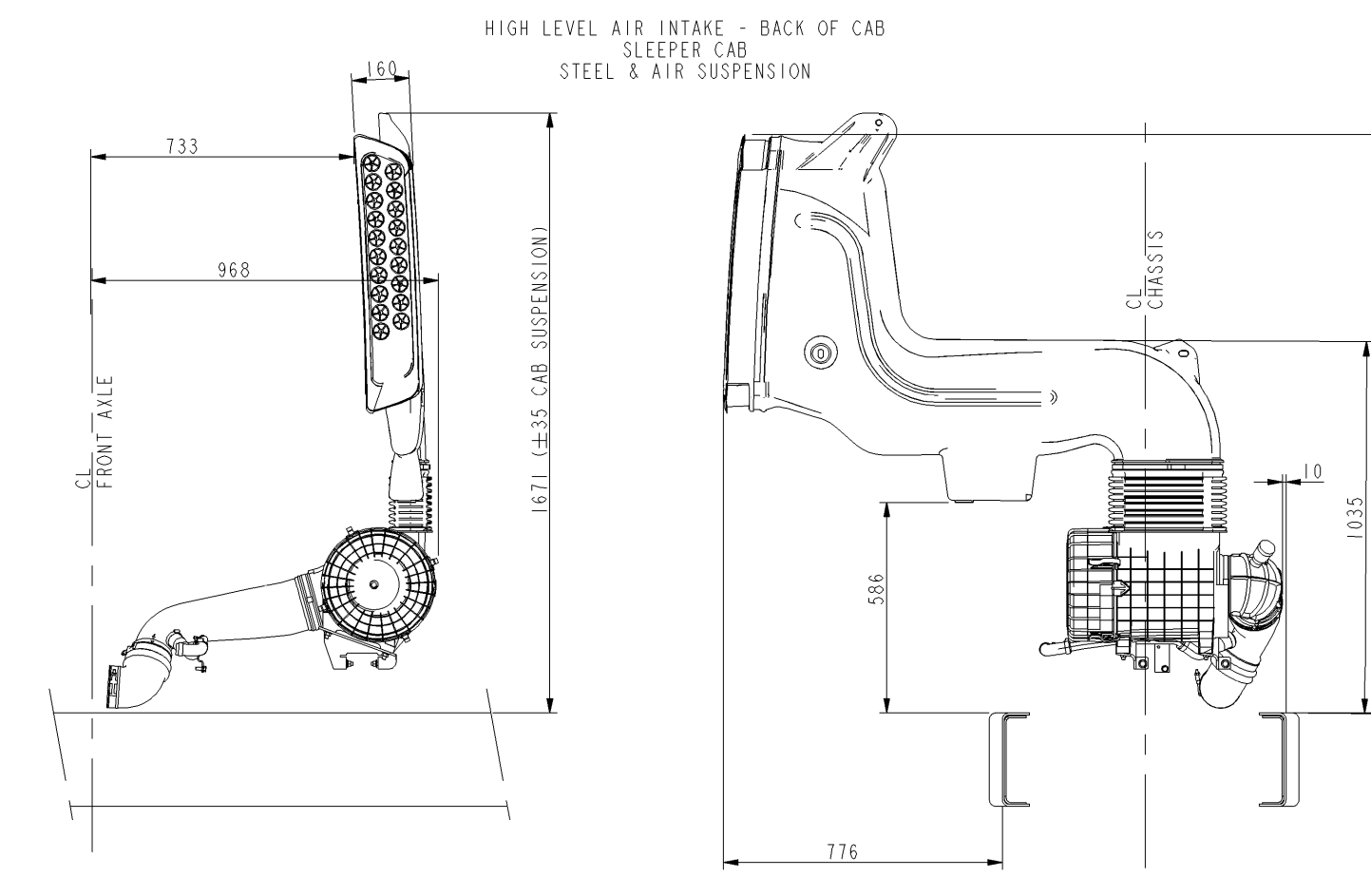
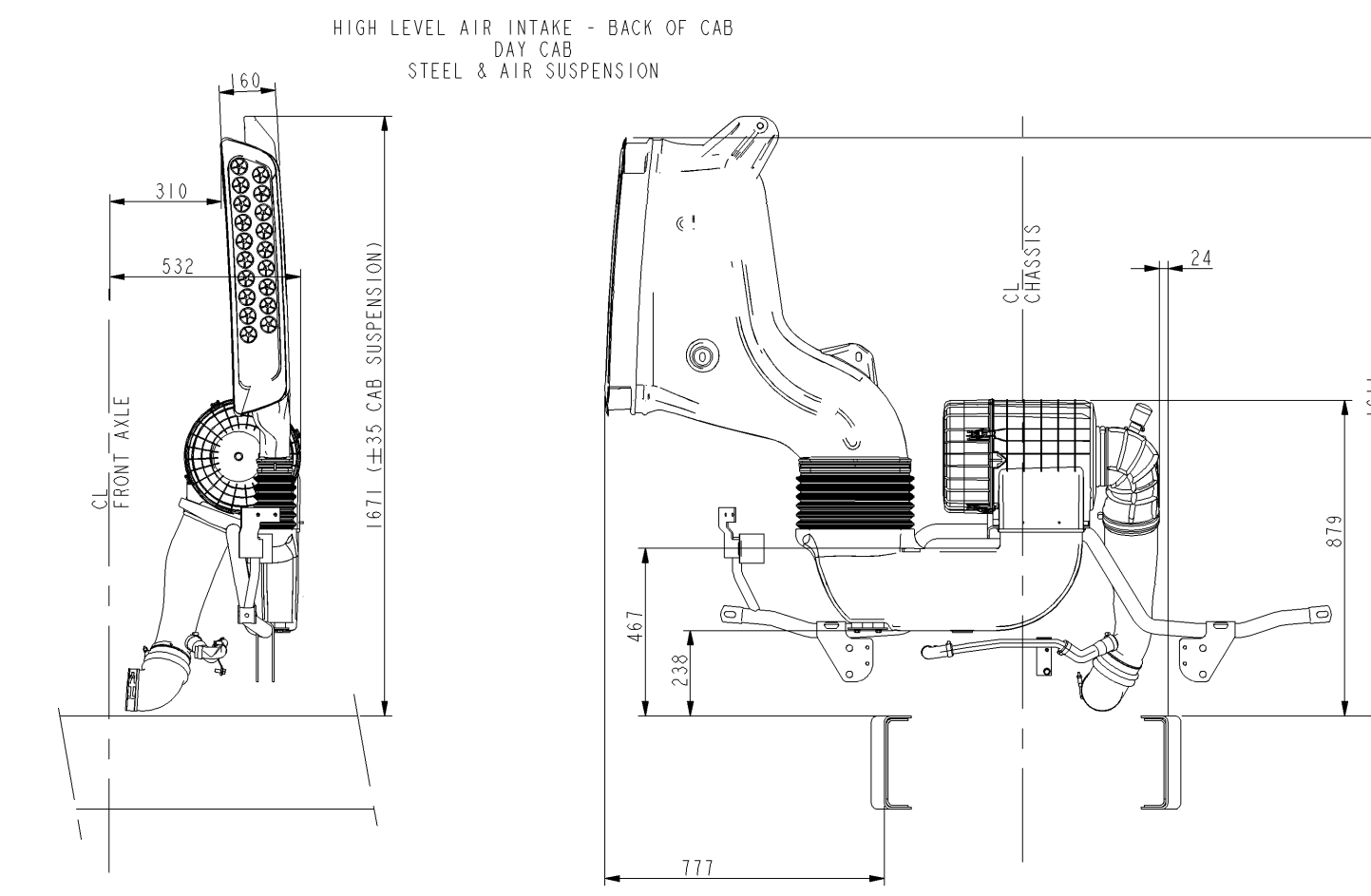
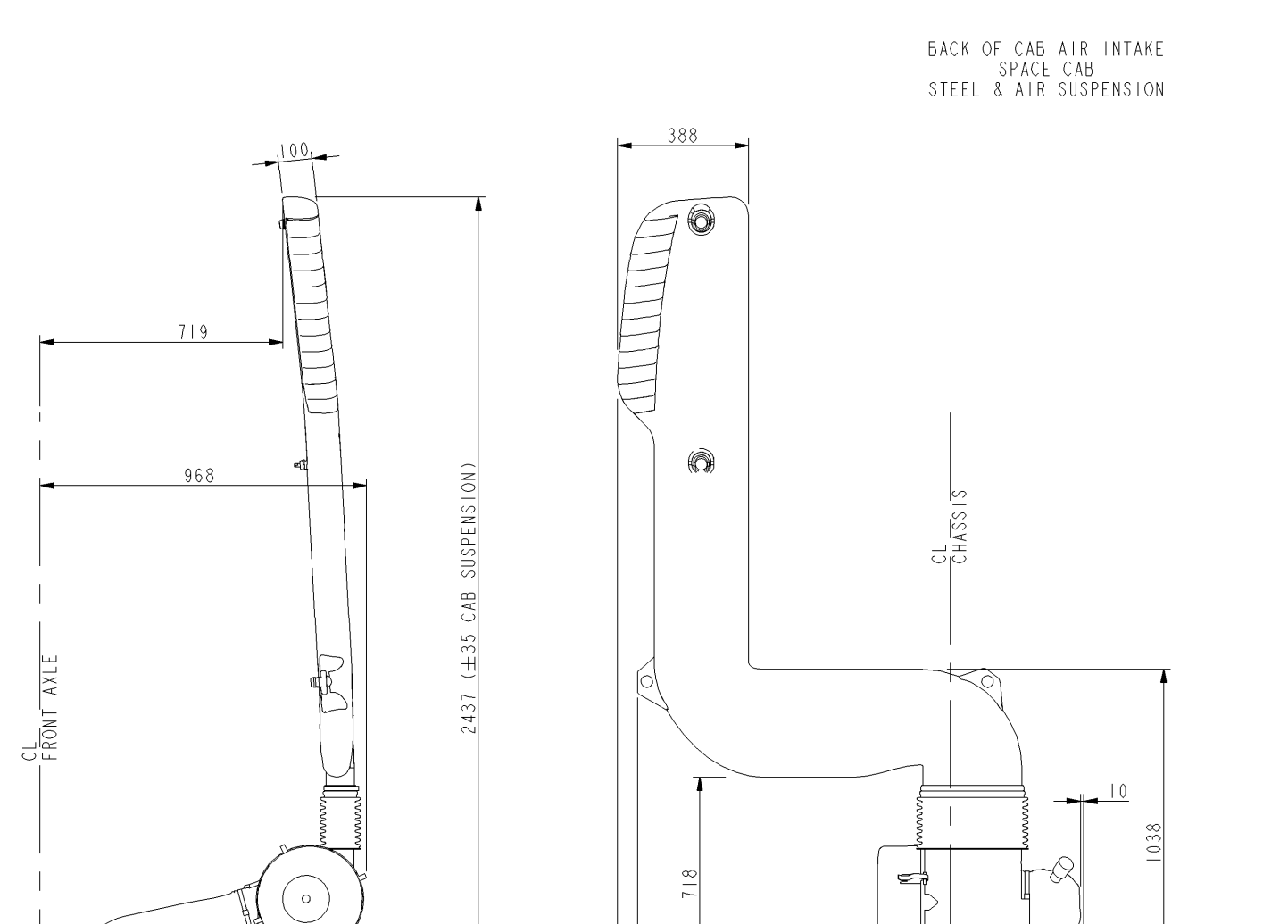
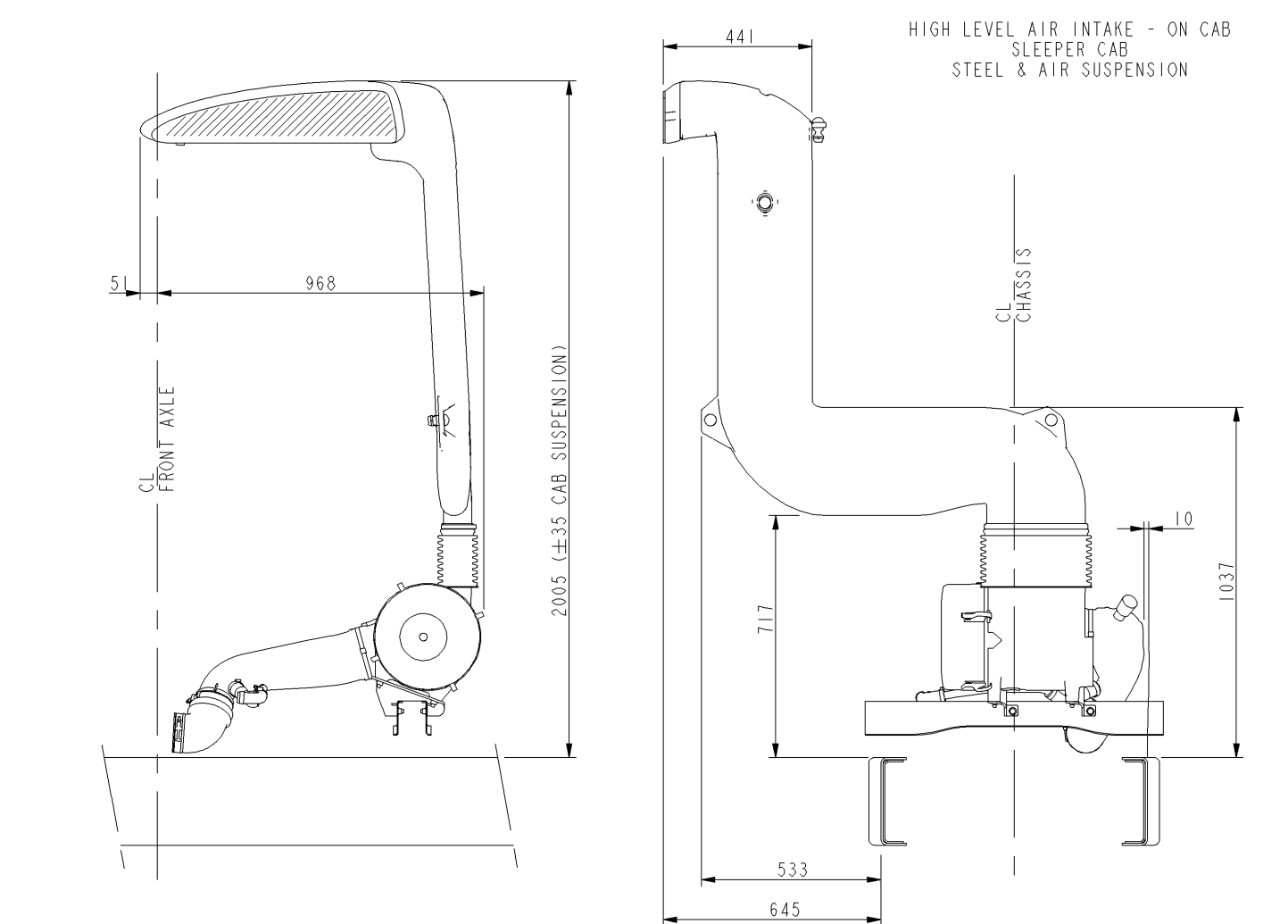
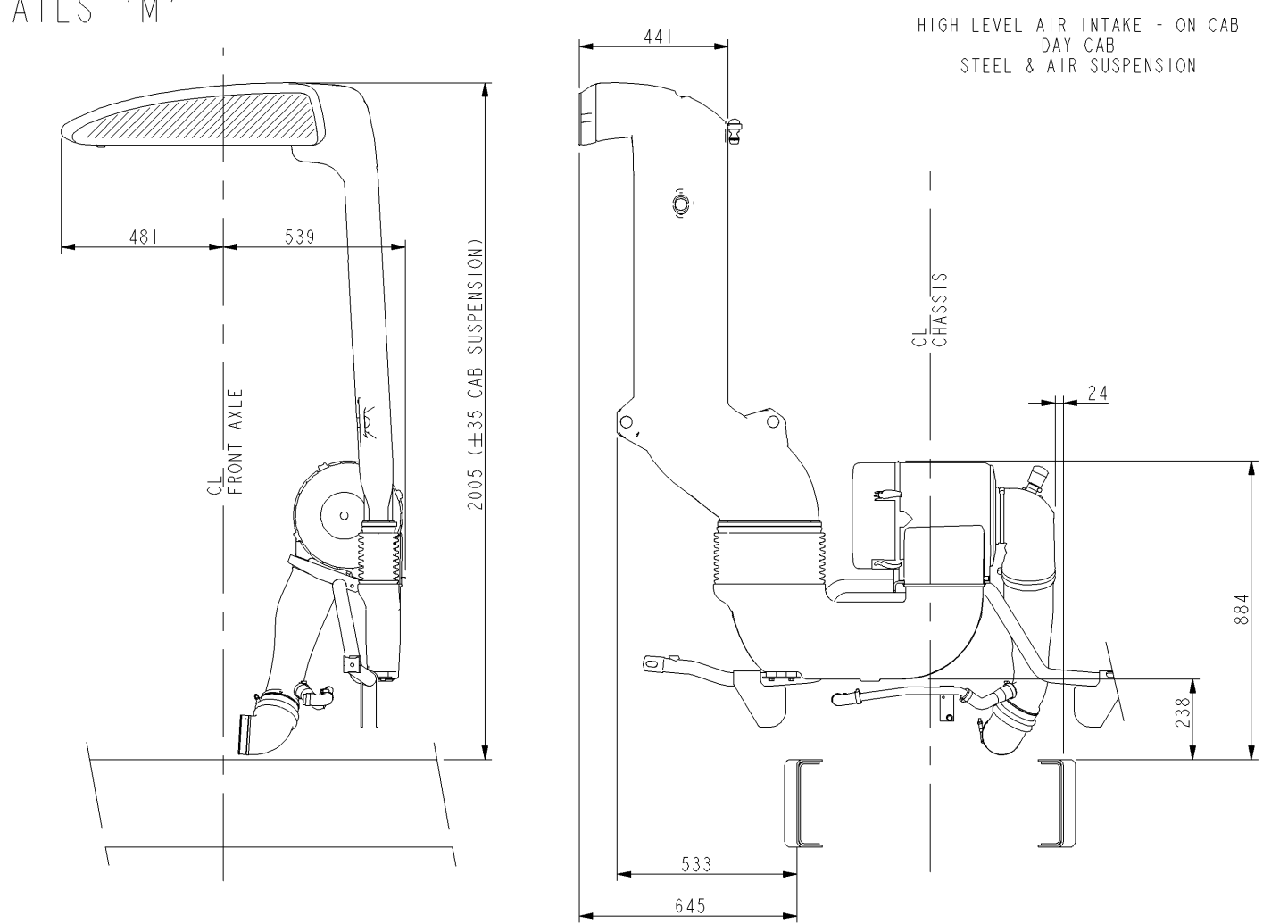

NOTES:

GEEN MATEN VAN TEKENING OPMETEN.
WIJZIGINGEN ZONDER VOORAFGAANDE KENNISGEVING VOORBEHOUDEN.
VOOR UITVOERING VAN HET VOERTUIG RAADPLEG
MEN DE ORDERBEVESTIGING.

DO NOT SCALE DRAWING.
SUBJECT TO MODIFICATION WITHOUT PRIOR NOTICE.
PLEASE SEE NOTE FOR DEFINITIVE VEHICLE LAY-OUT.

NE RIEN RELEVER DU DESSIN.
SUS RESERVE DE MODIFICATIONS SANS AVIS PREALABLE.
VEUILLEZ CONSULTER LE BON DE COMMANDE
POUR LE EQUIPEMENT DU VEHICULE CONCERNE.

KEINE ZEICHNUNGSMASSE AUFMESSEN.
ÄNDERUNGEN OHNE VORANKÜNDIGUNG VORBEHALTEN.
DIE AUSFÜHRUNG DES BETREFFENDEN FAHRZEUGS
ENTNEHME MAN DER AUFTRAGSBESTÄTIGUNG.

In title block Euro 4 is updated to Euro 4/5.		10/03/08	MKJ	BG	5700743	A
modification description		date	drawn by	auth by	mod.no.	issue
general tolerances	tolerance principle	<p align="center">DETAIL - M FA CF 65 Euro 4/5</p>				
for drawing interpretation, see DAF standard:	material					
surfaces/corners	heat/surface treatment	size	scale	sheet	model number	
authorised by	date	paint specification	third angle projection	This drawing is the property of DAF - Trucks N.V. Eindhoven, The Netherlands and may not be copied in whole or in part without the prior written consent of the owner.		
drawn by	date	prod.grp.spec.	spec. indicat.	drawing/issue number		
source	replacement for	replaced by		CAD Pro/ENGINEER		