



Bodybuilder guidelines

DAF LF, CF and XF105

Update: 2010-19



**Bodybuilders' Guidelines is published by
DAF Trucks N.V.**

This information is also available on the internet. The user is responsible for ensuring that he is working with the latest released information. Parts of this publication may be copied or reproduced providing that a reference is made to the source.

In the interest of continuing product development, DAF reserves the right to change specifications or products at any time without prior notice. DAF can in no way be held responsible for any incorrect information included in this manual and/or the consequences thereof.

This publication refers to chassis with FR, GR, PR or MX engine complying to the **Euro 3, Euro 4 and Euro 5 emissions**.

Note

For **Euro 3** chassis with CE, BE, PE or XE engine see the digital publication that is available under file number **BBG0541.zip** on the 'archive' page of the Bodybuilder's info website.

May 2010

GENERAL	1
CHASSIS INFORMATION	2
GENERAL INFORMATION ON SUPERSTRUCTURES	3
SUPERSTRUCTURES	4
CAB INFORMATION	5
PTO AND OTHER ENERGY CONSUMERS	6
ELECTRICAL SYSTEM GENERAL	7
DATA COMMUNICATION SYSTEMS	8
ELECTRICAL SYSTEM LF SERIES	9
ELECTRICAL SYSTEM CF SERIES	10
ELECTRICAL SYSTEM XF SERIES	11
APPLICATION CONNECTOR (CODE) NUMBER LIST	12
PART NUMBERS	13
REACTION FORM	14

GENERAL

	Page	Date
1.1 Purpose	7	201019
1.2 Addresses to contact	7	201019
1.3 Verificaton of superstructure	7	201019
1.4 Statutory requirements	7	201019
1.5 Vehicle specification and layout drawings	8	201019
1.6 Weight distribution	8	201019
1.7 Period of bodying and storage	9	201019
1.8 Painting the chassis and components	9	201019
1.9 DAF vehicle range	9	201019
1.10 Dimensions	12	201019
1.11 Product modifications	12	201019
1.12 Feedback form	12	201019



BODYBUILDERS' GUIDELINES

General

1

1. GENERAL

1.1 PURPOSE

The purpose of these guidelines is to give the bodybuilder advice and assistance to enable him to obtain a homogeneous and optimally functioning assembly of superstructure and DAF chassis.

The manufacturer of the superstructure should make sure that moving parts of the vehicle chassis, in particular the propeller shafts, cannot be restricted in their operation by, for example, parts of the superstructure and/or mountings. All components must remain easily accessible for maintenance and repair! Work on the vehicle should at all times be done by qualified staff.

1.2 ADDRESSES TO CONTACT

In these guidelines the designation "DAF" refers to the responsible subsidiary or importer of DAF Trucks N.V. in the country concerned.

The supplier of the superstructure will under all circumstances remain fully responsible for the product supplied by him and, in view of the safety of the user, he must deliver the product with clear information, instructions for use and/or documentation with respect to the superstructure and any additional equipment. Prior to delivery to the customer, the bodied vehicle should be inspected by the DAF dealer. DAF cannot be held liable for any consequences of the actions of third parties.

1.3 VERIFICATION OF SUPERSTRUCTURE

In view of vehicle safety, product liability and the quality standards set by DAF, it is not permitted to make changes to the design of the vehicle without **prior consultation with and written permission from DAF**.

Machine directives and CE marking

If the superstructure (or parts of it) can be qualified as a machine, special attention should be paid to the machine directive and the CE marking. If necessary, consult the authorities concerned.

Superstructures fitted fully in keeping with these guidelines do not require verification. DAF is always willing to answer any questions in this field.

For the integration of the superstructure with related vehicle systems, see Section 7: "Electrical system general".

Whenever these guidelines are not fully conformed to, and in all cases not provided for in these guidelines, consultation with and verification by DAF is required.

1.4 STATUTORY REQUIREMENTS

Requests for such verifications can be submitted to DAF by sending **in duplicate**, functional description, drawings and engineering calculations of all systems that are affected by the intended modification. If found in order, one set will be returned by DAF with a declaration written down in letter of "**no objection**" (LONO) and possibly accompanied by some comments with regard to the construction to be used.

The superstructure and any vehicle modifications connected with it must in all respects comply with the statutory requirements in the country concerned.

As DAF builds its commercial vehicle chassis fully in accordance with the statutory requirements in force, the responsibility for the **bodied** vehicle rests with the bodybuilder.

The manufacturer of the superstructure should in all cases ensure that the operations carried out on the vehicle fully comply with the applicable quality standards.

When the bodied vehicle is inspected, DAF is not responsible for problems caused by the superstructure or by parts fitted and/or modified by third parties.

BODYBUILDERS' GUIDELINES

General

1.5 VEHICLE SPECIFICATION AND LAYOUT DRAWINGS

1

In determining the right chassis and body specifications, it is essential that the three parties involved, **customer, bodybuilder and DAF**, should each bring in their own specialism. Intensive consultation is the only way to obtain an optimum result. This consultation requires the availability of all Technical data, such as vehicle specifications and layout drawings (DAF bodybuilders' drawings), and the possibility of forming a quick assessment of all the technical possibilities with their specific advantages and disadvantages.

DAF's professional transport advice system, TOPEC, has been developed especially for this purpose and is also available to the bodybuilder. TOPEC enables fast calculation of the effects of particular vehicle dimensions on, for instance, weight distribution, coupling position, turning circle and axle load pattern during unloading. Requests for TOPEC calculations can be submitted to DAF.

Layout drawings

The chassis bodying possibilities can be determined on the basis of the very detailed cab/chassis layout drawings showing many dimensions and component positions. These drawings are available from DAF and they can be found as digital files on the TOPEC CD-ROM and the internet (www.daf.com).

Additionally, DAF can supply on request (chassis number specific) a CAD file in either the 3D-DXF or 3D-STEP 2.14 file format showing the main chassis longitudinal with full hole pattern. Contact DAF for applicable cases with complex superstructures like heavy cranes.

TOPEC availability to the bodybuilding industry

The TOPEC program is available in two versions: 'TOPEC View' and 'TOPEC Light', and can be ordered from DAF via a subscription system.

TOPEC View: A TOPEC View subscription provides a complete digital DAF file of bodybuilders' drawings, recorded on a CD-ROM which is periodically updated. This means that you always have the latest drawings. These drawings can be read and printed using the TIFF viewer that is supplied with the CD-ROM. The CD-ROM also contains the component drawings (cabs, suspension and fuel tanks) and elevations

of chassis and cabs (as shown on the DAF bodybuilders' drawings) in DXF format. This DXF format can be used in your own AutoCAD system or any other program capable of opening a DXF file.

TOPEC Light: On top of the above-mentioned digital file of component and chassis drawings, a TOPEC Light subscription includes the calculation modules required for making layout, weight, turning circle and chassis strength calculations.

1.6 WEIGHT DISTRIBUTION

When constructing the superstructure, make sure that weight is correctly distributed so that the permitted axle loads can be utilised, and take note of the following guidelines:

- The length of the body and consequently the position of the centre of gravity may vary within the axle load distribution tolerance limits permitted in the country concerned.
- To avoid excessive leaning of the vehicle to one side, the difference in weight between the LH and RH wheels on one and the same axle must not be more than 4%; see also the paragraph below on lateral stability.
- The weight under the front axle(s) must in all cases be at least 20% of the total vehicle weight when used solo or in combination with a conventional coupled trailer and at least 30% of the total vehicle weight when used in combination with a mid-axle trailer.
- The weight under the driven axle(s) must be at least 25% of the maximum total weight of the vehicle or vehicle combination.
- The centre of gravity of the total of superstructure, any loading/unloading equipment and vehicle load must at all times be within the theoretical wheelbase, because otherwise vehicle behaviour could be adversely affected.

Chassis reinforcements and additional components, such as compressors, additional fuel tanks and loading and unloading equipment, affect the weight and therefore the weight distribution of the vehicle being bodied. It is therefore essential that the vehicle, including any extra equipment, should be weighed before the bodying is started. Only then will it be possible to establish in time the effect any such extra equipment may have on the location of the vehicle's centre of gravity.

Lateral stability (dynamic)

High superstructures, whether or not in combination with a high centre of gravity of the load, are sensitive to side winds and may have an adverse effect on the lateral stability and therefore the driving characteristics of the vehicle. The same applies in the case of:

- asymmetric loading;
- specific load distribution;
- axle load shifts when the vehicle is partly laden;
- axle load shifts when the load is moving.

In all cases, ultimate responsibility rests with the supplier of the superstructure or the user of the vehicle.

1.7 PERIOD OF BODYING AND STORAGE

When a vehicle, for instance, because of a long period of bodying, is not being used for a prolonged time, measures should be taken to guarantee the continued high quality of the vehicle. These measures depend on the estimated duration of storage and/or bodying.

The measures that should normally be taken, may include the following:

- Closing windows and roof hatch.
- Checking fluid levels and, where necessary, topping-up reservoirs.
- Checking the tyre pressure.
- Removing, storing and charging the batteries.
- Checking the coolant antifreeze content.
- Patching up damaged spots in paintwork.

For measures to be taken in the event of very long storage periods, DAF should be contacted.

1.8 PAINTING THE CHASSIS AND COMPONENTS

In case the chassis (cab) and components must be (re)ainted then the under mentioned area's must thoroughly be masked before painting to avoid problems with electrical or mechanical vehicle systems.

- The contact area's between wheel hub and wheel rim and flanged nuts.
- Brake disks, brake calliper and pads.

- Breather valves placed on components, such as differential, EAS unit, ECAS valves, brake valves and so on.
- Air intake openings on filter units.
- NOx sensors and solenoid valves.
- Heat shield panels and heat isolated exhaust pipes (when fitted).
- Sealings and sliding joints on propeller shaft.
- Identification plates (on gearbox, drive axle and valves etc.).
- Door locks.
- Cab windows, head - brake - indicator lights and reflectors.



NOTE: Many components and in particular cab panels are produced in a variety of material types each requiring a different specific (re)paint treatment. For obtaining the cleaning and (re)spraying guidelines (preparations), as published by the DAF After Sales/ Service department, please contact a DAF representative in your country. For applying the top coating always follow the manufacturer's instructions.

1.9 DAF VEHICLE RANGE

DAF's vehicle range is composed of several tractor chassis in the weight category above 12 tonnes and an even wider variety of rigids in the category of 6 tonnes GVW and over.



20090503-035

BODYBUILDERS' GUIDELINES

General

1

DAF LF45 series

This series offers gross vehicle weights from 7,5 to 12 tonnes. The trucks are intended for intensive use in urban and regional distribution transport and are powered by **4.5 litre four-cylinder FR diesel engines** generating outputs from 103 kW up to 152 kW, or by **6.7 litre six-cylinder GR diesel engines** with a power rating of 165 kW up to 184 kW.

DAF LF55 series

This vehicle series, with gross vehicle weights from 12 to 19 tonnes, is intended for light to medium-weight transport in urban and regional goods distribution. These vehicles are also excellently suited for a wide range of applications in the field of public utility services. This series is equipped with **4.5 litre four-cylinder FR diesel engine** generating an output of 136 up to 152 kW or by **6.7 litre six-cylinder GR diesel engines** offering outputs from 165 kW up to 220 kW

DAF CF series



G000540

DAF CF65 series

The DAF CF65 series underlines the importance of market segmentation and of medium line vehicles with specific features and characteristics for a huge diversity of applications, body types and operational conditions. The DAF CF65 series has been developed as a two-axle rigid for local and regional goods distribution and special transport applications, such as council cleaning services and fire services. With a maximum GVW of 19 tonnes, this series is powered by **6.7 litre GR diesel engines** generating outputs from 165 kW up to 220 kW.

DAF CF75 series

The DAF CF75 series is a real all-rounder with a choice of chiefly two-axle and three-axle models. These vehicles are excellently suited for medium-weight to heavy regional and national distribution transport and for a wide range of applications in the field of public utility services, such as council cleaning services. The **9.2 litre PR diesel engines** use a highly advanced combustion principle and they have four valves per cylinder. With power outputs from 183 kW up to 265 kW, they are suitable for gross combination weights up to 40 tonnes.

DAF CF85 series

The DAF CF85 vehicles are equipped with **12.9 litre MX diesel engines**, which use a highly advanced combustion principle and have four valves per cylinder. With engine outputs from 265 kW up to 375 kW, this truck is made for heavy work. It can be specified as a two-axle, three-axle or four-axle vehicle with one or two driven axles. A robust truck for intensive medium-range transport requiring high gross combination weights (over 40 tonnes), for transport in the building industry and/or heavy special transport.

DAF XF series



G000392

XF105 series

The DAF XF is the flagship of the DAF range. With the XF105 series, DAF has again moved a step forward in the ever continuing development of vehicle and engine technology. The XF chassis is fitted with **12,9 litre MX diesel engines**, which use a highly advanced combustion principle and have four valves per cylinder. With engine outputs from 300 kW up to 375 kW, these vehicles are ideal for long-distance (international) haulage requiring gross combination weights of 40 tonnes.

With the Super Space Cab, the driver virtually has a mobile residence, complete with all the conveniences required for lengthy journeys (away from home for on average 1 to 3 weeks). The DAF XF series makes no concessions. It combines a very high level of driver comfort with optimum transport performance and the lowest possible costs of ownership for the transport operator.

1

Designation	Type	Sort of chassis	DAF-series					
			LF45	LF55	CF65	CF75	CF85	XF105
FA	4x2	Truck chassis	■	■	■	■	■	■
FAR	6x2	Truck chassis with single-wheel trailing axle				■	■	■
FAS	6x2	Truck chassis with twin-wheel trailing axle				■	■	■
FAN	6x2	Truck chassis with rear steered axle		■		■	■	■
FAG	6x2	Truck chassis with second steered axle				■	■	
FAT	6x4	Truck chassis with double-drive tandem axle				■	■	■
FAC	8x2	Truck chassis with 2 front axles, single drive axle and twin-wheel trailing axle					■	
FAX	8x2	Truck chassis with 2 front axles, single drive axle and rear steered single-wheel trailing axle					■	
FAK	8x2	Truck chassis with three rear axles, including twin-wheel trailing axle					■	■
FAD	8x4	Truck chassis with 2 front axles and double-drive tandem axle				■	■	■
FT	4x2	Tractor chassis		■		■	■	■
FTR	6x2	Tractor chassis with single-wheel trailing axle					■	■
FTS	6x2	Tractor chassis with twin-wheel trailing axle					■	■
FTG	6x2	Tractor chassis with second steered axle					■	■
FTP	6x2	Tractor chassis with non-steered second axle					■	■
FTT	6x4	Tractor chassis with double-drive tandem axle					■	■
FTM	8x4	Tractor chassis with three rear axles; a steered axle in front of a double-drive tandem axle						■

BODYBUILDERS' GUIDELINES

General

1

Wheelbase and rear overhang indications

The indications for wheelbase and rear overhang (WB/AE) used in these bodybuilders' guidelines and in general at DAF can be found for each vehicle type in the following survey:

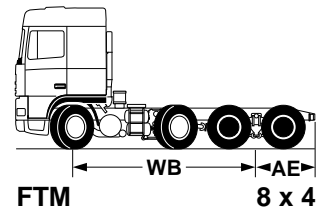
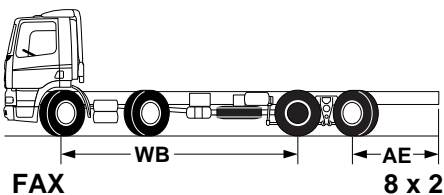
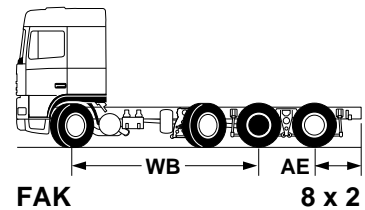
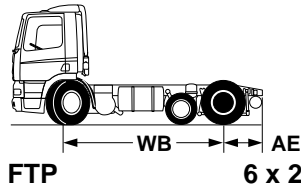
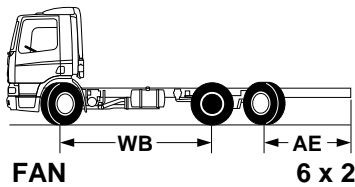
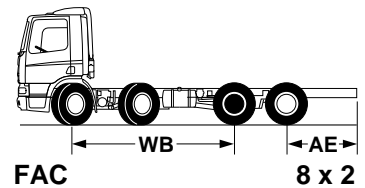
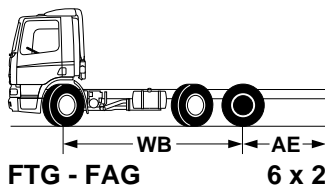
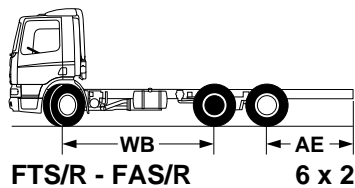
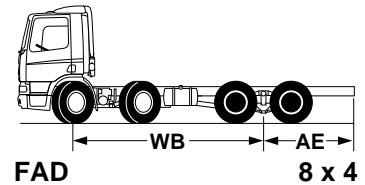
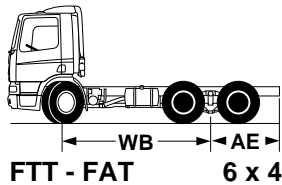
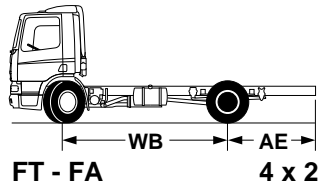

G000307

1.10 DIMENSIONS

All dimensions in these bodybuilders' guidelines are shown in millimetres, unless stated otherwise.

1.11 PRODUCT MODIFICATIONS

In the interest of continuing product development, DAF reserves the right to make changes in the specifications or the designs of the vehicles without prior notice.

Furthermore, vehicle specifications may vary from country to country, depending on local conditions and legislation. For exact and up-to-date information, please contact the local DAF sales organisation.

1.12 FEEDBACK FORM

In view of the importance of maintaining the present level of quality and user-friendliness of the DAF Bodybuilders' Guidelines, your recommendations and/or suggestions will be highly appreciated.

Use the : "Feedback form" you will find on the last page(s) to communicate your findings to us.

CHASSIS INFORMATION

	Page	Date
2.1 Levelling the chassis	15	201019
2.2 Drilling of holes	15	201019
2.3 Welding on the chassis	16	201019
2.4 Modifying the rear overhang	17	201019
2.5 Wheelbase modifications	20	201019
2.6 Attachment of components to the chassis	21	201019
2.7 Replacing rivets by bolts	22	201019
2.8 Inlet and exhaust systems	23	201019
2.9 Fuel system	24	201019
2.10 Chassis and cabine related dimensions	25	201019
2.11 Drawbar cross member	30	201019
2.12 Rear light brackets	36	201019
2.13 Wheel mounting	36	201019
2.14 Wheel clearance	37	201019
2.15 Location of the mudguards	40	201019
2.16 EC-approved rear underrun protection	41	201019
2.17 Automatic lubrication	42	201019

BODYBUILDERS' GUIDELINES

Chassis Information

2

2. CHASSIS INFORMATION

2.1 LEVELLING THE CHASSIS

It is essential for the quality and durability of the bodied vehicle that the chassis should be in a completely level position when it is being bodied. The side members should be parallel and the chassis frame must not be twisted.

For the levelling of an air-suspended chassis, at least three adjustable supports must be used. These supports must not be removed during the bodying of the vehicle.

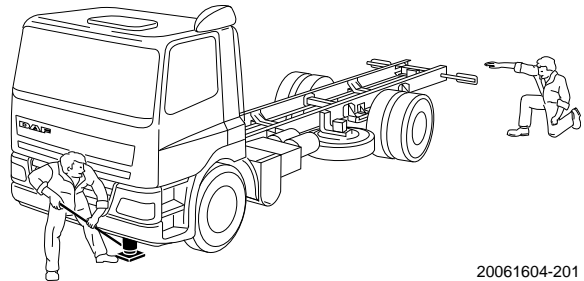

20061604-201



WARNING! Each time the vehicle is moved, the chassis must be levelled again!

2.2 DRILLING OF HOLES

When mounting components, use the existing holes in the chassis whenever possible, preferably the holes according to **BAM 1 and 3** (see section: 3.2: "BAM's - body attachment methods"), which are factory-made and exclusively intended for the superstructure. The location of these holes is therefore indicated on the bodybuilders' drawings.

Adhere to the following instructions when drilling holes:

- NEVER drill holes in the flanges of the side members.
- NEVER drill holes in the tapered ends of a tractor chassis frame.
- NEVER weld filler pieces into any unused holes of the chassis frame.
- To prevent the forming of cracks from the drilled holes, these holes must always be deburred - by 45° countersinking (on two sides!) - and subsequently treated with primer/paint.
- The drilling of holes less than 70 mm away from a bend in the chassis frame is not permitted.
- A hole drilled by mistake close to the radii of (or within) the tapered section of the chassis must always be protected against fatigue cracks at its edges by fitment of the largest (and accordingly tightened) flange bolt and nut possible.

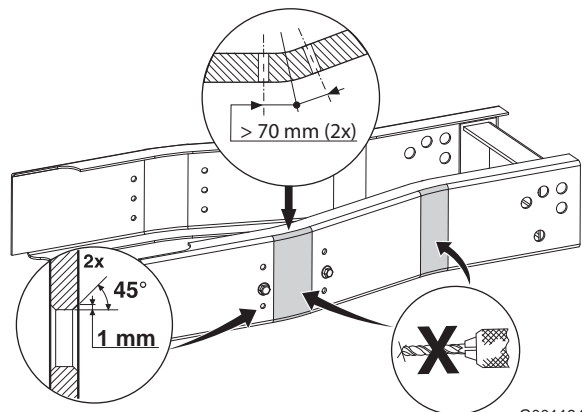

G001184

BODYBUILDERS' GUIDELINES

Chassis Information

Dimensions for holes drilled in side members:

- B > 3 x D (D = diameter of largest hole, at most 18 mm)
- C > 70 mm (tractor chassis), 50 mm (truck chassis)

For deviations from the above-mentioned dimensions, DAF should be consulted.

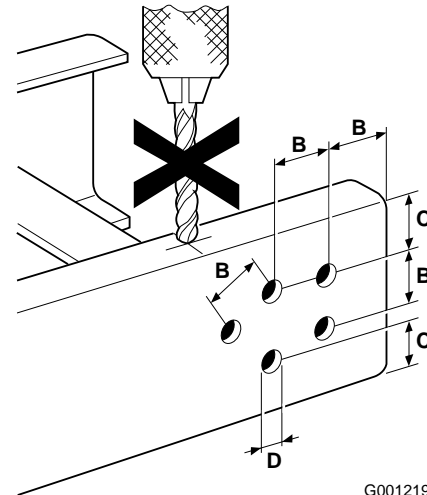

Minimum distances for drilling of holes

2

2.3 WELDING ON THE CHASSIS



WARNING! *Welding on the chassis is not permitted without a written permission from DAF, with the exception of welding operations required for rear overhang extensions.*

The following **DAF welding instructions** should be observed at all times:

Welding on the chassis

- Disconnect the connectors of electrical and electronic equipment (sensors and actuators) and the battery terminals if they are less than 1 metre away from the chassis part to be welded or the earth terminal of the welding equipment.
- If the battery terminals have to be disconnected, all electronic units mounted on the chassis and the bulkhead lead-through connectors should be disconnected, too.

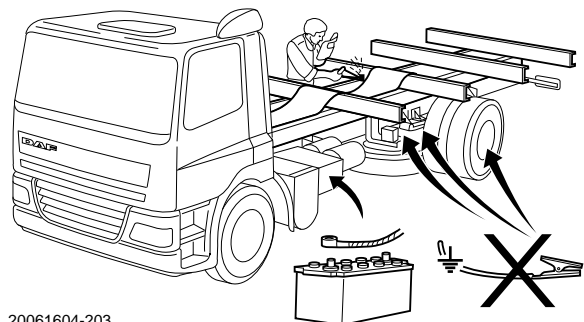

Measures to be taken when welding!

Welding on the cab

- Always disconnect the batteries (starting with the negative lead).
- Disconnect the connectors between chassis and cab (bulkhead lead-through).
- Disconnect the connectors of electrical and electronic equipment if they are less than 50 cm away from the cab part to be welded or the earth terminal of the welding equipment.

Welding on the superstructure

- Adhere to the above instructions for 'welding on the chassis', supplemented by specific bodybuilders' instructions.

General

- The earth terminal should never be attached to vehicle components such as engine, axles and springs. Arcing on these parts is not permitted either, because of the risk of damage to bearings, springs, etc.
- The earth terminal must make good contact and be placed as close as possible to the part to be welded.
- Plastic pipes, rubber parts and parabolic springs should be well protected against welding spatter and temperatures higher than 70°.
- The contact switch must not be in the accessory or contact position. The contact key should be removed.
- Reconnect in reversed order of disconnecting. Ensure that a good earth connection is made between chassis, engine and cab.



WARNING! If the connectors are not disconnected, serious damage may be caused to the electronic control units (ECU's) of various vehicle systems.

See section: 7.13: "Connection points and permitted power loads" for the connection points on LF, CF and XF vehicles.

2.4 MODIFYING THE REAR OVERHANG

For the chassis material to be used for rear overhang extensions (if they are necessary), see section 13: "Part numbers".

Extending/shortening the rear overhang

When extending the rear overhang, take note of the following:

- The maximum rear overhang (AE) extension is 500 mm, provided that the maximum rear overhang (AE) length of 60% of the wheelbase (WB) is not exceeded.
- The rearmost cross member must be retained when the chassis frame is made longer or shorter.

BODYBUILDERS' GUIDELINES

Chassis Information

- When the rear overhang is shortened, at least 30 mm must be left behind the rear spring brackets (leaf-sprung chassis) or the stabiliser bracket (air-sprung chassis).
- The distances between the cross members in the chassis frame should be not more than 1200 mm.

2



WARNING! The rear overhang of tractor chassis and of vehicles with side members of KF 600 material must NOT be changed

Tapering of chassis side member rear ends

On vehicles used for (high-)volume transport (lower position of drawbar cross member) and/or equipped with under-chassis tail lifts, the rear ends of the side members may be tapered in accordance with the dimensions shown in the opposite drawing.

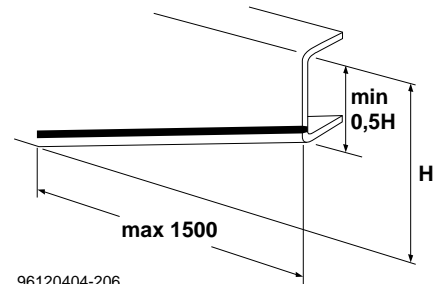

For certain applications, for instance for plant bodies, it is permitted to make a bend in the rear overhang. To do this, remove a sector from the side member, starting from the underside and ensuring that the upper flange is left intact and that, after the bending of the chassis, both the web and the lower flange can be welded together again. See the opposite drawing.

When doing this, the welding instructions must always be adhered to.

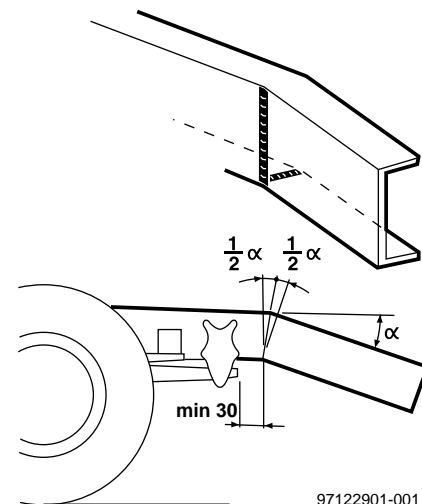

Welding instructions for rear overhang extensions

The weld should always comply with (European) quality standard EN25817, quality class B.

Main chassis profile A

1. Bevel off the parts to be welded at an angle of 45°. Put them against each other.
2. Make a provisional weld by tack welding (using an electrode with a diameter of 2.5 mm).
3. Fill the joint (using an electrode with a diameter of 3.5 mm).
4. Grind down the outside weld area as far as the weld.
5. Fill the joint from the outside (using an electrode with a diameter of 2.5 mm or 3.5 mm).
6. Grind the outside and inside surfaces until they are smooth.

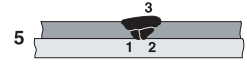
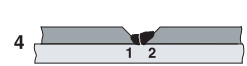
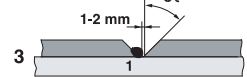
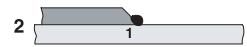
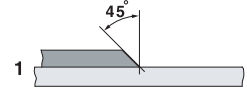
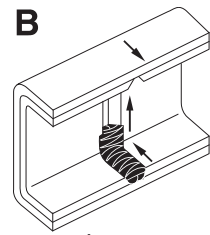
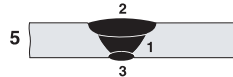
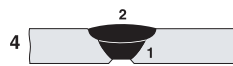
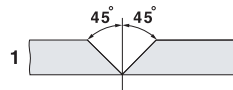
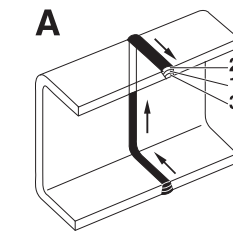

G000560

Inner reinforcement profile B

1. Bevel off the inner profile to be welded at an angle of 45°. (Do not grind the main chassis profile).
2. Make the first weld (using an electrode with a diameter of 2.5 mm).
3. Bevel off the inner profile and positioned it approximately 1 to 2 mm from the first weld (using an electrode with a diameter of 3.5 mm).
4. Make the second weld (using an electrode with a diameter of 2.5 mm).
5. Fill the weld to the top (using an electrode with a diameter of 3.5 mm).
6. Grind the inside surface of the reinforcement profile until it is smooth.



NOTE: At stage 2 and 4 the first and second weld seam will join together the main chassis and inner reinforcement profile.

The drawing shows how a weld should be made with a welding electrode or a wire electrode (MAG).

BODYBUILDERS' GUIDELINES

Chassis Information

Position of the welds between main and reinforcement profile

Independent from whatever welding process is chosen, distance (A) between the separate welds must be at least 100 mm to avoid unacceptable stress concentration. It is advised to round of the edges over 50 mm to each side of the weld to diminish the possibility of notching.

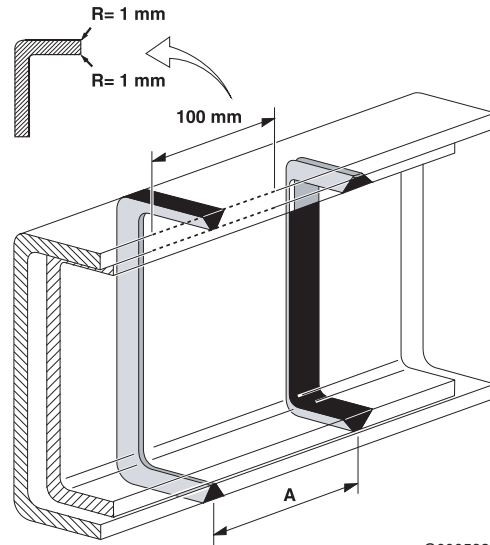

G000562

Specification of welding material

WELDING ELECTRODE

The **welding electrode** should meet one of the undermentioned specifications or should be of equivalent quality.

LF series CF65	EN757	EY 4666 MN B
CF75 and CF85 Series XF series	AWS5.1 ISO 2560 DIN 1913 BS 639	E7016 - 1 E 515 B 24(H) E 5155 B 10 E 5154 B 24(H)

WIRE ELECTRODE

The wire electrode should meet one of the undermentioned specifications or should be of equivalent quality.

G 35 2 G2Si or G38 3 G3Si1 EN 440: 1994
Wire diameter: 0.8 mm
Welding current: 120 A
Voltage: 17 - 18 V
Gas mix: 80% Ar and 20% CO₂

2.5 WHEELBASE MODIFICATIONS

Wheelbase modifications may only be carried out with DAF's prior permission in writing and in accordance with DAF's instructions. The written permission and the conditions to which it is subject, should at all times be kept with the vehicle documents.



WARNING! The wheelbase of a tractor chassis and of vehicles with side members of KF 600 material must NOT be changed!

2.6 ATTACHMENT OF COMPONENTS TO THE CHASSIS

Components such as toolboxes, extra fuel tanks, onboard weighing system, compressors and side underrun protection, will usually be attached to the side of the chassis. For all loaded connections with the chassis, 10.9 flange bolts or bolts of the same property class, combined with washers, must be used. The hardness of the washers should be at least 265-320 HB. Furthermore, the contact surfaces of bolted connections should be provided with a thin coat of primer (thickness 17 - 25 µm) and they should be free from paint and other impurities. The first service inspection of the vehicle must include the retorquing of all superstructure attachment bolts.

If required, for the tightening torques of components such as steering gear, mounting frame of the Euro 4 and 5 exhaust system, axle suspension system, cab mounting, etc., see the workshop manual.

Tightening torques for DAF flange bolts ⁽¹⁾			
Bolt type	Torque in [Nm] ⁽²⁾ for property class:		
	8.8 class B	10.9 class B	12.9 class B
Plain flange bolts; standard pitch			
M 8x1,25	21	30	
M10x1,5	42	60	
M12x1,25	-	110	
M12x1,75	73	110	
M14x1,50	-	170	
M14x2	116	170	
M16x1,50	-	260	
M16x2	180	260	
M18x1,5 / M18x2,5	-	360	
M20x1,5 / M20x2,5	-	520	
M22x1,5 / M22x2,5	-	700	
Clamping flange bolts ⁽³⁾			
M14			275
M16			425
M18			550

(1) If non-DAF bolts are used, adhere to the supplier/manufacturer's instructions.

(2) These tightening torques apply to new wax-dipped or oil-dipped bolts from DAF. The tightening torque tolerance is 16%.

(3) Clamping bolts are no longer used by DAF.

BODYBUILDERS' GUIDELINES

Chassis Information

Depending on the total weight (G) and the centre of gravity of the component in relation to the side member (a) to which the component is to be attached, one of the solutions shown here may be chosen.



NOTE:

- If the load moment on a component carrier is higher than 350 Nm on a chassis frame **without** flitches or if it is higher than 500 Nm on a chassis frame **with** flitches, a cross connection* between the two side members must be made. This cross connection should preferably be a bolted connection with silentbloc (with a minimum rigidity of 20 kN/mm) for the absorption of forces and vibrations.
- An extra cross connection is not required if it would coincide with an existing cross member in the chassis frame.
- When components are relocated, the bolts used must always have the same property class as those used for the original fitting. The length of the bolt should be increased by the thickness of the material of the component carrier.

* For part numbers, see section 13.1: "Mountings" .

Please take care of the required fitting of side underrun protection.

Ground clearance

If components are attached to the chassis, whether they are re-located existing components or new ones which are being added, it should be ensured that there will be sufficient ground clearance **in any circumstances**.

The minimum ground clearance under normal operating conditions is **80 mm** with the chassis suspension bottoming (metal to metal), or **170 mm** with the chassis in driving position (laden).

2.7 REPLACING RIVETS BY BOLTS

If, for whatever reason, rivets have to be removed, they may be replaced by bolts or 'Huckbolts'.

$$\frac{a \text{ (mm)} \times G \text{ (N)}}{1000} \leq 350 \text{ Nm}$$

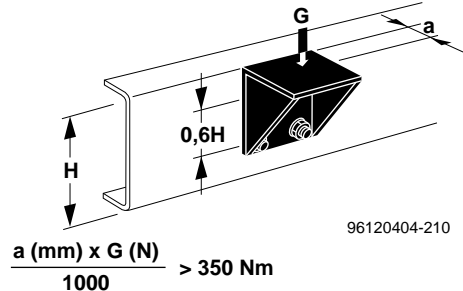
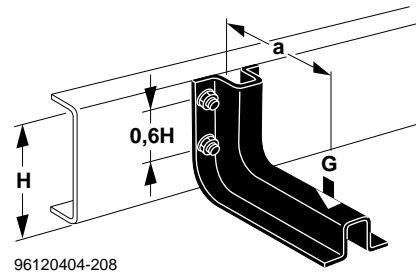

$$\frac{a \text{ (mm)} \times G \text{ (N)}}{1000} > 350 \text{ Nm}$$

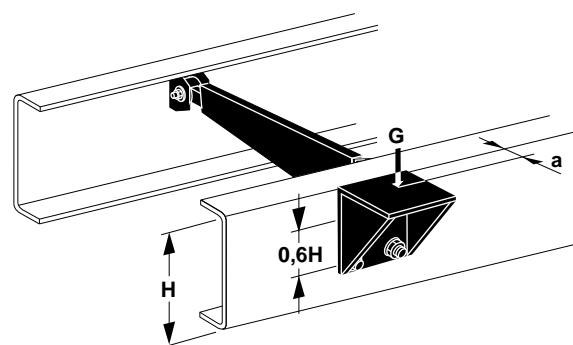
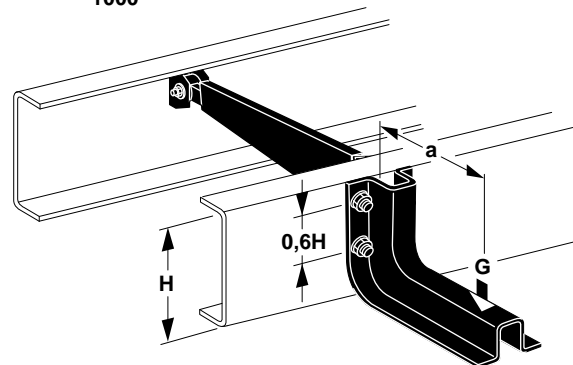

The diameter of the hole of the removed rivet is 13 mm. There are three replacement options:

- Fitting an M14 - 8.8 flange bolt in hole reamed to a diameter of 14H7.
Attention: an unthreaded shank section with length L is required, see illustration.
- Fitting an M16 - 10.9 flange bolt in hole with a diameter of 17 mm.
- Fitting an HP8 - 5/8" Huckbolt.

For the tightening torques of DAF flange bolts, see the table concerned in section 2.6: "Attachment of components to the chassis".

$$t_1 + t_2 > L > t_1 + 0,5 \times t_2$$

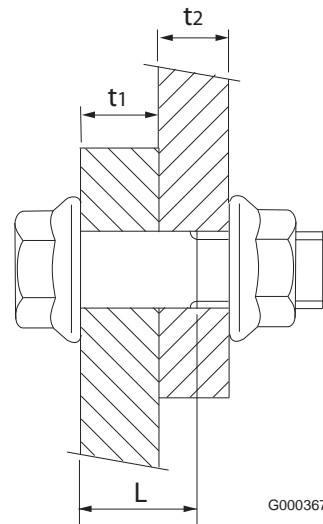

2.8 INLET AND EXHAUST SYSTEMS

When modifications are made to the engine **air inlet system**, verification by DAF is in any case required, in view of type approval and the possible effect on engine performance and /or fuel consumption. At all time the intake manifold opening of the standard or eventual modified air inlet system must be kept clear of body panels or brackets of any kind for at least 70 mm to avoid obstruction of the air flow and possible negative effect on the engine performance.

If modifications are made to the **exhaust system**, consultation with DAF is required, in view of type approval and possible effect on engine performance and /or fuel consumption.

Other matters to which attention should be paid in relation with the exhaust system are the following:

- Take care that no flammable materials are fitted near the exhaust system. As plastic materials must not be exposed to temperatures higher than 70°C, they should be protected with heat shields.

BODYBUILDERS' GUIDELINES

Chassis Information

2

- There must be a minimum clearance of at least 50 mm between the exhaust silencer/ exhaust pipes and the following component, rear wall cab, gearbox and brake system components.
- The complete exhaust system of Euro 4 and 5 vehicles consists of the following components; a silencer, an AdBlue tank, an AdBlue pump module and an AdBlue dosing module. Relocation of the complete exhaust system or parts of it is only possible after consultation with DAF.

2.9 FUEL SYSTEM

Without DAF's prior permission in writing, no modifications may be made to the fuel system. However, fitting an extra fuel tank is permitted. Any fuel tanks used must be DAF fuel tanks.

There are three ways of connecting an extra fuel tank:

1. Single or double suction with a through-connection.
2. Double suction with a switching valve (see figure).
3. Double suction with tee piece (only for tanks of the same size; consult DAF).

Notes on method 1:

The filler openings of the two tanks must be at the same level. Avoid the use of tanks of different height, to ensure correct indication of the fuel level. Apart from this, the advantage of the extra fuel storage capacity could even be (partly) undone when tanks of different height are fitted. All DAF fuel tanks are provided with an M22 threaded hole for the fuel drain plug and they are not suitable for bottom to bottom connection. DAF fuel tanks equipped with a low positioned opening (internal \varnothing 30 mm) to support the described bottom to bottom connection are only available as a service component. To avoid differences in air pressure (= differences in fuel level) between the two tanks, an (\varnothing 8 mm) air pipe must be fitted between the return pipes of the two floats that are intended for extra fuel consumers.

When extra fuel consumers have to be connected, the tank can be provided with extra suction and return pipes on the existing fuel tank float. These connections are as standard provided with sealing plugs held in place by a holding cover. By removing this cover, these plugs can also be removed and replaced by quick-release couplings for an 8 mm fuel pipe. Also see the opposite drawing.

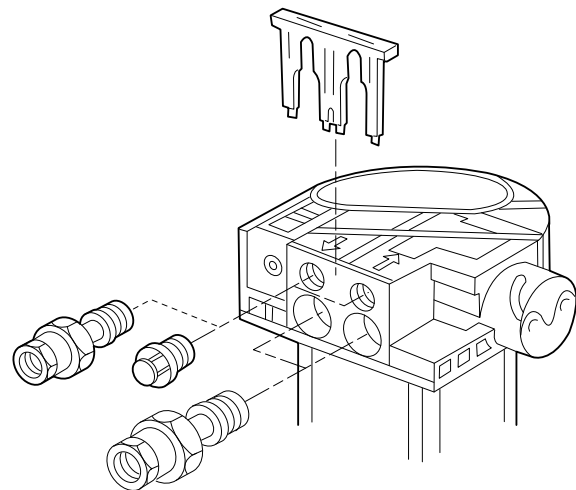
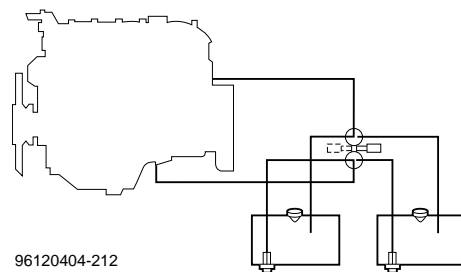

For the part numbers, see section 13: "Part numbers".

2.10 CHASSIS AND CABINE RELATED DIMENSIONS

For details of the chassis (including flich positions) and the location of the components, see the bodybuilders' drawing of the vehicle concerned. These drawings can be obtained from DAF and are available on the internet (www.daf.com). To **TOPEC** subscribers they are available as digital files on CD-ROM (see section 1.5: "Vehicle specification and layout drawings").

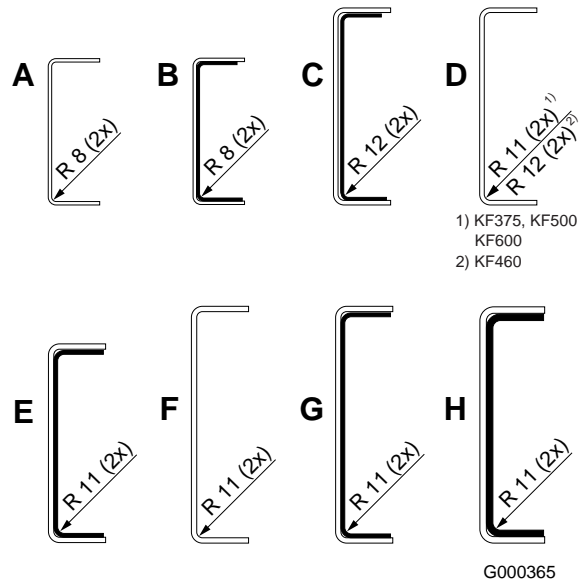

BODYBUILDERS' GUIDELINES

Chassis Information

Chassis specification: Tractors and Rigid

Vehicle type ^{(1) (4)}	Side member dimensions [mm]	Chassis section	Flitch dimensions [mm]	Chassis section	Wx _{chassis} ⁽²⁾ [cm ³]		Material, σ_v ⁽³⁾ [N/mm ²]
					[-----]	[[-----]]	
FT (LF55)	260x75x6	D	-	-	322	-	460
FT	260x75x6	D	+ 245x65x5	E	322	524	600
	260x75x7	D	+ 245x65x5	E	368	584	500
FTG	260x75x7	D	+ 245x65x5	E	368	584	500
FTP	260x75x6	D	-	-	322	-	600
FTR	260x75x7	D	+ 245x65x5	E	368	584	500
FTS	310x75x7	F	+ 295x65x5	G	476	766	375
FTT							
FTM	310x75x8,5	-	+ 292x65x8,5	H	-	1004	375
FA (LF45)	192x66.5x4.5	D	+ 180x47/62x4	B	148	238	460
FA (LF55)	260x75x6	D	+ 245x60x5	C	322	524	460
FA/N FAR/S	260x75x7	F	+ 245x65x5	E	368	584	375
	310x75x7	D	+ 295x65x5	G	476	766	375
FAN (LF55)	260x75x6	D	+ 245x60x5	C	322	524	460 ⁽⁵⁾
FAT	260x75x7	D	+ 245x65x5	E	368	584	500
	260x75x7 ⁽⁶⁾	D	+ 245x65x5	E	368	584	375
	310x75x6	F	+ 295x65x5	G	417	696	600
	310x75x7	F	+ 295x65x5	G	476	766	375
	310x75x8.5	-	+ 292x65x8.5	H	-	1004	375
FAX	310x75x7	F	-	-	-	696	375
	310x75x8.5	-	+ 292x65x8.5	H	-	1004	375
FAD	310x75x6	F	+ 295x65x5	G	417	696	600
	310x75x7	F	+ 295x65x5	G	476	766	375
	310x75x8.5	-	+ 292x65x8.5	H	-	1004	375
FAK/G	310x75x7	F	+ 295x65x5	G	476	696	375

(1) Always refer to the vehicle specification and/or the bodybuilder drawings which are available from DAF. On the chassis overview and specifications no rights to delivery can be derived.

(2) Resistance moment Wx [cm³] of the chassis against bending (caution: indicated values apply to 2 side members).

(3) Chassis material: minimum yield point 0,2% [N/mm²]. Permissible load 0,4x (dynamic).

(4) Chassis types with 192x66.5x4.5 or 260x75x6(7) mm frame and **continuous** inner reinforcement flitches (full chassis length) - which also includes the (G)V chassis - require the added strength and/or rigidity of a sub-frame/superstructure construction (also see the text on chassis design and section 4).

(5) Material according standard: BSEN 10149-2:1996:S460MC.

(6) FAT chassis with 600 cm wheelbase i.c.w. 325 or 360 cm rear overhang (AE).

Chassis specification: Main dimensions

Vehicle type ⁽¹⁾	A	B	RBV	RBA
LF45 series	-	-	859	859
LF55 series 12-15 tonnes	693	284	862	790
LF55 series 18-19 tonnes CF65 series	643	284	862	790
CF75-85 series	1100	800	930	790
FAD CF75-85 FAC/X CF85 FAD XF	1500	800	930	790
XF series	1100	800	930	790

(1) The A, B, RBV and/or RBA values for FTT/FAT chassis with air-sprung rear axles may be different. Consult DAF for more information.

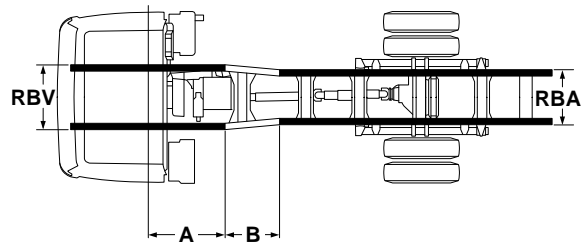

G000281

2

Cab-related dimensions and CB dimension for positioning of superstructure

For more details related to cab dimensions (for instance, for the space taken up by the bumper when the cab is tilted), see detail 'Z' of the bodybuilders' drawings.

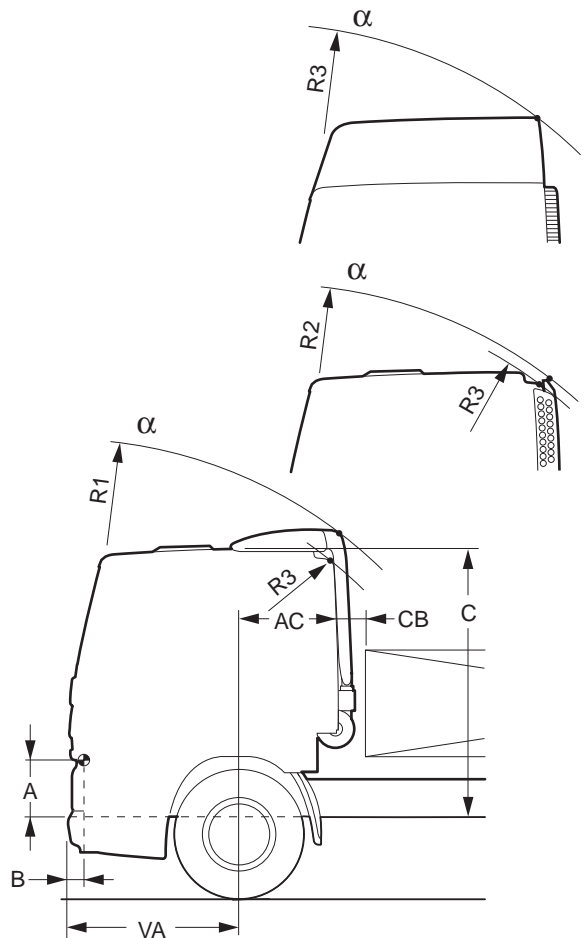

G001132-01

BODYBUILDERS' GUIDELINES

Chassis Information

Cab-related dimensions and CB dimension

Series	Cab	A	B	C ⁽²⁾	VA	AC	CB ⁽¹⁾	R1	R2	R3	α ⁽³⁾
LF 45	Day ⁽⁴⁾	141	122	2082	1275	330	70	2580	--	2450	53°
	Sleeper	141	122	2082	1275	730	70	2865	--	2715	53°
LF 55 (12-15t)	Day ⁽⁴⁾	209	44	2150	1325	280	70	2580	--	2450	55°
	Sleeper	209	44	2150	1325	680	70	2865	--	2715	55°
LF 55 (18-19t)	Day	209	44	2150	1375	230	120	2580	--	2450	55°
	Sleeper	209	44	2150	1375	630	70	2865	--	2715	55°
CF (Day)	(CF65)	320	110	2119	1380	390	160	2580	2350	2350	60°
	(CF75)	310									
	(CF85)	410									
CF (Sleeper)	(CF65)	320	110	2119	1380	820	150	2875	2670	2650	60°
	(CF75)	310									
	(CF85)	410									
CF (Space Cab)	(CF65)	320	110	2800	1380	820	150	--	--	3190	60°
	(CF75)	310									
	(CF85)	410									
XF105	Comfort Cab	500	100	2475	1370	880	190	--	--	2896	60°
	Space Cab	500	100	2775	1370	880	190	--	--	3095	60°
	Super Space Cab	500	100	3165	1370	880	190	--	--	3337	60°

(1) Distance between cab rear wall and superstructure front end, including minimum free space required. The listed values for LF45 and LF55 (12-15t) chassis are with 4 cylinder engine and for LF55 (18-19t) chassis with 6 cylinder engine and for all LF series with the coil type cab suspension.

Note: In the following situations a larger CB dimension is required:

LF series with:

- day cab LF55 and FR (4-cylinder) engine in combination with body installed on chassis without sub-frame: CB = 130 mm (extra clearance for gearshift lever)
- day cab and GR (6-cylinder) engine: CB = 130 mm
- high air intake: CB = 175 mm
- exhaust stack on LF45: CB = 182 mm
- exhaust stack on LF55: CB = 272
- vertical exhaust silencer on LF chassis: CB = 400 mm (air filter unit not included); CB = 660 mm (air intake filter unit included)

CF65

- exhaust stack: CB = 276 mm

CF75-85 series with:

- moisture separator unit fitted (positioned behind the cab rear wall): CB = 195 mm (day cab); CB = 175 mm (sleeper cab)
- cyclone filter with air intake opening positioned on top of the roofpanel: CB = 200 mm
- cyclone filter with air intake opening at the cab rear wall: CB = 160 mm (Day cab) or 150 mm (Sleeper cab)
- exhaust stack: CB = 240 mm
- exhaust stack with integrated vertical soot filter: CB = 370 mm

XF series with:

- cyclone filter: CB = 260 mm
- under-cab air intake: CB = 100 mm
- exhaust stack: CB = 240 mm (pipe end 90 transversely to driving direction)
- exhaust stack: CB = 340 mm (pipe end pointing backwards)

(2) Highest point air intake pipe fitted on cab roof: LF series day cab C + 130 mm, CF series C + 139 mm.

(3) Maximum tilt angle for LF Series may be limited if topsleeper is mounted on cab roof; check 5.2: "Maximum permissible additional cab weights".

(4) For LF45 with rubber-sprung cab: A = 151, B = 152, C = 2052, R1 = 2535, R3 = 2415.
For LF55 with rubber-sprung cab: A = 219, B = 74, C = 2120, R1 = 2535, R3 = 2415.

Chassis design

DAF uses specific designations for the different chassis types, in order to indicate their specific applications. See the survey below:

- Low-Deck tractor chassis 'LD'

Only available as an FT CF85 and XF tractor chassis, suitable for the lowest possible fifth wheel position and to combine with mega trailers (internal height ± 3 m).

- Low-Deck rigid truck chassis

Low rigid truck chassis (fully flat topped frame), previously referred to as (High-)Volume version '(G)V', with as standard 260 mm high side members; depending upon the version provided with lowered axle suspension and/or driving height compensation, suitable for (dismountable) bodies with maximum internal height. These vehicles require extra body strength or a sub-frame. See '(High-)volume body' in section 4: "Superstructures", or consult DAF for further information!

- - FA LF45 with GVM = 10 – 12 tonne long wheel base

FA LF45 chassis with wheel base longer than 5400 mm (available on request) and 192 mm high side members. These vehicles require extra body strength or a sub-frame. See in section 4.1: "Fixed body", or consult DAF for further information!

- UK tipper body

Available as 6x4 and 8x4 truck chassis (FAT and FAD), suitable for **light-weight tipper bodies without sub-frame**, specially developed for the British market. These chassis are ex-works provided with a short rear overhang, with a torsionally rigid cross member, and prepared for simple mounting of the tipping pivot. Consult DAF for further information.

These bodybuilders' guidelines are only applicable to vehicles which comply with standard DAF specifications, in accordance with the existing bodybuilders' drawings. In case of doubt, DAF should be consulted. Without a sub-frame, the standard chassis are designed for, and are at least suitable for, the transport of a uniformly distributed load at nominal permitted axle loads, with the exception of vehicles with 260 mm or 192 mm high side members with continuous inner reinforcement flitches, such as the Low-Deck versions or FA LF45. These vehicles require additional stiffness of a sub-frame or superstructure construction.

In case the load on the chassis is not equally divided extra care should be taken with regard to the tension levels in the chassis. For chassis material characteristics see table "Chassis specifications: Tractors and Rigid". When in doubt DAF Trucks could be

BODYBUILDERS' GUIDELINES

Chassis Information

2

consulted as mentioned in chapter 1.3: "Verificaton of superstructure". For subframe guidelines related to certain body types see the relevant text in the section 'Superstructures'.

Component location

DAF pays much attention to a bodybuilder-friendly positioning of all vehicle components in or on the outside of the chassis frame. In spite of this, for some body types a relocation of components may sometimes be necessary. For the CF75-85 and XF series, DAF uses the following starting positions: location of fuel tanks in front of the rear axle on the right-hand side (for the LF and CF65 series on the left-hand side, immediately behind the cab), leaving sufficient room for twist-locks and crane legs (compact exhaust silencer), standard free space for mudguards on the rear axle(s) and whenever possible no components on the rear overhang section of the chassis. For more detailed component location data, see the bodybuilders' drawings of the vehicle concerned.

2.11 DRAWBAR CROSS MEMBER

The rearmost cross member in the chassis may be constructed as an end beam (on rigids not used for truck/trailer combinations). This end beam is not suitable for the fitting of a towing hook or similar equipment.

The rearmost cross member can also be constructed as a drawbar cross member suitable for the fitting of a towing jaw. At all times the ex-factory supplied drawbar cross member and its carrying supports are build in accordance with the guidelines of directive 94/20EC. Also any non DAF drawbar construction and carrying supports that are submitted to DAF for approval must comply to the same directive.

On request, a drawbar cross member fitted in the required position can ex-works be supplied in combination with an adapted rear overhang (AE). However, if the definitive position will not be known until a later stage, an easy demountable drawbar cross member can be ordered ex-works, which for easy recognition, will be fitted in the chassis the wrong way round.

If necessary, a drawbar cross member fitted in the chassis may be relocated. When relocating a drawbar cross member, always use the **correct quantity** of attachment bolts of the **correct property class**.

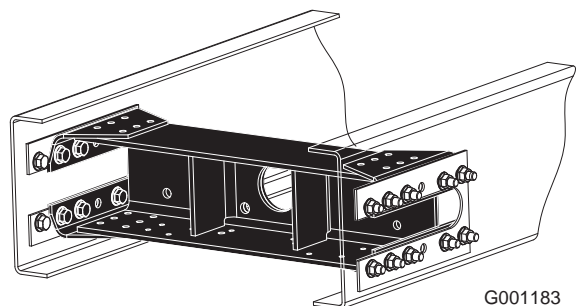

G001183



WARNING! Note that flange bolts must not be re-used, unless a new nut can be screwed along the full length of the bolt by hand. For the tightening torques of DAF flange bolts, see section 2.6: "Attachment of components to the chassis".

In normal circumstances (wheels pointing straight ahead, flat road), the position of the trailer drawbar must not deviate more than approx. 10° from an imaginary line parallel to the road.

If mid-axle trailers or trailers with a constrained steered close-coupling system are used which exert lateral forces on the rear overhang of the prime mover, the rear overhang of the prime mover should be fitted with internal lateral stiffeners up to the drawbar cross member, to guarantee sufficient directional stability of the trailer. These lateral stiffeners may consist of, for example, diagonal members (channel section, minimum height 60 mm) in the chassis frame or in the sub-frame (if fitted). However, if the prime mover is fitted with a torsionally rigid body, this extra stiffening is not necessary.

Mid-axle trailers are subject to a vertical load (S) on the towing eye. In combination with the distance between rear axle and coupling pin (AK), this vertical coupling load has an effect on the ride characteristics of the vehicle. This is the reason why the AK dimension is limited. See table 'Maximum AK dimension'.

D value

The D value is defined as the theoretical reference value for the **horizontal** force between the prime mover and the drawn vehicle and is therefore taken as a basis for the maximum load under dynamic conditions. The formulas below (I/II) can be used to determine the minimum D value required for the drawbar cross member or the maximum trailer weight.

Dc value

The Dc value is defined as the theoretical reference value for the **horizontal** force between the prime mover and the **mid-axle trailer** and is therefore taken as a basis for the maximum load under dynamic conditions. The formulas below (III/IV) can be used to determine the minimum Dc value required for the drawbar cross member or the maximum trailer weight:

GA = Maximum permissible mass of the drawn vehicle (tonnes)

GT = Maximum permissible mass of the pulling vehicle (tonnes)

$D = g \times \frac{GA \times GT}{GA + GT} \quad (I)$	$GA = \frac{GT \times D/g}{GT - D/g} \quad (II)$
$D_c = g \times \frac{GA \times GT'}{GA + GT'} \quad (III)$	$GA = \frac{GT' \times D_c/g}{GT' - D_c/g} \quad (IV)$

SE0001

(Also see the table of drawbar cross member data).

BODYBUILDERS' GUIDELINES

Chassis Information

2

- GT = Maximum permissible mass of the pulling vehicle including the vertical (static) load on the drawbar cross member. (tonnes)
- D = Value of the drawbar cross member (kN)
- g = Gravitational acceleration (≈ 10 m/s²)

The permissible D value depends on the dimensions of the drawbar cross member and the pattern of holes for the towing jaw; also see the table of drawbar cross member data below.

When determining the maximum permissible mass of the trailer, pay attention not only to the D/Dc value of the drawbar cross member and towing jaw, but also to any statutory requirements and the maximum value stated on the type approval certificate or on the vehicle registration document.

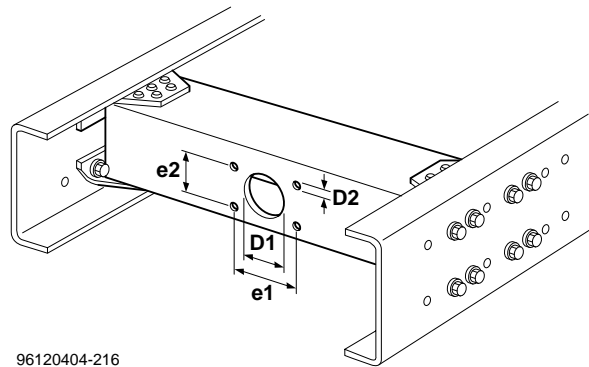

96120404-216

Standard drawbar cross member mounting in the chassis

V value

In some countries, it is not only the Dc value that is important for combinations with a **mid-axle trailer > 3.5 tonnes**, but the V value on the coupling also has to meet EC directive 94/20.

The V value is defined as the theoretical reference force for the amplitude of the **vertical** force between the prime mover and the mid-axle trailer and is therefore taken as a basis for the maximum load under dynamic conditions. The minimum required V value for the drawbar cross member can be determined using the formula below (III):

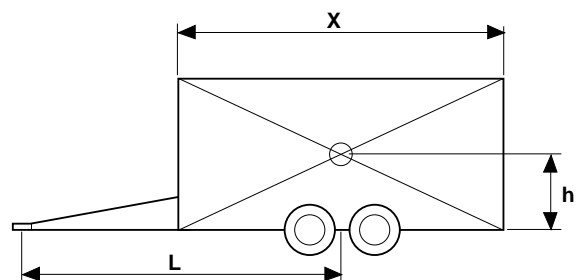

97122901-202

Dimensions of the mid-axle trailer

$$V = a \times \frac{X^2 \times C}{L^2} \quad \text{(III)}$$

SE0002

in all cases X^2/L^2 should be ≥ 1 ; see drawbar cross member data.

Where:

- a = Equivalent acceleration in the coupling point:
 ⇒ 1.8 m/s² for air-sprung prime mover, or
 ⇒ 2.4 m/s² for prime mover with other suspension system.
- X = Trailer body length. (metres)
- L = Distance between centre of trailing axle and end of drawbar. (metres)

$C = \sum$ axle loads of the trailer. (tonnes)
 $V = V$ value of the drawbar cross member. (kN)

In view of the high 'V' value usually required for the drawbar cross member when a mid-axle trailer is used, DAF advises the mounting of a D19 drawbar cross member in the case of a calculated V value of up to a maximum of 50kN (also see the table of drawbar cross member data).

Drawbar cross member data										
Vehicle type	D value [kN]	Dc value [kN]	V value [kN]	GA [tonnes] ⁽¹⁾	S vertical load [kg]	Bolt	D1	D2	e1	e2
Tractors										
FT CF75-85 and XF	43	-	-	-	-	M14	-	15	120	55
FTG/P CF85-XF	43	-	-	-	-	M14	-	15	120	55
FTS CF85 - XF FTR XF	43	-	-	-	-	M14	-	15	120	55
FTT CF85-XF	43	-	-	-	-	M14	-	15	120	55
FTM XF	43	-	-	-	-	M14	-	15	120	55
Rigids										
FA LF45	70	50	30	15	650	M14	75	15	120	55
FA LF55 13-15t	75	50	18	15	650	M14	75	15	120	55
FA LF55 16-18t FA CF65	100	70	25	25	900	M16	85	17	140	80
FA CF65 ⁽⁴⁾	130	90	28	25	1000	M20	95	21	160	100
CF75/85 and XF	130	90	28	40	1000	M20	95	21	160	100
CF75/85 and XF	190	120	50	65	1000	M20	95	21	160	100
Low version ⁽²⁾	114 ⁽³⁾	114	43.2	24	1000	M20	95	21	160	100

- (1) To be calculated according to formula II or IV, to a maximum permissible value as stated in the column. Specific and/or additional requirements may differ from country to country and further restrict the maximum trailer weight (GA).
- (2) For more information about this low-positioned DAF drawbar cross member, see the next paragraph.
- (3) Tested and released according to TÜV/EC requirements. When the D value is > 114 kN, the use of a mid-axle trailer is not allowed. However, $D_{max} = 130$ kN in countries where the TÜV/EC requirements do not have to be met.
- (4) Valid for CF65 chassis produced up to and including week 0512.

BODYBUILDERS' GUIDELINES

Chassis Information

Maximum AK dimension (centre-to-centre distance between rearmost axle and coupling)

V value [kN]	Drawbar cross member in rear overhang ^{(1) (2)}		Low-positioned DAF drawbar cross member ^{(1) (2)}	
	Single rear axle	Two or more rear axles	Single rear axle	Two or more rear axles
≤ 25	3000	3500	2300	2950
≤ 40	1900	2200	1450	1850
≤ 43.2	1750	2050	1350	1700
≤ 50	1550	1750	1150	1500

- (1) Additional requirements in the country concerned may further restrict the AK dimension. When using a drawbar cross member with a higher V value, consult DAF.
 (2) A vertical load on the coupling affects the axle load distribution of the prime mover; always verify that at least 30% of the total vehicle weight is under the front axle(s). See sub 1.6: "Weight distribution"

Low version

For the CF75/85 and XF series, a lower and more forwards positioned drawbar cross member can be ordered from DAF. When ordering such cross members, state the X and Y dimensions required. These drawbar cross members must be fitted in accordance with DAF's instructions. More information on its overall dimensions and chassis mounting position are available on the chassis detail drawing: 1668101 that is available on the Internet (Corporate DAF website: www.daf.com - > see item "Products"). If any non-DAF constructions are used, the dealer or bodybuilder should submit to DAF a drawing in duplicate for verification. For the legal requirements involved check the first paragraphs of this sub-chapter.

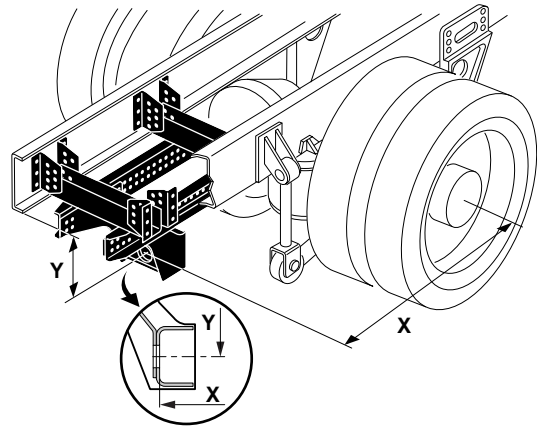

20090503-029

Distance between centre of rearmost axle and mounting face on the inside of drawbar cross member

Position of the low drawbar cross member in relation to the rearmost axle				
Series	Vehicle type ⁽⁴⁾	Type of suspension	Distance X (range): distance between centre of rearmost axle to mounting face on inside of drawbar cross member [mm]	Distance Y: range (maximum) [mm]
			X ⁽¹⁾	Y ⁽²⁾
XF and CF ⁽³⁾	FA / FAS ⁽⁵⁾ + (G)V	air suspension	from 690 to 1140	From 250 to 360
	FAR + (G)V	6-bellows air suspension	from 615 to 1065	from 250 to 360
		6-bellows air suspension	from 565 to 1065	from 272 to 360

- (1) Within this range, adjustment pitches for mounting the low-positioned drawbar cross member are 50 mm. Moving the coupling further to the rear, in combination with the use of mid-axle trailers, may have an adverse effect on the ride characteristics. Also take note of statutory requirements, which may differ from country to country. In case of doubt, DAF should be contacted.
- (2) Within this range, adjustment pitches for mounting the low-positioned drawbar cross member are 22 mm. One of six possible Y-positions can be ordered ex-factory, see the following table in this paragraph for the possibilities and their corresponding selection code numbers.
- (3) FA CF65 chassis from production week 0513 onwards are not included.
- (4) (G)V = Low deck chassis type (previously referred to as High Volume chassis).
- (5) Delivery of the lowered drawbar cross member for the FAS chassis on POV request only.

Overview of SELCO number and corresponding Y position ex-factory:

Selco number	Y position [mm] ⁽¹⁾
4948	250
4952	272
4953	294
4954	316
4955	338
4956	360

- (1) The X position can limit the choice for any of the available Y-positions. See the previous table for more details.

Centre-to-centre distance between rearmost axle and coupling (AK dimension)

Dimension AK is - dependent upon the make and type of the towing jaw - dimension X + 150/190 mm (± min/max). Care should be taken that, when the vehicle combination is placed in any position on a level surface, the space between prime mover and trailer is at all times sufficient to allow a kink angle of **at least 4°**.

BODYBUILDERS' GUIDELINES

Chassis Information

2

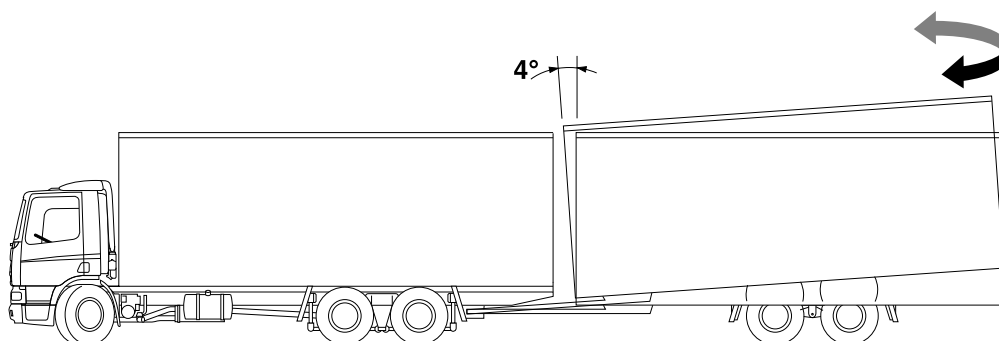

20061604-220

When a semi-low drawbar cross member is used, the dealer or bodybuilder should submit to DAF a drawing in duplicate for verification. For the legal requirements involved check the first paragraphs of this sub-chapter.

The mounting of a drawbar cross member in a tractor chassis for combined tractor/trailer applications is permitted in some cases. In such cases, DAF must always be consulted beforehand.

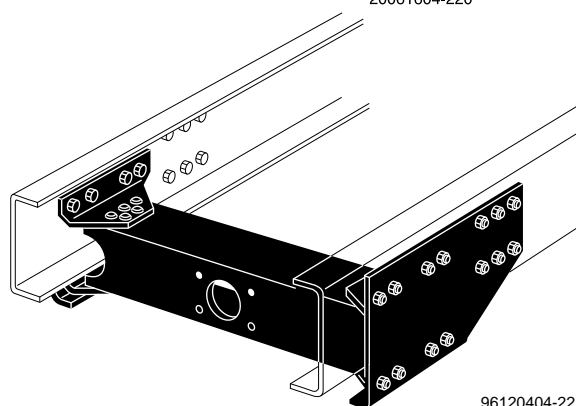

96120404-221

Semi-low drawbar cross member

2.12 REAR LIGHT BRACKETS

Chassis are always delivered with rear light brackets. If however, the rear light units are to be integrated into the body or superstructure then a so called 'transport' bracket could be ordered ex-factory. Be aware that this transport bracket which is a preformed metal sheet panel always must be replaced by a more solid construction.

2.13 WHEEL MOUNTING

All DAF vehicles have spigot-mounted wheels. For safe and trouble-free fitting of the wheels, it is most important that the mating surfaces of wheel rims and brake drums should be absolutely clean.

Any coat of paint must never be thicker than 0.05 mm. In practice this means that the old paint must be removed before applying a new coat.

Tighten the wheel nuts in a cross-wise sequence to the correct torque.

Wheel nut tightening torques ⁽¹⁾	
Wheel nut	Tightening torque [Nm]
M 18 x 1,5 - series FA LF45 - 7.5/08 tonnes and FTP non-steered second axle	340 - 400
M 20 x 1,5 - series FA LF45 - 10/12 tonnes, FA LF55 - 12 t/m 15 tonnes and FAN LF55 rear steered axle	450 - 520
M 22 x 1,5 - series LF55 - 18 t/m 19 tonnes, CF and XF	700

(1) All wheel nuts have RIGHT-HAND thread!

2.14 WHEEL CLEARANCE

To ensure sufficient all-round clearance for the wheels, proceed as follows when bodying the chassis and fitting mudguards or wheel housings:

1. Measure the maximum vertical axle movement "v" (metal to metal) on the vehicle.
2. Determine the total vertical space (s) by adding extra space (see table) to the vertical distance 'v', which is required for vertical axle movements and superstructure pitch and roll when cornering or during off-the-road operation.
3. Determine the lateral movement (b) of the tyres (see table). With steered axles, the maximum wheel turning angle should also be taken into account.
4. Note that on multi-axle vehicles the required wheel clearance may be different for the different axles of the vehicle.
5. Finally, it should be taken into account that (extra) space is required for a liftable second axle or rear steered axle and for a rigid trailing axle.

On tractor chassis with flexible plastic or rubber mudguards, which will only be used for operation on surfaced roads and under 'normal' conditions, the mudguards can be fitted without extra clearance. In that case, dimension 's' is equal to dimension 'v'!

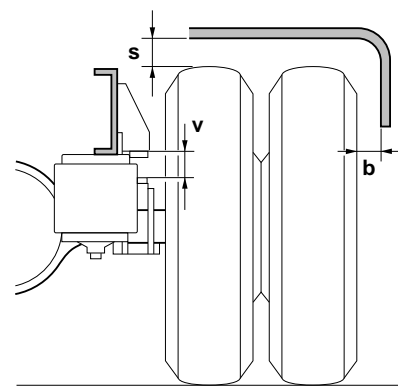

96120404-222

Air suspension

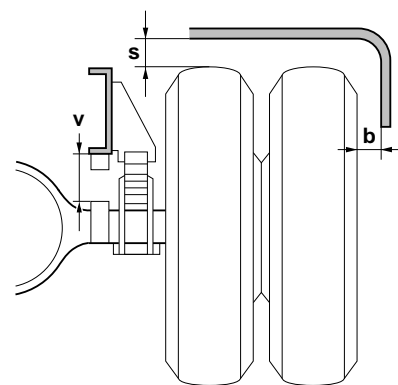

20090503-008

Leaf suspension

Wheel clearance			
Operating conditions	Extra space	Total space 's' ⁽¹⁾	Lateral space 'b'
Operation on normal roads	25	v + 25	15
Off-the-road operation	75	v + 75	25
With snow chains:			
- operation on normal roads	60	v + 60	60
- off-the-road operation	110	v + 110	70

(1) Not applicable to Low-Deck chassis.

BODYBUILDERS' GUIDELINES

Chassis Information

2

Clearance dimension

If the chassis to be bodied is not yet available, the wheel clearance can also be determined on the basis of the bodybuilders' drawing. The chassis height and the HBV/HBT/HBA dimension (metal to metal) can be established from this drawing. To determine the clearance dimension (U), the extra space needed as indicated in the above table may have to be added to the calculated HBV/HBT/HBA dimension.

Each bodybuilders' chassis drawing refers to drawing No. **1260799/..** (CF75-85 and XF series) or **NSEA383/..** (LF and CF65 series) which shows a number of general vehicle data, such as tyre radius, wheel track and maximum width of the various front and rear axles. This drawing (of course, the one with the latest modification index!) should always be consulted.

The above-mentioned bodybuilders' drawings and drawing No. 1260799 are included on the TOPEC-CD ROM and available on the internet (www.daf.com).

Chassis heights

The chassis heights at the front axle (HV dimension) and rear axle (HA dimension) can, for the most commonly used tyre sizes (dimensions according to ETRTO standard), be determined using the TOPEC chassis height calculation program. The height of the tyre above the chassis (HBV/HBT/HBA dimension) and the clearance dimension (U) for the driven rear axle are also indicated.

The formulas for calculating the chassis heights and the corresponding values on the basis of the DAF bodybuilders' drawings are given below:

Determining the chassis height on the basis of the bodybuilders' drawing ⁽³⁾	
FRONT AXLE:	$HV = R + Y + A$ ⁽²⁾ $AHV(\text{min.}) = R - C$
REAR AXLE:	$HA = R + Z + A$ ⁽²⁾ $AHA(\text{min.}) = R - D$
	$HBV(\text{max.}) = Ro - A - Z$, metal to metal, at the driven axle.
	$HBA(\text{max.}) = Ro - A - X$, metal to metal, at the trailing axle. $HBA(\text{max.}) = Ro - A - Z$, metal to metal, at the second driven axle
	$HBT(\text{max.}) = Ro - A - V$, metal to metal, at the second front / (non)steered leading rear axle
	$U = HBV + 25 \text{ mm.}$ ⁽¹⁾
	$AHA(\text{min.}) = R - D$

(1) The U dimension given here applies to operation on normal roads. For other operating conditions, see the paragraph 'Driving conditions'.

(2) The calculated chassis heights only apply to the places in the bodybuilders' drawings that are marked HV and HA.

(3) For chassis weights that are not mentioned in the bodybuilders' drawings, you should consult the DAF specification sheets and/or (if you have them) the TOPEC layout calculation data.

The parameters indicated in these formulas can be found in the bodybuilders' drawings concerned. They can also be derived from the above-mentioned drawing 1260799. Therefore, always also refer to this detailed drawing.

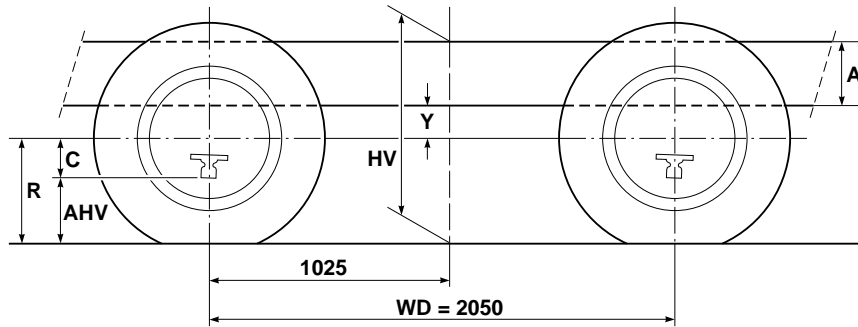

22032802-038

Twin front axle, chassis height

Driving conditions

Dimension **U** is the minimum clearance between the top of the chassis side member and the underside of the floor of the body or the mudguard under normal operating conditions. Additional wheel clearance is required under different driving conditions:

- when snow chains are used: $U' = U + 35 \text{ mm}$
- for off-the-road operation: $U' = U + 50 \text{ mm}$
- for off-the-road operation: + snow chains: $U' = U + 85 \text{ mm}$

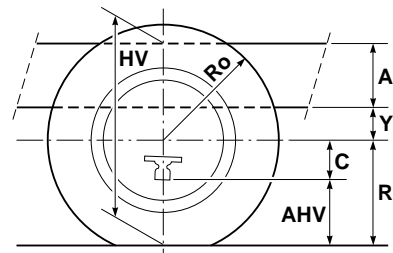

96120404-224

Single front axle, chassis height

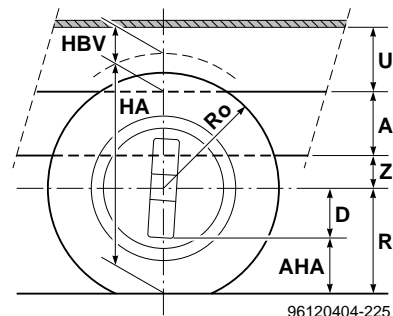

96120404-225

Rear axle, chassis height wheel clearance/ clearance U

BODYBUILDERS' GUIDELINES

Chassis Information



WARNING! For multi-axle vehicles, it should be established which axle is decisive for the minimum clearance dimension; also see the relevant bodybuilders' drawing.



WARNING! Always also make a check on the vehicle to verify the dimensions.

2

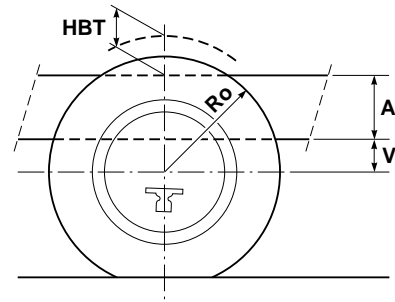

G000359

2nd front axle/second steered axle; tyre above the chassis

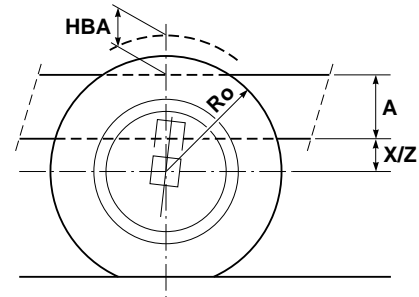

G000360

Trailing axle/rear steered axle (X) or second driven rear axle (Z); tyre above the chassis

2.15 LOCATION OF THE MUDGUARDS

On vehicles of the LF55 and CF series, the **front mudguards** can be fitted in different places. Their location depends on the vehicle type and on the wheels and tyres ordered by the customer.

Location of mudguards					
Size	LF55 18-19t	CF65 (1)	CF		
			Low	Medium	High
A	835	778	778	778	778
B	778	527	372	464	517
C	530	584	457	540	575
D	-	-	398	498	541
E	91	240	240	240	240

(1) Values valid for CF65 chassis produced from week 13 2005 onwards (V.I.N. code: XLRAE65CC0E677039).

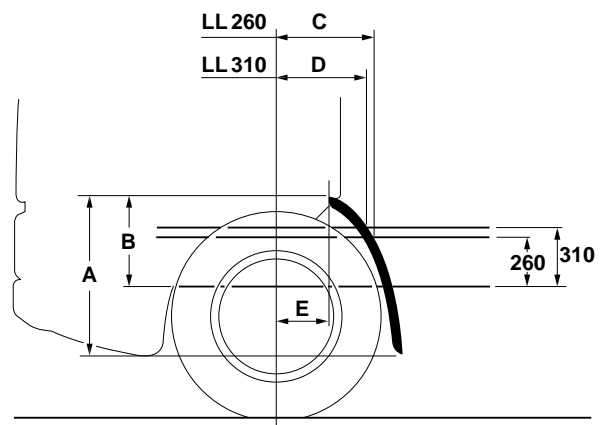

20090503-007

Position of front mudguards on LF55 and CF series

Mudguards are factory-mounted in accordance with the 91/226/EC directive. However, if the statutory requirements for mudguards do not apply, the mudguards are fitted in the high position as standard.

On the **short cabs** of the CF vehicle series, the superstructure may in certain situations come in the way of the factory-mounted front mudguards. If this is the case, and the problem cannot be solved by using a lower mounting position, the plastic flaps may be sawn off. However, they must never be sawn off lower than the top of the side members. Of course, the bodybuilder should in such cases ensure that wheel protection provisions are refitted in accordance with legal requirements.

If, on a leaf-sprung vehicle, the **rear mudguards** cannot be attached to the sub-frame or to the body, they may be bolted to the chassis side members. Wherever possible, use the existing holes in the chassis. Air-sprung vehicles already have tapped holes for this purpose in the torque rod bracket.

For some tractor chassis, DAF also has standard brackets, which can be used to fit the mudguards to the chassis at various heights, depending on the tyre size.

Tractors can ex-works be supplied with these (3-piece) rear mudguards.

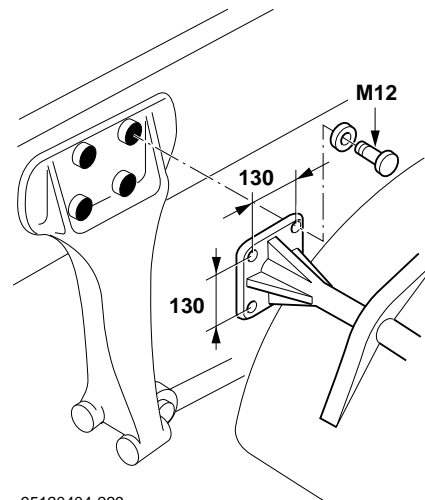

95120404-229

Air-sprung driven axle (FA LF55 16-18 tonnes, CF and XF series) mounting of bracket

2.16 EC-APPROVED REAR UNDERRUN PROTECTION

An EC-approved rear underrun protection beam (with EC certificate No. E4-70/221/92006) is available as an option for certain vehicles. A general exception are the Low-Deck rigid truck chassis (High volume vehicles). For CF75-85 and XF chassis there is a choice of three standard heights for ex-works rear underrun protection beams: 270 mm, 300 mm or 330 mm below the chassis. For LF and CF65 chassis one height of the rear underrun protection beam (245 mm) is available ex-works. If required, the beam can also be ordered and mounted separately.

The rear underrun protection beam according the EC legislation, must be mounted at the following position;

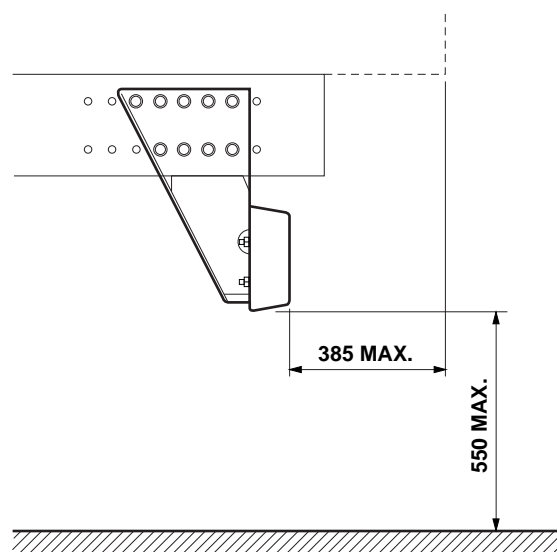

G000274

BODYBUILDERS' GUIDELINES

Chassis Information

- Maximum 550 mm above the road surface, in all situations, laden and unladen vehicle.
- Maximum horizontal distance 385 mm, from the rear end of the vehicle up to the rear end of the underrun protection beam. This 385 mm is based on the maximum legal distance of 400 mm including deformation when a test load has been applied.

2

2.17 AUTOMATIC LUBRICATION

The vehicle series that are ex-works supplied with a **lubrication system** can in some cases be given a number of extra lubrication points for the superstructure. Depending upon vehicle application, the vehicle type in question and the required number of lubrication points on the superstructure, a tee piece may be fitted to the pump, which enables the fitting of a second main pipe, running in parallel with the existing system. There are no restrictions for the length of the added main pipe between pump and distribution point. However, the length of the pipe between distribution point and lubrication point is restricted to a maximum of 5 metres. For further information, DAF should be contacted.

GENERAL INFORMATION ON SUPERSTRUCTURES

	Page	Date
3.1 Superstructure with sub-frame	45	201019
3.2 BAM's - body attachment methods	49	201019
3.3 First attachment point	55	201019
3.4 Type of superstructure/BAM matrix	57	201019
3.5 BAM instructions, general	58	201019
3.6 FA LF45	60	201019
3.7 FA LF55	64	201019
3.8 FA LF55 18t	68	201019
3.9 FA CF65	72	201019
3.10 FA CF and XF	76	201019
3.11 FAR/FAS CF and XF	79	201019
3.12 FAG CF	82	201019
3.13 FAN LF	85	201019
3.14 FAN CF and XF	88	201019
3.15 FAT CF and XF	91	201019
3.16 FAC/FAX CF	94	201019
3.17 FAD CF and XF	96	201019
3.18 FAK CF and XF	98	201019

BODYBUILDERS' GUIDELINES

General information on superstructures

3

3. GENERAL INFORMATION ON SUPERSTRUCTURES

3.1 SUPERSTRUCTURE WITH SUB-FRAME

For a large number of superstructure types, it is necessary to fit a sub-frame on the chassis, not to ensure structural strength and rigidity of the chassis but to obtain sufficient wheel clearance. For this purpose a **non-rigid attachment** is required. The use of a sub-frame gives an even distribution of load, creates sufficient wheel clearance and enables extra components and/or units to be fitted. As a rule, a material (such as aluminium) which is of lower quality than that of the chassis side members can be used for the sub-frame. If, however, the chassis is subjected to higher loads or stresses, the dimensions of the sub-frame should be determined taking account of the anticipated loads, and a **rigid attachment** is required, using attachment plates.

Construction of the sub-frame

The following instructions apply to the construction and attachment of all sub-frames:

- The sub-frame should run the full length of the chassis frame **without joints**. A sub-frame **extending far to the front** also reduces the risk of annoying (speed-dependent) natural frequencies, the so-called bending vibrations, which in some cases may also adversely affect the driving comfort. The front end of the sub-frame, before the first attachment point, should be tapered or dove-tailed to prevent an unnecessarily abrupt change in rigidity between the sub-frame and the chassis frame. Finally, to prevent notching, the front end of the sub-frame must be rounded off on the underside. The radius should be at least 5 mm.
- A channel section (minimum thickness 5 mm) is generally best suited for side member sub-frames. For some applications, e.g. a vehicle loader, it may be necessary to close off the channel section on a part of the sub-frame, so that a box section is formed. In that case, a gradual transition of rigidity should again be guaranteed by dove-tailing.

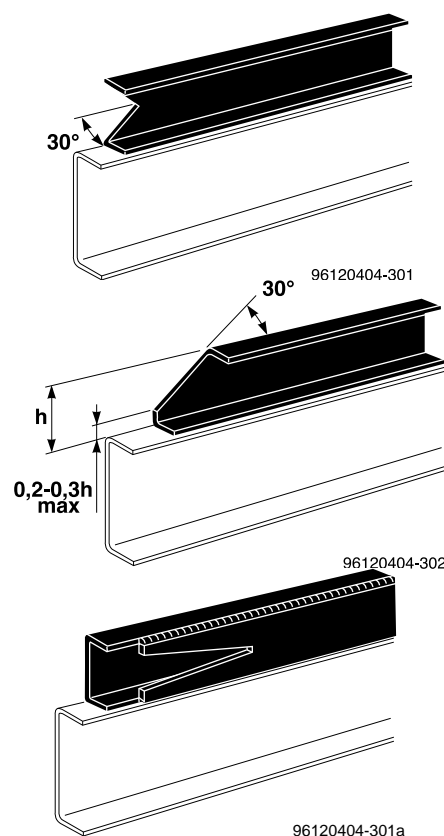

BODYBUILDERS' GUIDELINES

General information on superstructures

3

- In the case of a rigid attachment of the sub-frame to the chassis, the material with the lowest mechanical properties is always decisive for the strength and stiffness of the structure. It is therefore then preferable to make the sub-frame from a material which is at least of the same quality as that of the chassis frame; see the overview of side member dimensions in section 2.10: "Chassis and cabine related dimensions". If a material **other than steel** is used for a rigidly attached sub-frame, the shape and dimensions must be determined taking account of the specific characteristics of the material in question. Consult DAF for more information.
- The sectional pattern of a construction must always be uniform. Each addition in the form of construction reinforcements must continue to guarantee a uniform pattern of the linear moment of inertia. If, for any reason, the sub-frame height is decreased or increased in some places, always ensure that there is a gradual transition of rigidity.
- The maximum permissible distance between one cross member and the next in or on top of a sub-frame is 1200 mm.
- The height of the sub-frame cross members must be at least 0.6 times the height of the sub-frame side members. The sub-frame cross members should be fitted in such a way that they can follow the movements of the chassis frame.
- Cross members should preferably **not** be welded to the sub-frame flanges.

Any vertical forces exerted on the chassis should be introduced via the side member webs and not via the side member flanges! The upper (and lower) flanges only serve to add sufficient strength and stiffness to the section, and they can easily be deformed if incorrectly loaded by transverse forces exerted on the flange ends. If this happens nonetheless, the inside of the section (between the flanges) should be adequately reinforced, so that deformation and/or damage are prevented. Clamped joint to the flanges are forbidden.

Filler between chassis and sub-frame

If a filler has to be fitted between the chassis frame and the sub-frame (for example in the case of an aluminium sub-frame), always use a form-retaining filler (preferably plastic) over the full length.

Never fit a filler in the case of totally or partly rigid attachment of the sub-frame (BAM 2, 3 and 4).

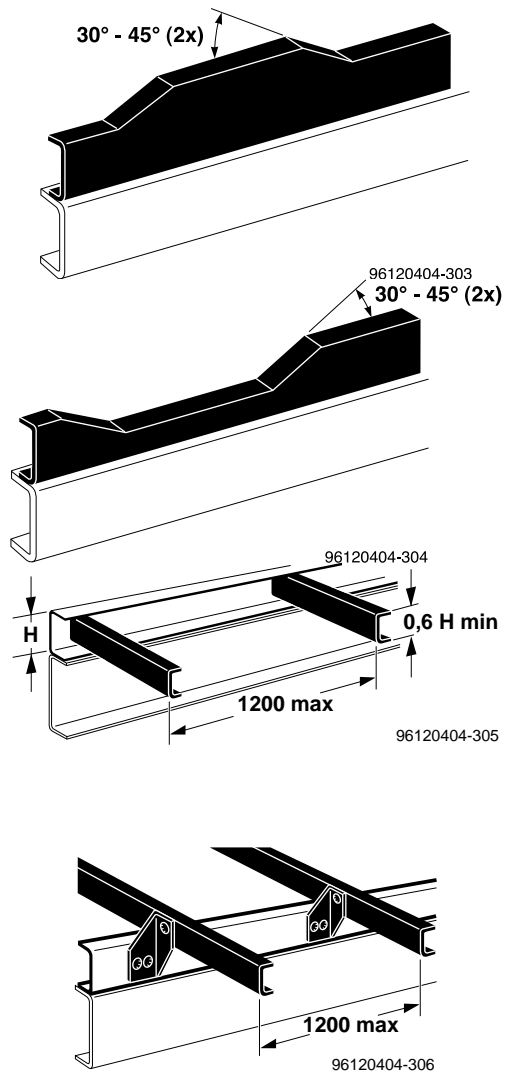

Stability by torsional stiffening of the sub-frame

For some (deforming) superstructures, vehicle stability requires torsional stiffening of the rear overhang. This stiffening can consist of parts of the body (e.g. a tipping stabiliser), separate torsionally stiff cross members or cruciform braces fitted in the sub-frame; see the figures opposite. Where necessary, this is stated in the relevant text of section 4: "Superstructures".



NOTE: The cruciform braces must be fitted as close as possible to the chassis frame and starting from 1000 mm in front of the centre line of the last axle up to the end of the sub-frame.

Vehicle stability during operation of any superstructure system is the responsibility of the bodybuilder and the user. The user should at all times make sure that vehicle stability is guaranteed. It is therefore important that clear instructions for use of the superstructure should be provided on or supplied with the vehicle.

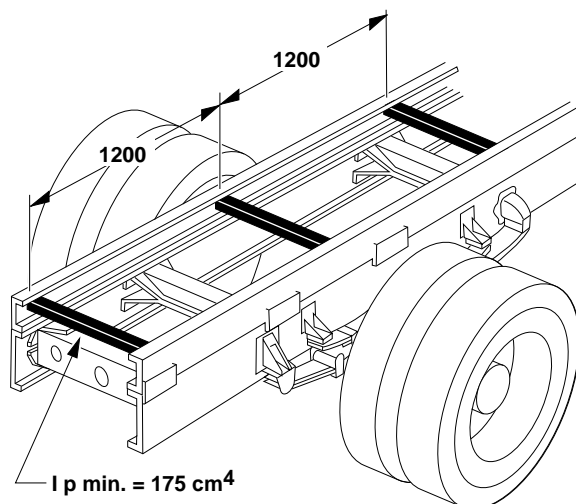

96120404-307

Cross members for torsional stiffening

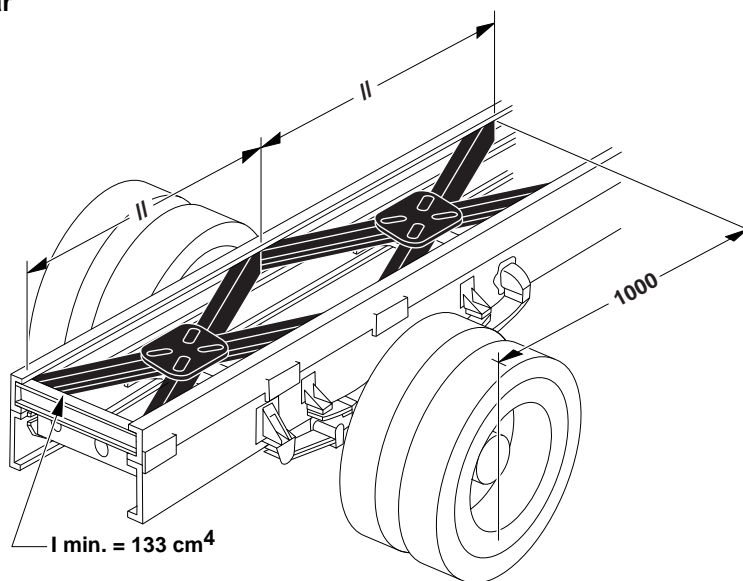

G000436

Cruciform bracing for torsional stiffening

BODYBUILDERS' GUIDELINES

General information on superstructures

Comparative table for sub-frame sections

Section designation ⁽¹⁾	Area of cross section [cm ²]	Specific weight of the section M [kg/m]	Moment of resistance W _x at vertical loa [cm ³]	Linear moment of inertia I _x at vertical loa [cm ⁴]
Hot-rolled channel section				
UNP 60	6,5	5,17	10,5	31,6
UNP 65	9,0	7,2	17,7	57,5
UNP 80	11,0	8,9	26,5	106,0
UNP 100	13,5	10,8	41,2	206,0
UNP 120	17,0	13,7	60,7	364,0
UNP 140	20,4	16,4	86,4	605,0
UNP 160	24,0	19,2	116,0	925,0
UNP 180	28,0	22,5	150,0	1350,0
Cold-rolled channel section				
U 60x30x4	4,36	3,49	7,8	23,5
U 60x40x4	5,16	4,13	9,9	29,8
U 80x50x6	9,80	7,8	24,5	98,0
U 100x50x6	11,0	8,8	33,4	166,8
U 100x60x4	8,36	6,69	27,3	136,6
U 100x65x6	12,8	10,24	41,3	206,6
U 120x60x5	11,3	9,0	42,3	254,0
U 120x60x6	13,4	10,7	49,5	297,1
U 140x60x4	9,9	8,0	42,7	298,7
U 140x60x6	14,6	11,7	61,2	428,3
U 160x60x6	15,8	12,6	73,7	589,2
U 160x70x5	14,3	11,4	70,2	561,2
U 180x60x5	14,3	11,4	73,8	664,2
U 180x60x6	16,9	12,9	83,9	755
U 200x60x6	18,1	13,9	97,6	976
Box section				
□ 80x80x6	17,2	13,9	40,7	163
□ 80x80x7	20,4	16,0	45,8	183,2
□ 80x100x8	26,2	20,6	60,8	243,2
□ 80x120x8	29,4	23,1	71,2	284,8
□ 100x100x8	29,4	23,1	83,7	418,4
□ 100x120x7	28,8	22,6	87,6	438,1
□ 100x150x8	37,4	29,4	117,6	588,1
□ 120x120x8	35,8	28,1	125,5	753,1
□ 120x120x10	44,0	34,5	149,1	894,7
□ 120x120x12	48,0	40,7	151,5	959,4
□ 140x140x12	61,4	48,2	241,8	1692
□ 150x150x12	66,2	51,5	282,4	2118

(1) The table above gives information about some of the most commonly used sub-frame sections. This table may also be useful for the selection of alternative materials with similar properties. The dimensions, weights and static data apply to sections without flitches!

3.2 BAM'S - BODY ATTACHMENT METHODS

BAM (Body Attachment Method) type - overview

DAF uses **five** body attachment methods (BAM 1, 2, 3, 4 and 5) for the mounting of superstructures. By using one of three basic attachment techniques (or a combination of them), an optimum and homogeneous superstructure and chassis attachment can be realised for each type of superstructure. The basic techniques are: non-rigid attachment, rigid attachment and attachment with consoles.

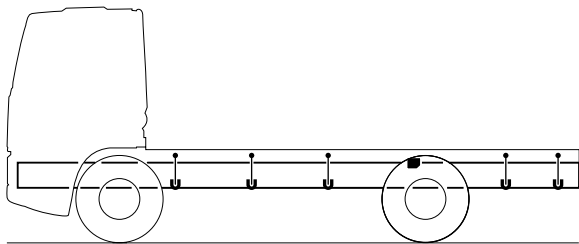

96120404-309

BAM 1: fully non-rigid attachment (CF75-85 and XF Series)

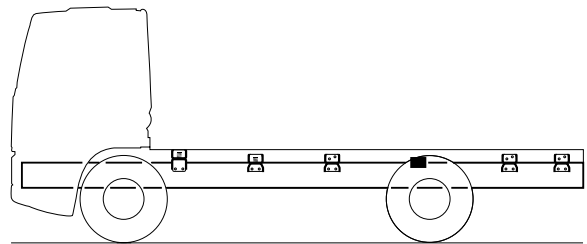

G000429

BAM 1: fully non-rigid attachment (LF and CF65 Series)

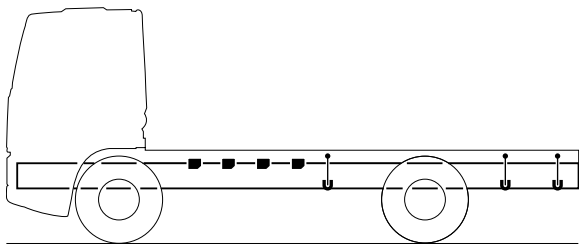

96120404-310

BAM 2: rigid attachment at front (CF75-85 and XF Series)

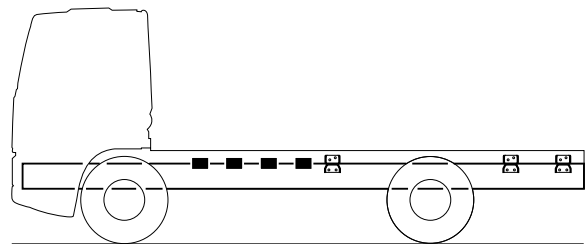

G000430

BAM 2: rigid attachment at front (LF and CF65 Series)

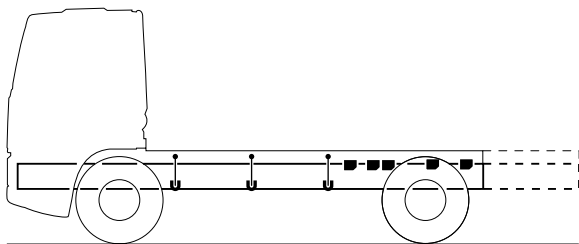

96120404-311

BAM 3a + 3b: rigid attachment at rear (CF75-85 and XF Series)

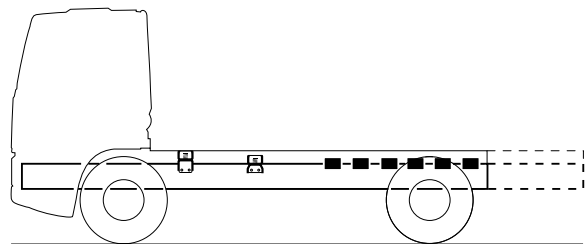

G000431

BAM 3: rigid attachment at rear (LF and CF65 Series)

BODYBUILDERS' GUIDELINES

General information on superstructures

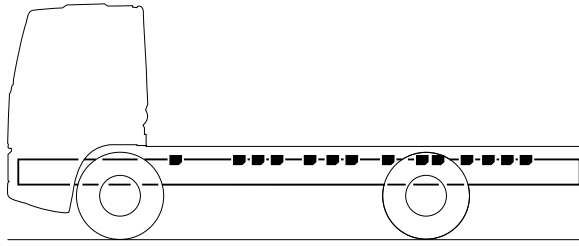

BAM 4: fully rigid attachment

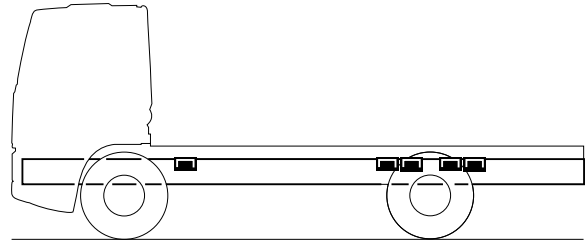

BAM 5: attachment with consoles

3

Three attachment techniques

DAF uses three basic attachment techniques for the mounting of superstructures. By using one of these three attachment techniques (or a combination of them), an optimum and homogeneous superstructure and chassis attachment can be realised for each type of superstructure. DAF's superstructure attachment techniques are based on state-of-the-art technological knowledge in the field of chassis stiffness and spring systems. Observation of the attachment recommendations guarantees that the dynamic behaviour of the bodied vehicle will be the same as defined and tested by DAF.

- Tie rods

The tie rod attachment technique provides a **non-rigid** connection. It allows limited displacement of the superstructure in the longitudinal direction. This gives little resistance to torsion, so that, while driving on bumpy roads, the chassis frame and the superstructure will be able to follow each other well. The result is a good balance between road grip and ride comfort.

Tightening torque of M16 nut for tie rod (CF75-85 and XF series): 55 Nm

- A:** = 60 mm for CF75-85 series
= 60 - 70 mm for XF series

This technique can be used for a superstructure with or without sub-frame, in accordance with the following guidelines:

- When using this attachment technique, always fit **at least one attachment plate** near the rear axle, for superstructure fixation in the longitudinal direction.
- The attachment brackets should be mounted with flange bolts near the cross member attachment points in the chassis frame. The maximum permissible distance between the tie rods is **1200 mm**. The tie rod should be located against the side member, so that lateral displacement of the sub-frame or superstructure is prevented.
- The tie rod should have a working **length** of at least **150 mm**. A tie rod may be bolted or welded to a superstructure cross member or to the sub-frame. Tie rods should always be placed in a vertical position.
- As an alternative, an M16 stud of this length may also be used.
- The **property class** of the tie rod material should in any case be **at least 8.8**.
- If the tie rods are bolted to the sub-frame, the thickness of the sub-frame should at least be 5 mm.
- Always use self-locking nuts or locknuts for the attachment of tie rods.

For the tightening torques of DAF flange bolts, see section 2.6: "Attachment of components to the chassis".

- Consoles

DAF distinguishes console models that are mounted to the vertical section of the chassis profile (model A) and consoles that additionally are supported by the upper flange of the main chassis longitudinal (model B). Due to its specific features DAF advises the console model B with additional chassis flange support to be used for BAM 5 attachment (described further down this chapter).

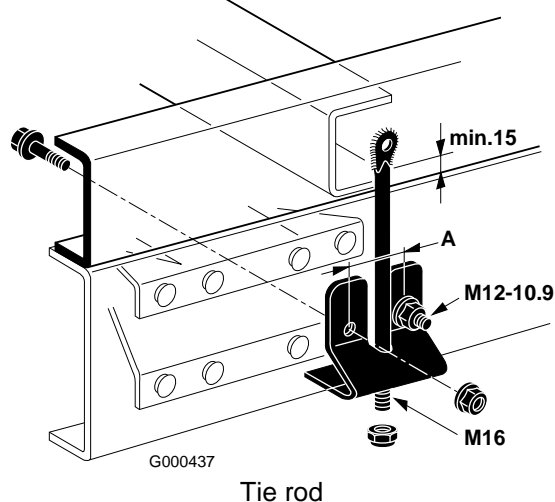
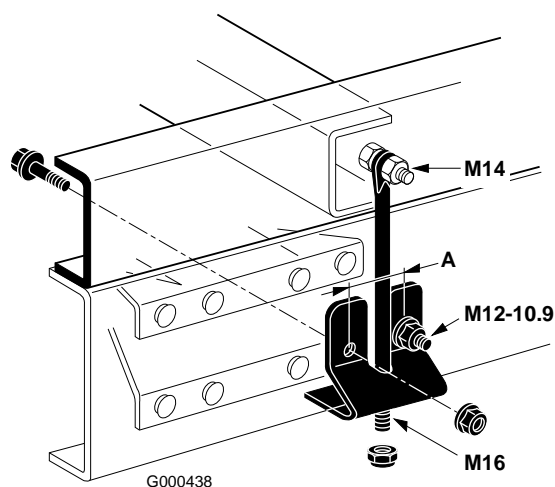

Tie rod

BODYBUILDERS' GUIDELINES

General information on superstructures

Console; model A (LF and CF65 only)

These consoles can be equipped with or without pressure springs to provide a non-rigid or rigid connection similar to the tie rod and attachment plate connection that is described further down in this chapter.



WARNING! *The rigid connection with DAF type console may however not be classified equal to the attachment plate connection due to the differences in dimensional features and the number of fasteners used.*

3

This technique can be used for superstructures with a sub-frame, in accordance with the following guidelines:

- The mating surfaces of the console with the sub-frame and with the chassis frame should be free from paint and impurities. The only coating allowed is a thin layer of primer (thickness 17 - 25 µm).
- DAF supplied consoles have elongated fixing holes in their flanges. Therefore only flanged bolts and nuts should be used to fasten DAF consoles to the sub-frame consoles or brackets. Non flanged fasteners may only be used in combination with 4 mm thick washers with an outside diameter of at least 34 mm under the nut and bolt heads.
- When pressure springs are used, the pre-tension of each spring should be 1,5kN. For DAF-supplied springs, the specified pre-tension is obtained by compressing the springs to a length of 70 mm. The springs can be fitted on the upper console of the sub-frame or under the lower console of the chassis longitudinal.
- For the rigid attachment method the consoles must be positioned in such a way that the touching surfaces have contact over the full length with no gap in between them. This will avoid unnecessary stress in the console flanges, sub-frame and chassis longitudinal.

For the tightening torques of DAF flange bolts, see section 2.6: "Attachment of components to the chassis".

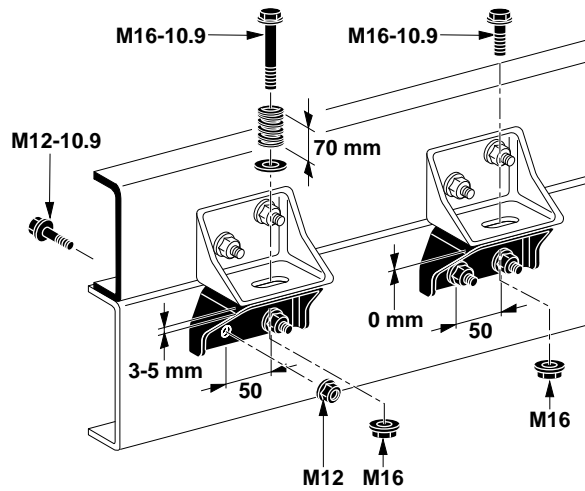

G000441

Consoles (model A) with and without pressure spring

- Attachment plates

Attachment using attachment plates gives a **rigid connection** between the superstructure sub-frame and the chassis frame (provided that sufficient flange bolts are used), so that the sub-frame contributes to the strength and stiffness of the chassis frame.

- A:** M12 - 10.9 (LF45 ,LF55 and CF65 series)
M16 - 10.9 (CF75-CF85 and XF series)

Rigid attachment with attachment plates is only used where necessary for the strength of the construction.

This technique can only be used for superstructures with a sub-frame, in accordance with the following guidelines:

- The mating surfaces of the attachment plate with the sub-frame and with the chassis frame should be free from paint and impurities. The only coating allowed is a thin layer of primer (thickness 17 - 25 µm).
- When mounting the attachment plates, wherever possible use the holes in the chassis specially provided for this purpose.
- If no sub-frame is used and the superstructure is mounted with tie rods, one attachment plate should be fitted to an extra connection between two superstructure cross members (near the rear axle) for superstructure fixation in the longitudinal direction. This should be done in accordance with BAM 1.

For the tightening torques of DAF flange bolts, see section 2.6: "Attachment of components to the chassis".



NOTE: Attachment plates on LF and CF65 chassis, if ordered ex-factory, are fitted close to and above the rear axle on the second, third and fourth (13 mm) bolt hole of the standard predrilled set of four.

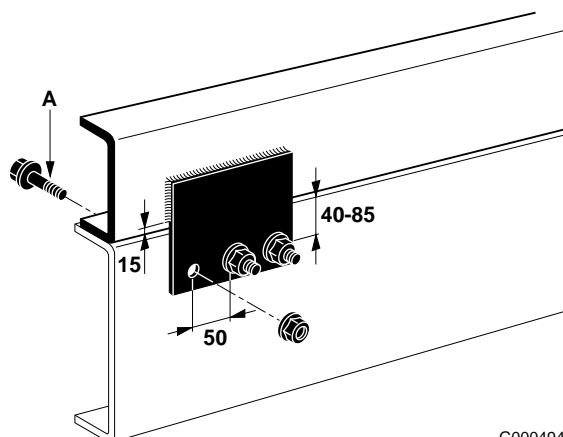

Attachment plate position (CF75-85 and XF chassis)

G000494

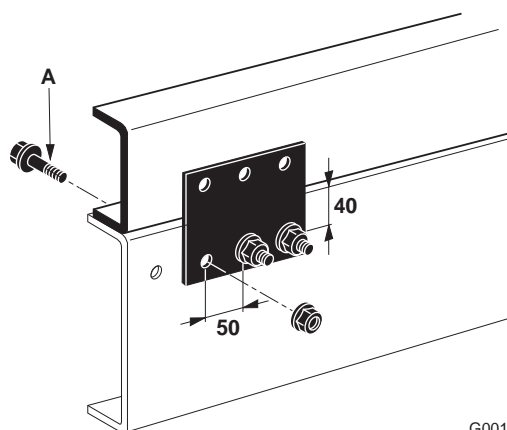

Attachment plate position (LF and CF65 chassis)

G001182

BODYBUILDERS' GUIDELINES

General information on superstructures

- Consoles; model B (for BAM 5 attachment)

Console attachment enables torsionally rigid superstructures, such as tanks and similar constructions, to be mounted to the chassis frame without overloading the superstructure or the chassis. The attachments must be made in such a way that torsional movement of the chassis is not hindered when driving on bumpy roads.

This technique can be used for superstructures without a sub-frame, in accordance with the following guidelines:

- Consoles must guide the superstructure in both transverse and longitudinal direction. In the vertical direction, only slight movement is permitted resulting from torsion occurring in the chassis. Superstructure-to-console attachment can be a fixed attachment or an attachment with pressure springs, depending on the type of superstructure and the operating conditions.
- For a fixed superstructure-to-console attachment, spacer bushes with a length of at least 30 mm should always be fitted to permit the use of bolts that are long enough to allow some degree of stretch.
- In relation with a vertical static console load of 20 kN two pressure springs should be used, the pre-tension of each spring should be 3 kN. The minimum spring rate per spring is 225 N/mm.
- The console attachment introduces a local vertical point load which results in local stress in the chassis. Therefore the chassis longitudinal must be reinforced with an innerliner, in case there is no innerliner reinforcement a subframe must be mounted.
- The console attachment might also introduce lateral torsion on the longitudinal. This torsion must be eliminated by a cross member supporting the longitudinal from the inside. See section 2.6: "Attachment of components to the chassis".

For the tightening torques of DAF flange bolts, see section 2.6: "Attachment of components to the chassis".

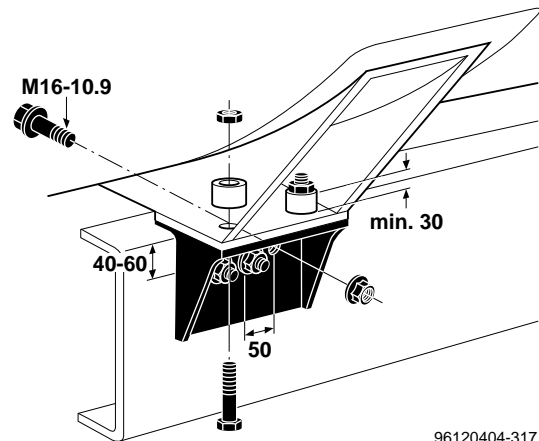

Console (model B) with fixed attachment

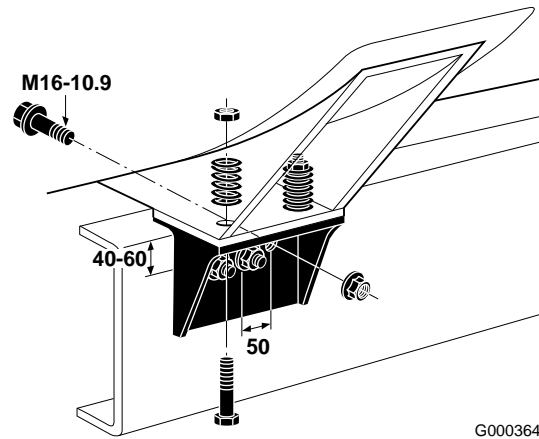

Console (model B) with pressure springs

3.3 FIRST ATTACHMENT POINT

First attachment point

The DAF chassis has a provision for the first (non-rigid) attachment point for BAM 1 and BAM 3 attachment methods.

If this attachment does not concern a bracket for the DAF tie rod, but another bracket or a threaded hole in a spring bracket, a normal M16 stud (property class 8.8) should be used. The working length of this stud should also be at least 150 mm. The console or plate used to fit this stud to the sub-frame, should **at all times project at least 30 mm downwards along the chassis frame**. This is necessary to prevent lateral displacement of the sub-frame.

On LF and CF65 series with non rigid attachment at the front end (BAM 1 + 3) the first and second console must at all times be equipped with a pressure loaded spring to ensure a sufficient non-rigid attachment. To prevent lateral displacement of the sub-frame either the first console must be projected at least 30 mm above the chassis frame or an additional restraint plate must be fitted on the sub-frame projecting at least 30 mm downwards along the chassis frame. Check previous chapter for more detailed information.

For some examples of first attachment points, which can be found on various vehicle series, see the illustrations in this section.



NOTE: Consult the table at the end of this chapter for factory-prepared positions of the first attachment point in relation to the front axle centre line .

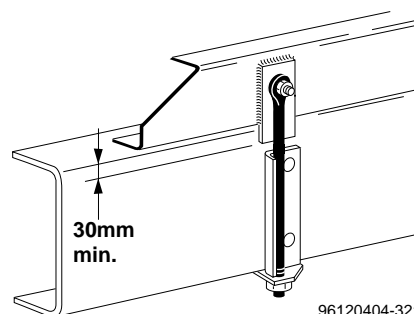

96120404-321

First attachment, CF75-85 and XF series

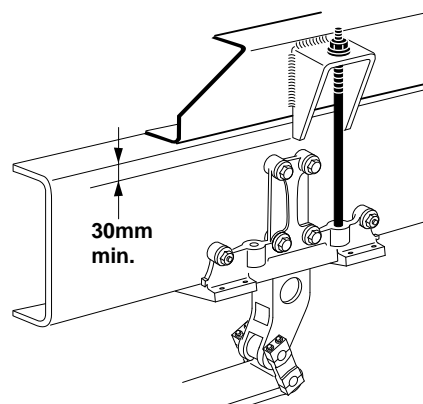

20081102-005

With stud in spring bracket, CF75-85 and XF series

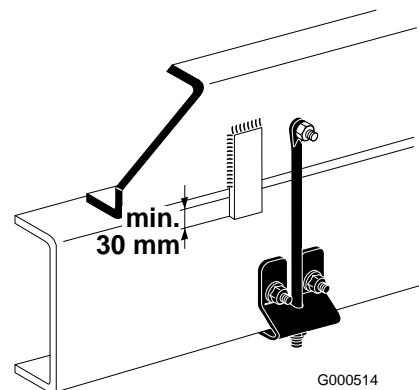

G000514

First attachment, FAT CF75-85 series with day cab (no vertical exhaust system)

BODYBUILDERS' GUIDELINES

General information on superstructures

Exception

Under extreme conditions, as is for instance the case with torsionally rigid superstructure constructions, a somewhat flexible attachment at the first attachment point is recommended. To this end, springs or rubber can be used. The degree of flexibility required depends on the operating conditions (area of application), the relative torsional stiffness of the superstructure and the experience of bodybuilders in similar situations. The springs of the DAF range may also be used for this purpose. See section 8: 'Order numbers of DAF parts'.

3

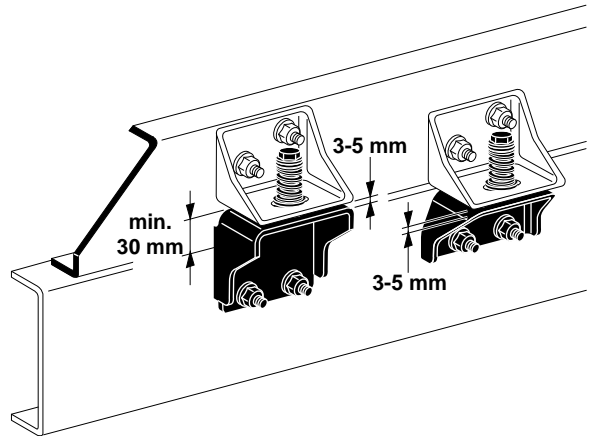

G000425

First and second attachment, LF and CF65 series

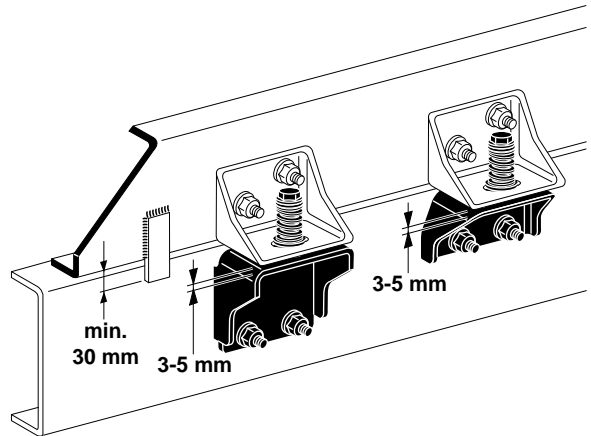

G000453

First and second attachment with restrainer plate , LF and CF65 series

Position of first attachment point (non-rigid) in relation to front axle centre line								
Vehicle type	Leaf-sprung front axle				Air-sprung front axle			
	Day cab		Sleeper cab		Day cab		Sleeper cab	
	LH side	RH side	LH side	RH side	LH side	RH side	LH side	RH side
FA LF45 7.5/12 tonnes	611 ⁽²⁾		1205	1198 ⁽¹⁾	-		-	
FA/N LF55 12/15 tonnes	620 ⁽²⁾		894		-		-	
FA LF55 18-19 tonnes	570 ⁽²⁾		844		-		-	
FA CF65	851 ⁽²⁾		1040		-		-	
FA CF75-85	619 ⁽³⁾		1072		562		922	
FA XF	-		1072		-		-	
FAS/R/N CF75-85	562 ⁽²⁾		922		562		922	
FAN XF	-		922		-		922	
FAG CF75-85	619 ⁽³⁾		1072		-		-	
FAT CF75-85	571 ⁽²⁾		922		-		-	
FAT XF	-		922		-		-	
FAD XF	-		1015		-		-	
FAD CF75	619 ⁽²⁾		1015		-		-	
FAC/D/X CF85	619 ⁽²⁾		1015		-		-	
FAK XF	-		1067	1048	-		-	

(1) Distance is valid for chassis equipped with 125 Ah batteries. If 175 Ah batteries are installed then the distance is 1281 mm.

(2) If a vertical exhaust system (pipe) is fitted then use the values of the sleeper cab situation.

(3) If a vertical exhaust system (pipe) is fitted then the distance is 677mm.

3.4 TYPE OF SUPERSTRUCTURE/ BAM MATRIX

The following overview shows the attachment method specified by DAF for each of the most common types of superstructure. The aim has been to achieve an optimum compromise between chassis strength and rigidity for specific superstructures on the one hand (strength) and maximum flexibility for vehicle comfort on the other hand. Consult DAF for any superstructure variants not mentioned in this matrix.

BODYBUILDERS' GUIDELINES

General information on superstructures

3

BAM overview on the basis of types of superstructure						
TYPE OF SUPERSTRUCTURE	BAM 1	BAM 2	BAM 3a ⁽¹⁾	BAM 3b ⁽¹⁾	BAM 4	BAM 5
Fixed body	■					
Demountable body with sub-frame	■					
(High-)volume body	■		■			
Body with tail lift				■		
Tanker with sub-frame	■					
Tanker with console attachment						■
Compactor refuse collector	■		■			■
Refuse collector with rotating drum					■	
Road sweeper	■		■			
Gully emptier	■		■			
Tipper with front-end ram			■			
Tipper with central ram			■			
Three-way tipper			■		■	
Tipping demountable body					■	
Loading arm system					■	
Concrete mixer and concrete pump					■	
Vehicle loading crane immediately behind the cab		■			■	
Vehicle loading crane at rear end of chassis			■		■	
Recovery vehicle					■	
Hydraulic platform (dependent on type)	■				■	
Fork-lift truck carrier				■		
Fire-fighting vehicle (water tender)	■					■

(1) For LF and CF65 chassis use BAM3 instead of BAM3a or BAM3b.



WARNING! Ensure that the operation of the moving parts on the chassis cannot be impeded by the attachments. Furthermore, all vehicle components should remain easily accessible for maintenance and repair.

3.5 BAM INSTRUCTIONS, GENERAL

For correct sub-frame attachment, the following bodying instructions should be adhered to:

BODYBUILDERS' GUIDELINES

General information on superstructures

- A. The minimum numbers of fasteners stated on the next pages should be strictly adhered to. The fasteners should be evenly spaced over the parts I, II and III indicated in the drawings on the next pages. The length dimensions of the parts I, II and III are indicative values.
- B. The numbers indicated always apply to only one chassis member.
- C. When attachment methods **BAM 1, 2, 3a, 3b and 4** are applied, the distance between one attachment point and the next must never be more than 1200 mm. The only exception to this rule is BAM 2, where it is impossible to fit tie rods between the spring brackets of the rear axle!
- D. The sub-frame should extend forwards as far as possible and it should be attached to the first attachment point.
- E. The front of the body must not protrude more than 300 mm from the first attachment point.
- F. The matching attachment points in the LH and RH side members must not be more than 300 mm backwards or forwards in relation to each other.
- G. The rear end of the body must not protrude more than 450 mm from the rearmost attachment point.
- H. Sometimes two figures are given for the number of attachments. In such cases, the number depends on the pre-drilled holes and/or the rear overhang selected, and should be in accordance with the instructions given above.
- I. Always consult DAF when, applying one of the BAM's detailed on the next pages, you are unable to comply with the above instructions.
- J. On LF, CF and XF vehicles, the hole patterns for BAM 1 and BAM 3 are partly provided. In some cases, these holes can of course also be used for BAM 4 and/or BAM 5.
- K. The chassis frames of all vehicle series (with the exception of the FA LF45) are tapered at the cab rear wall. The sub-frame used should follow the lines of the chassis frame.
- L. On some vehicles the front body attachment plates coincide with the vehicle component attachment brackets. It is allowed to fit a body attachment plate with a thickness of at most 8 mm between side member and attachment brackets. It should however be ensured that the attachment and the position of the component on the chassis are equivalent to the original construction.

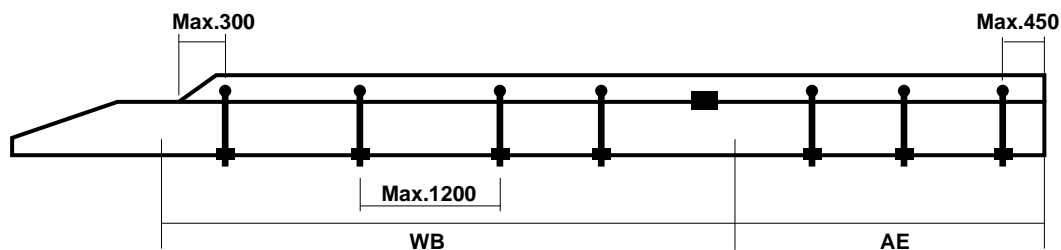

CF75-85 and XF Series

96120404-322

BODYBUILDERS' GUIDELINES

General information on superstructures

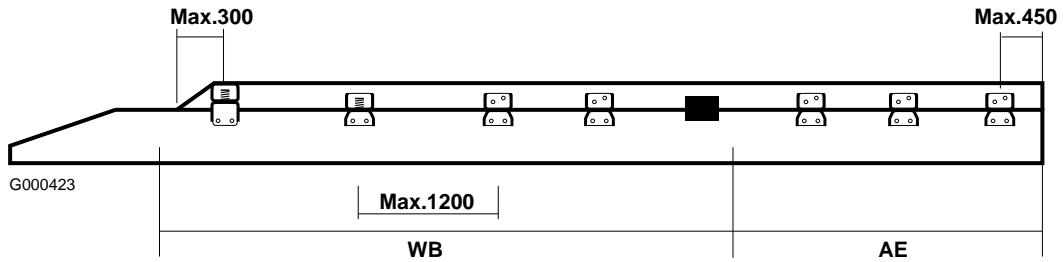

LF and CF65 Series



3

3.6 FA LF45

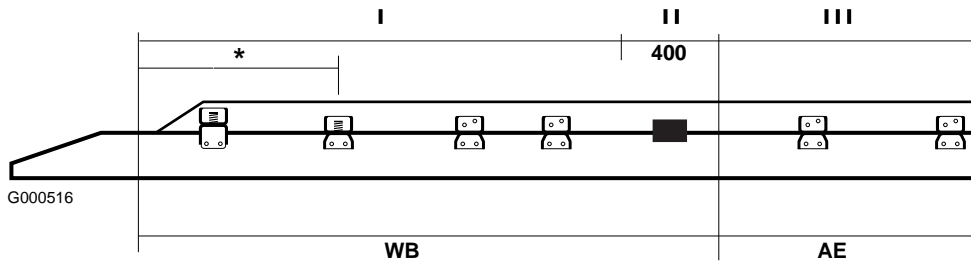
FA LF45, BAM 1.

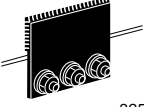

* See 3.3: "First attachment point".

Wheelbase [m]	Rear axle suspension	I (1)	II	III
		 G000426	 -325	 G000426
≤ 3.55	Parabolic + air	3	1	2
≤ 4.30	Parabolic + air	4	1	3
≤ 5.00	Parabolic + air	5	1	4
≤ 5.40	Parabolic + air	5	1	3

(1) The first and second consoles always are spring loaded; see 3.3: "First attachment point"



NOTE: BAM 1 chassis mounted brackets (illustrated black in table) can be ordered ex-factory with selcode: 0126.
For part numbers of consoles / brackets that are available via DAF After Sales see chapter 13.1: "Mountings".

BODYBUILDERS' GUIDELINES

General information on superstructures

FA LF45, BAM 2.

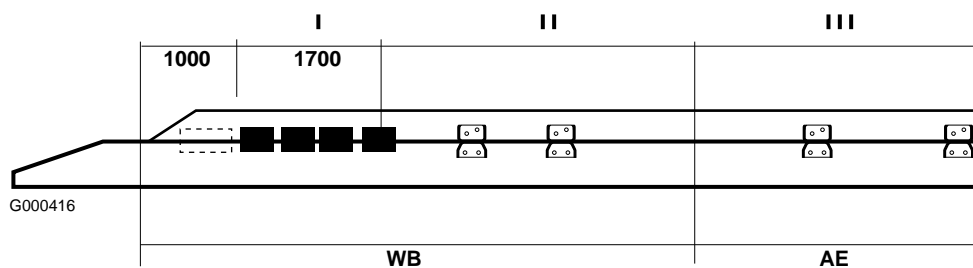

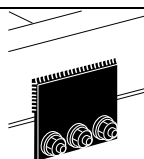
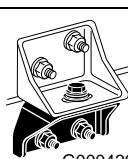
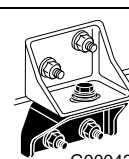
Wheelbase [m]	Rear axle suspension	I	II	III
		 -325	 G000426	 G000426
≤ 3.55	Parabolic + air	2	1	2
≤ 4.30	Parabolic + air	2	2	3
≤ 5.00	Parabolic + air	2	3	4
≤ 5.40	Parabolic + air	2	3	3

3

BODYBUILDERS' GUIDELINES

General information on superstructures

FA LF45, BAM 3.

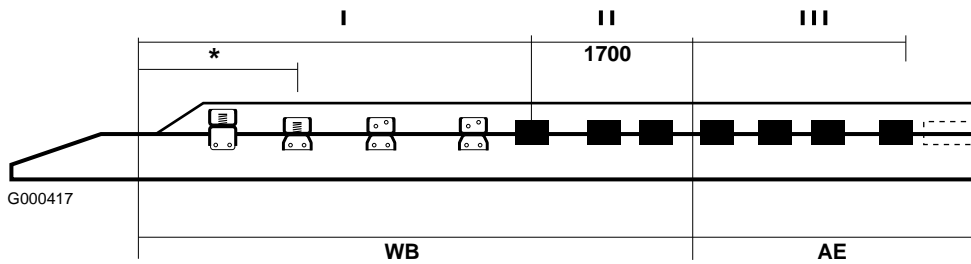

* See 3.3: "First attachment point".

3

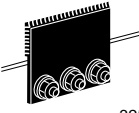
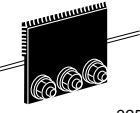
Wheelbase [m]	Rear axle suspension	I (1)	II	III
		 G000426	 -325	 -325
≤ 3.00	Asymmetric	1	3	1
≤ 3.15	Parabolic	1	3	2
≤ 3.15	Air	2	2	2
≤ 3.55	Parabolic + air	2	2	2
≤ 3.90	Parabolic + air	2	3	3
≤ 4.30	Parabolic + air	3	2	3
≤ 4.65	Parabolic + air	4	2	4
≤ 5.00	Parabolic + air	3	3	4
≤ 5.40	Parabolic + air	4	2	3

(1) First and second consoles are always spring loaded, see 3.3: "First attachment point"



NOTE: BAM 3 chassis mounted brackets (illustrated black in table) can be ordered ex-factory via POV request. For part numbers of consoles / brackets that are available via DAF After Sales see chapter 13.1: "Mountings".

BODYBUILDERS' GUIDELINES

General information on superstructures

FA LF45, BAM 4.

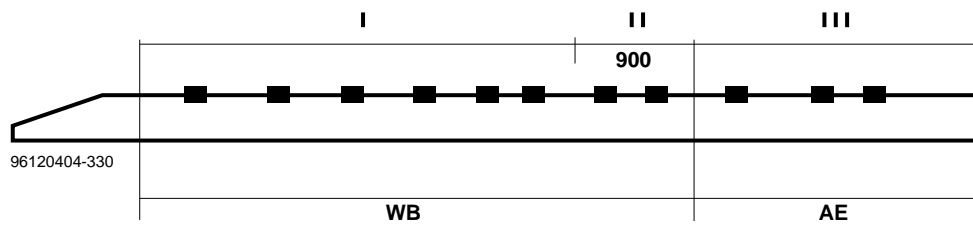

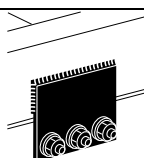
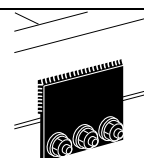
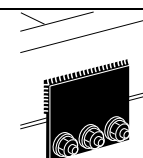
Wheelbase [m]	Rear axle suspension	I	II	III
		 -325	 -325	 -325
≤ 3.00	Asymmetric	2	2	1
≤ 3.15	Parabolic + air	2	2	2
≤ 3.55	Parabolic + air	3	1	2
≤ 4.30	Parabolic + air	4	1	3
≤ 5.00	Parabolic + air	5	1	4
≤ 5.40	Parabolic + air	5	1	3

FA LF45, BAM 5.

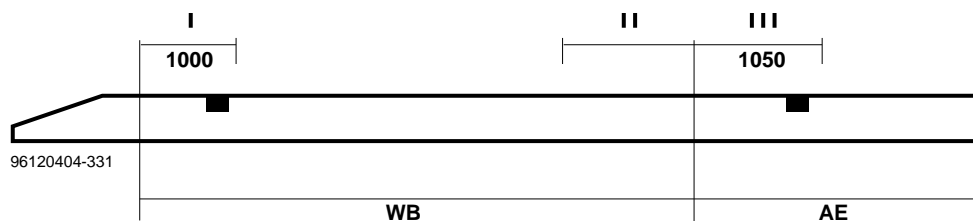

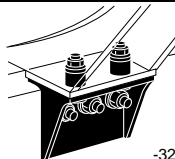
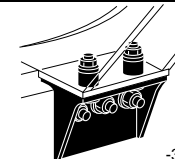
Wheelbase [m]	Rear axle suspension	I	II	III
		 -326		 -326
≤ 3.55	Parabolic + air	1	-	1

3

BODYBUILDERS' GUIDELINES



General information on superstructures

3.7 FA LF55

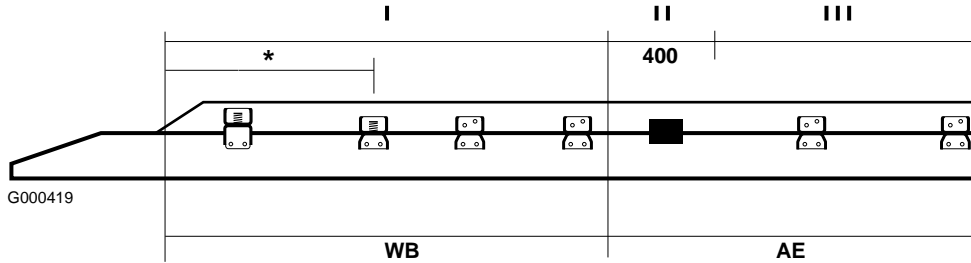
FA LF55 13-15T, BAM 1.

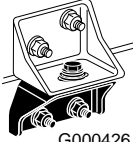
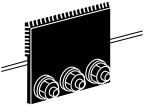

* See 3.3: "First attachment point"

Wheelbase [m]	Rear axle suspension	I (1)	II	III
		 G000426	 -325	 G000426
≤ 3.50	Parabolic + air	3	1	2
≤ 4.20	Parabolic + air	4	1	3
≤ 4.80	Parabolic + air	5	1	3
≤ 5.90	Parabolic + air	6	1	4
≤ 6.30	Parabolic + air	7	1	4

(1) First and second consoles are always spring loaded, see 3.3: "First attachment point"



NOTE: BAM 1 chassis mounted brackets (illustrated black in table) can be ordered ex-factory with selcode: 0126.

For part numbers of consoles / brackets that are available via DAF After Sales see chapter 13.1: "Mountings".

BODYBUILDERS' GUIDELINES

General information on superstructures

FA LF55 13-15T, BAM 2.

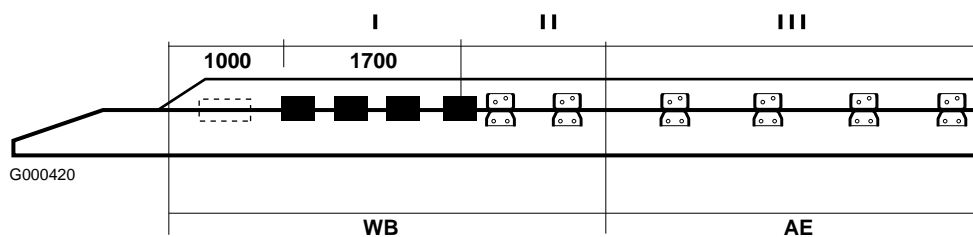

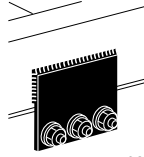
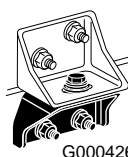
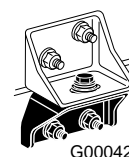
Wheelbase [m]	Rear axle suspension	I	II	III
		 -325	 G000426	 G000426
≤ 3.50	Parabolic + air	2	1	2
≤ 4.20	Parabolic + air	2	2	3
≤ 4.80	Parabolic + air	2	3	3
≤ 5.90	Parabolic + air	2	4	4
≤ 6.30	Parabolic + air	2	5	4

3

BODYBUILDERS' GUIDELINES

General information on superstructures

FA LF55 13-15T, BAM 3.

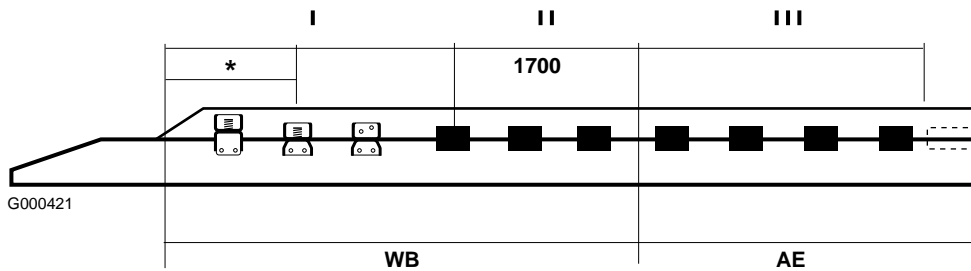

* See 3.3: "First attachment point".

3

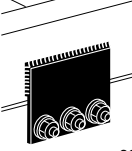
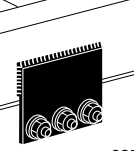
Wheelbase [m]	Rear axle suspension	I (1)	II	III
				
≤ 3.50	Parabolic + air	2	2	2
≤ 3.80	Parabolic + air	2	3	3
≤ 4.20	parabolic + air	3	2	3
≤ 4.50	Parabolic + air	3	3	3
≤ 4.80	Parabolic + air	4	2	3
≤ 5.35	Parabolic + air	5	2	4
≤ 5.90	Parabolic + air	5	2	4
≤ 6.30	Parabolic + air	6	2	4

(1) First and second consoles are always spring loaded, see 3.3: "First attachment point"



NOTE: BAM 3 chassis mounted brackets (illustrated black in table) can be ordered ex-factory via POV request. For part numbers of consoles / brackets that are available via DAF After Sales see chapter 13.1: "Mountings".

BODYBUILDERS' GUIDELINES

General information on superstructures

FA LF55 13-15T, BAM 4.

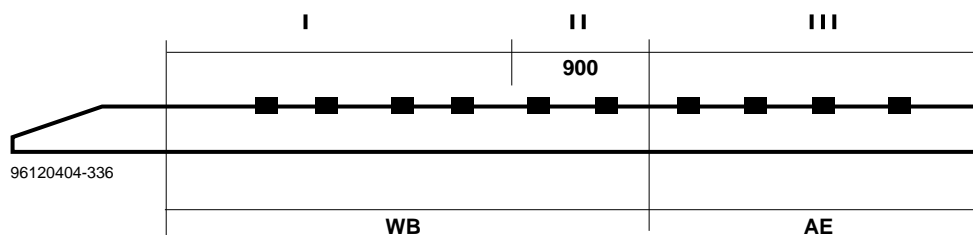

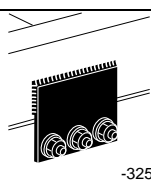
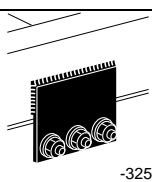
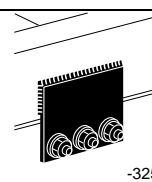
Wheelbase [m]	Rear axle suspension	I	II	III
				
≤ 3.50	Parabolic + air	3	1	2
≤ 3.80	Parabolic	3	2	3
≤ 3.80	air	4	1	3
≤ 4.20	Parabolic + air	4	1	3
≤ 4.80	Parabolic + air	5	1	3
≤ 5.90	Parabolic + air	6	1	4
≤ 6.30	Parabolic + air	7	1	4

3

FA LF55 13-15T, BAM 5.

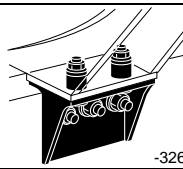
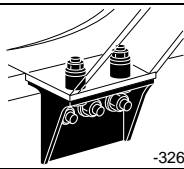
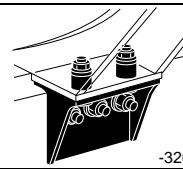

Wheelbase [m]	Rear axle suspension	I	II	III
				
All	Parabolic + air	1	1	1

BODYBUILDERS' GUIDELINES



General information on superstructures

3.8 FA LF55 18T

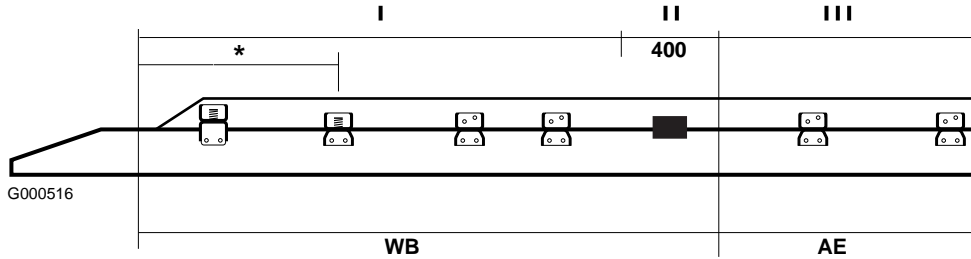
FA LF55 18T, BAM 1.

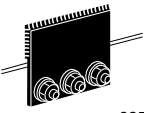

* See 3.3: "First attachment point".

Wheelbase [m]	Rear axle suspension	I (1)	II	III
		 G000426	 -325	 G000426
≤ 3.45	Parabolic + air	3	1	2
≤ 3.75	Parabolic + air	4	1	2
≤ 4.15	Parabolic + air	4	1	3
≤ 4.75	Parabolic + air	5	1	3
≤ 5.80	Parabolic + air	6	1	3
≤ 6.25	Parabolic + air	7	1	4

(1) First and second consoles are always spring loaded, see 3.3: "First attachment point"



NOTE: BAM 1 chassis mounted brackets (illustrated black in table) can be ordered ex-factory with selcode: 0126.

For part numbers of consoles / brackets that are available via DAF After Sales see chapter 13.1: "Mountings".

BODYBUILDERS' GUIDELINES

General information on superstructures

FA LF55 18T, BAM 2.

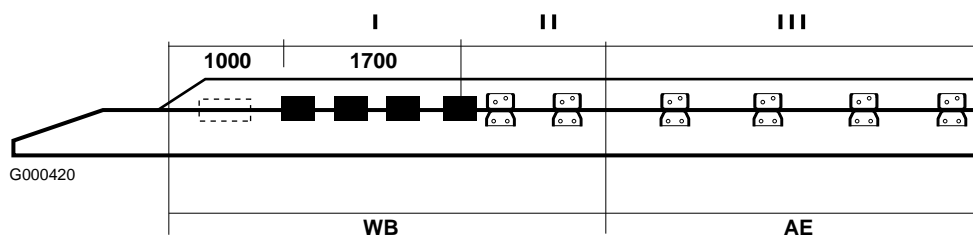

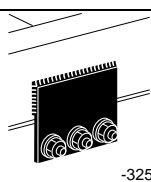
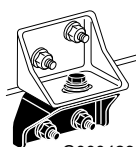
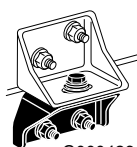
Wheelbase [m]	Rear axle suspension	I	II	III
		 -325	 G000426	 G000426
≤ 3.45	Parabolic + air	2	0	2
≤ 3.75	Parabolic + air	2	2	2
≤ 4.15	Parabolic + air	2	2	3
≤ 4.75	Parabolic + air	2	3	3
≤ 5.80	Parabolic + air	2	4	3
≤ 6.25	Parabolic + air	2	5	4

3

BODYBUILDERS' GUIDELINES

General information on superstructures

FA LF55 18T, BAM 4.

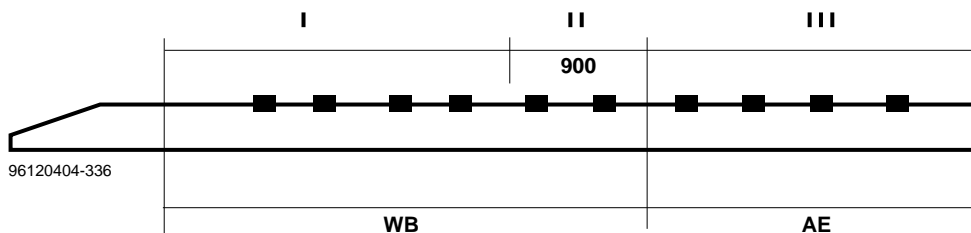

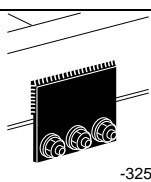
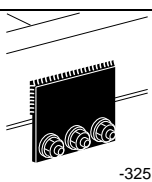
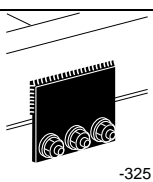
Wheelbase [m]	Rear axle suspension	I	II	III
		 -325	 -325	 -325
≤ 3.45	Parabolic + air	3	1	2
≤ 3.75	Parabolic	3	2	2
≤ 3.75	Air	4	1	2
≤ 4.15	Parabolic + air	4	1	3
≤ 4.75	Parabolic + air	5	1	3
≤ 5.25	Parabolic + air	6	1	3
≤ 5.85	Parabolic + air	7	1	4

3

FA LF55 18T, BAM 5.

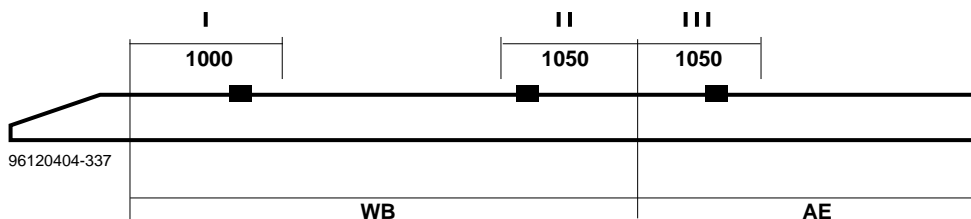

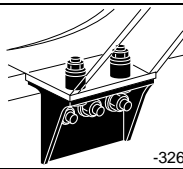
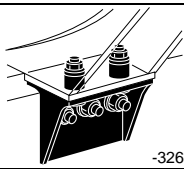
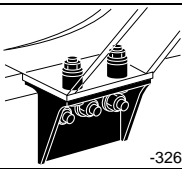
Wheelbase [m]	Rear axle suspension	I	II	III
		 -326	 -326	 -326
All	Parabolic + air	1	1	1

BODYBUILDERS' GUIDELINES



General information on superstructures

3.9 FA CF65

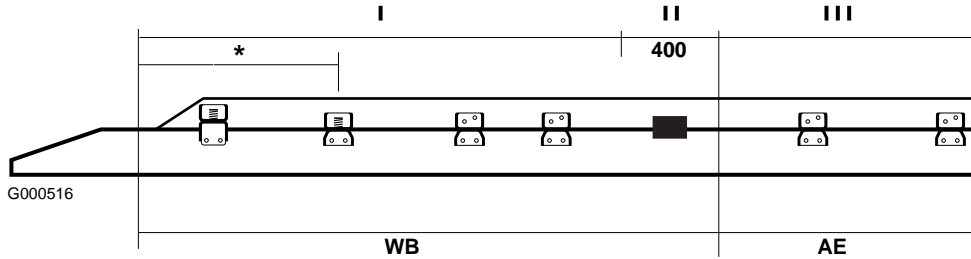
FA CF65, BAM 1.

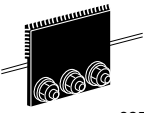

* See 3.3: "First attachment point".

Wheelbase [m]	Rear axle suspension	I (1)	II	III
		 G000426	 -325	 G000426
≤ 4.15	Parabolic + air	4	1	3
≤ 4.90	Parabolic + air	5	1	3
≤ 5.70	Parabolic + air	6	1	3/4
≤ 6.10	Parabolic + air	6	1	4
≤ 6.60	Parabolic + air	7	1	4
≤ 6.90	Parabolic + air	7	1	4/5
≤ 7.30	Parabolic + air	7	1	4

(1) First and second consoles are always spring loaded, see 3.3: "First attachment point"



NOTE: BAM 1 chassis mounted brackets (illustrated black in table) can be ordered ex-factory with selcode: 0126.

For part numbers of consoles / brackets that are available via DAF After Sales see chapter 13.1: "Mountings".

BODYBUILDERS' GUIDELINES

General information on superstructures

FA CF65, BAM 2.

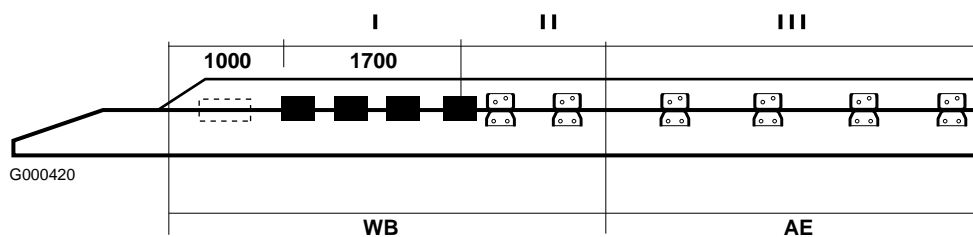

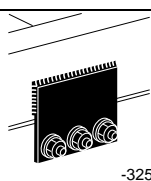
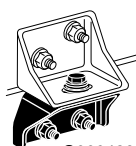
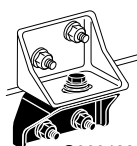
Wheelbase [m]	Rear axle suspension	I	II	III
		 -325	 G000426	 G000426
≤ 4.15	Parabolic + air	2	3	3
≤ 4.90	Parabolic + air	2	4	3
≤ 5.70	Parabolic + air	2	5	3/4
≤ 6.10	Parabolic + air	2	5	4
≤ 6.60	Parabolic + air	2	6	4
≤ 6.90	Parabolic + air	2	6	4/5
≤ 7.30	Parabolic + air	2	6	4

3

BODYBUILDERS' GUIDELINES

General information on superstructures

FA CF65, BAM 3.

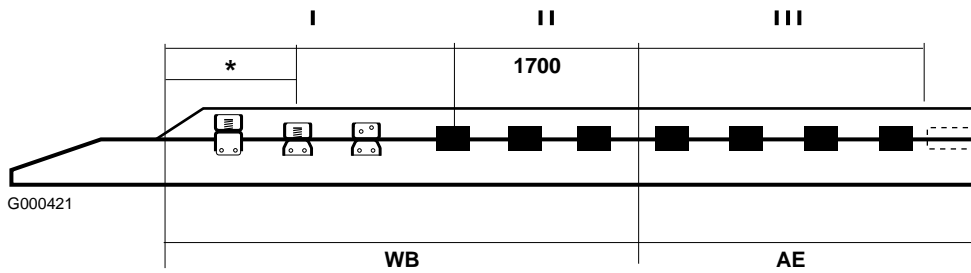

* See 3.3: "First attachment point".

3

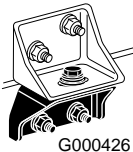
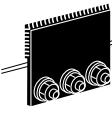
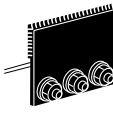
Wheelbase [m]	Rear axle suspension	I (1)	II	III
				
≤ 4.15	Parabolic + air	3	2	3
≤ 4.90	Parabolic + air	4	2	3
≤ 5.70	Parabolic + air	5	2	3/4
≤ 6.10	Parabolic + air	5	2	4
≤ 6.60	Parabolic + air	6	2	4
≤ 6.90	Parabolic + air	6	2	4/5
≤ 7.30	Parabolic + air	6	2	4

(1) First and second consoles are always spring loaded, see 3.3: "First attachment point"

BODYBUILDERS' GUIDELINES

General information on superstructures

FA CF65, BAM 4.

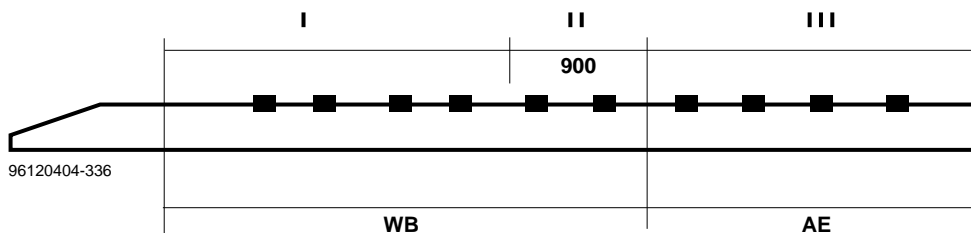

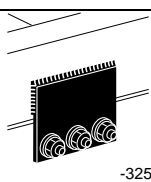
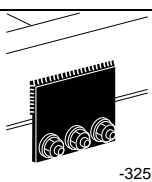
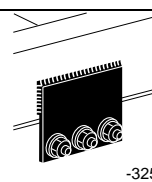
Wheelbase [m]	Rear axle suspension	I	II	III
		 -325	 -325	 -325
≤ 4.15	Parabolic + air	4	1	3
≤ 4.90	Parabolic + air	5	1	3
≤ 5.70	Parabolic + air	6	1	3/4
≤ 6.10	Parabolic + air	6	1	4
≤ 6.60	Parabolic + air	7	1	4
≤ 6.90	Parabolic + air	7	1	4/5
≤ 7.30	Parabolic + air	7	1	4

3

FA CF65, BAM 5.

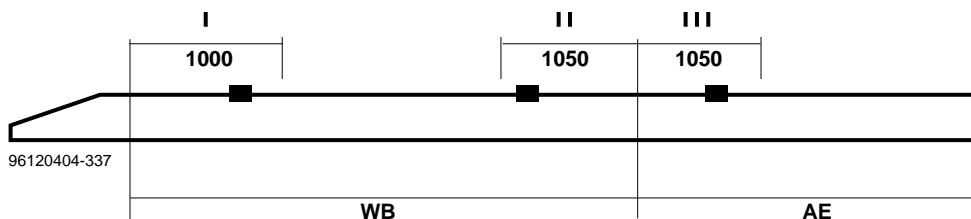

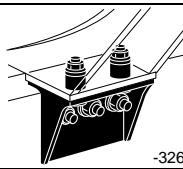
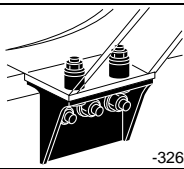
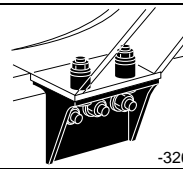
Wheelbase [m]	Rear axle suspension	I	II	III
		 -326	 -326	 -326
All	Parabolic + air	1	2	1

BODYBUILDERS' GUIDELINES

General information on superstructures

3.10 FA CF AND XF

FA CF75-85 and XF, BAM1.

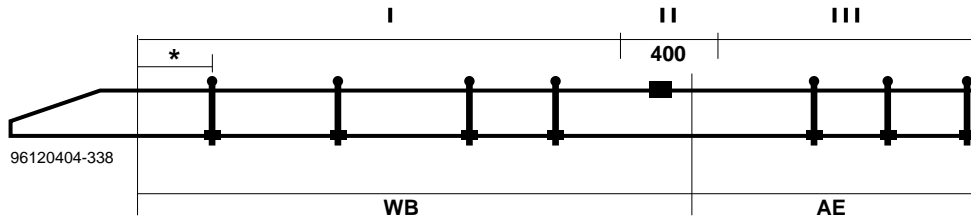

* See 3.3: "First attachment point".

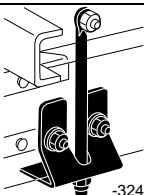
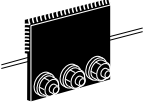
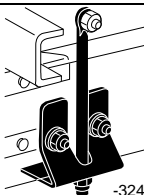
Wheelbase [m]	Rear axle suspension	I	II	III
		 -324	 -325	 -324
≤ 3.80	Parabolic	4	1	2
≤ 4.90	Parabolic + air	5	1	2
≤ 6.10	Parabolic + air	6	1	2/3
≤ 6.90	Parabolic + air	6 / 7	1	4
≤ 7.50	Parabolic + air	7	1	4

FA CF75-85 and XF, BAM2.

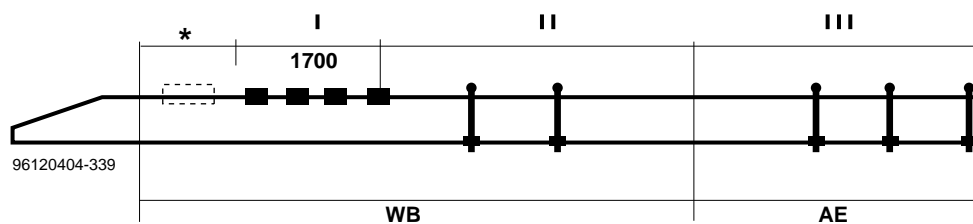

* See 3.3: "First attachment point".

Wheelbase [m]	Rear axle suspension	I	II	III
≤ 4.50	Parabolic + air	4	1	2
≤ 5.50	Parabolic + air	4	2	2/3
≤ 6.10	Parabolic + air	4	3	2/3
≤ 6.90	Parabolic + air	4 / 5	4	4
≤ 7.50	Parabolic + air	5	4	4

FA CF75-85 and XF, BAM 3a.

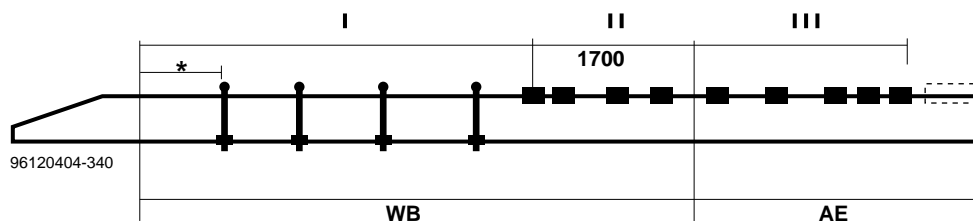

* See 3.3: "First attachment point".

Wheelbase [m]	Rear axle suspension	I	II	III
≤ 4.20	Parabolic + air	3	3	4
≤ 4.90	Parabolic + air	3	4	4
≤ 6.90	Parabolic + air	4	4	5
≤ 7.50	Parabolic + air	4	4	5

BODYBUILDERS' GUIDELINES

General information on superstructures

FA CF75-85 and XF, BAM 3b.

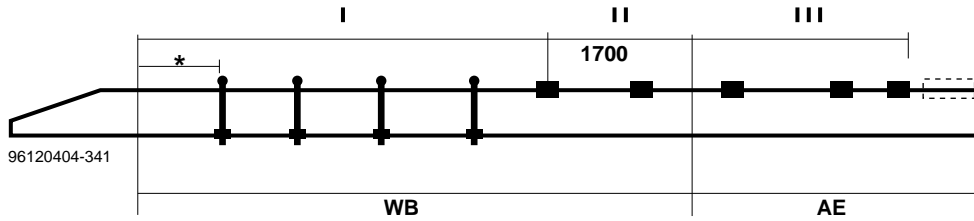

* See 3.3: "First attachment point".

3

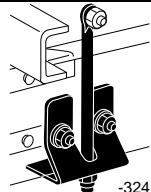
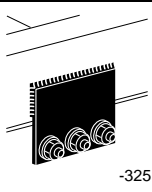
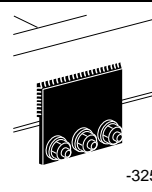
Wheelbase [m]	Rear axle suspension	I	II	III
				
≤ 4.20	Parabolic + air	3	1	2
≤ 4.90	Parabolic + air	3	2	2
≤ 6.90	Parabolic + air	4	2	3
≤ 7.50	Parabolic + air	4	2	4

FA CF75-85 and XF, BAM 4.

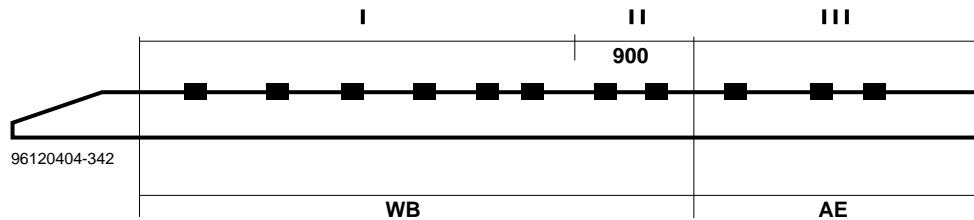

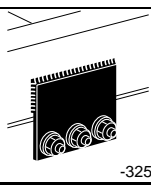
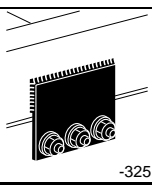
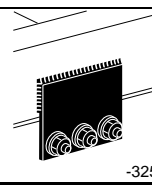
Wheelbase [m]	Rear axle suspension	I	II	III
				
≤ 4.20	Parabolic + air	6	1	3
≤ 4.90	Parabolic + air	6	1	3
≤ 6.10	Parabolic + air	6	1	3
≤ 6.90	Parabolic + air	6	1	4
≤ 7.50	Parabolic + air	6	1	4

FA CF75-85 and XF, BAM 5.

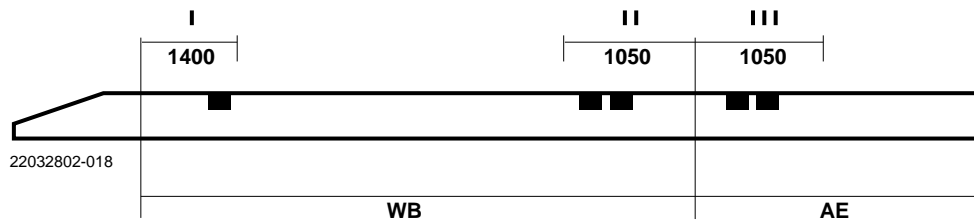

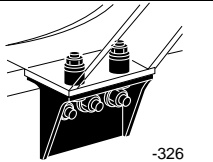
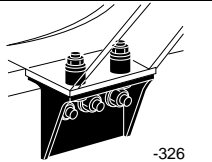
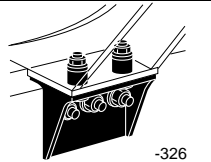
Wheelbase [m]	Rear axle suspension	I	II	III
				
All	Parabolic + air	1	2	1

3

3.11 FAR/FAS CF AND XF

FAR/FAS CF75-85 and XF, BAM 1.

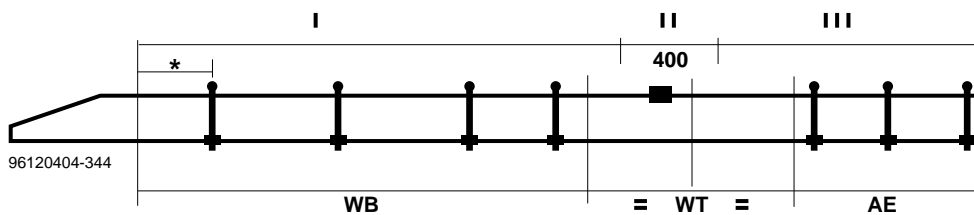

* See 3.3: "First attachment point".

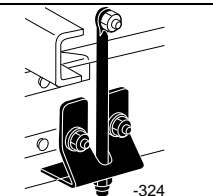
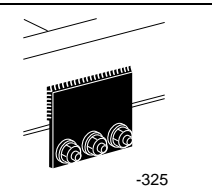
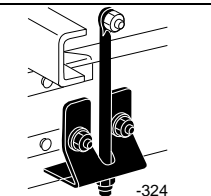
Wheelbase [m]	Rear axle suspension	I	II	III
				
≤ 3.80	Parabolic + air	3	1	2/3
≤ 4.80	Parabolic + air	5	1	3
≤ 5.30	Parabolic + air	6	1	4
≤ 6.10	Parabolic + air	7	1	4

BODYBUILDERS' GUIDELINES

General information on superstructures

FAR/FAS CF75-85 and XF, BAM 2.

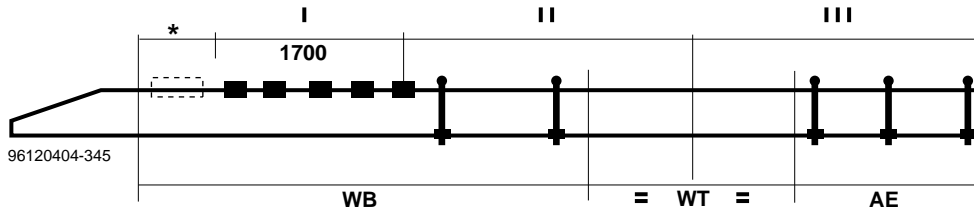

* See 3.3: "First attachment point".

3

Wheelbase [m]	Rear axle suspension	I	II	III
≤ 3.80	Parabolic + air	5	1	2/3
≤ 4.80	Parabolic + air	5	3	3
≤ 5.30	Parabolic + air	5	3	4
≤ 6.10	Parabolic + air	5	4	4

FAR/FAS CF75-85 and XF, BAM 3a.

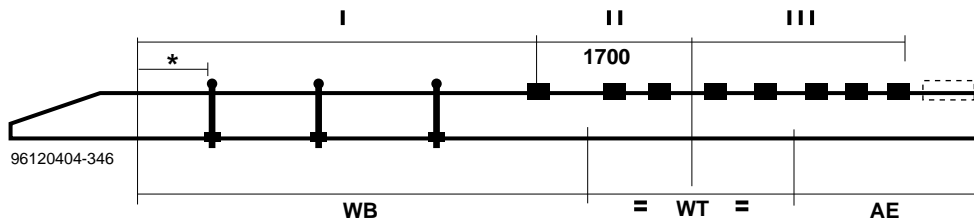

* See 3.3: "First attachment point".

Wheelbase [m]	Rear axle suspension	I	II	III
≤ 3.80	Parabolic + air	2	5	3
≤ 4.80	Parabolic + air	4	5	4
≤ 5.30	Parabolic + air	4	5	4
≤ 6.10	Parabolic + air	5	5	4

FAR/FAS CF75-85 and XF, BAM 3b.

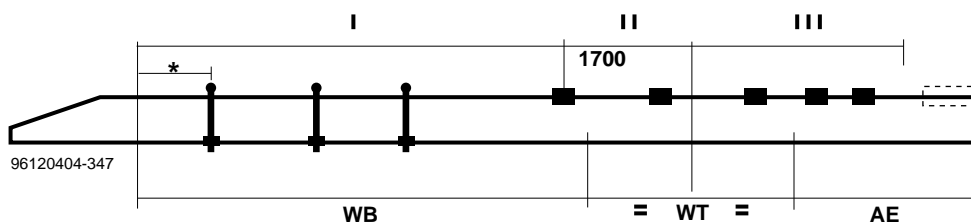

* See 3.3: "First attachment point".

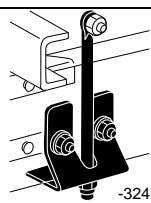
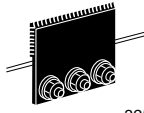
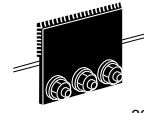
Wheelbase [m]	Rear axle suspension	I	II	III
				
≤ 3.80	Parabolic + air	2	2	2
≤ 4.80	Parabolic + air	4	2	2
≤ 5.30	Parabolic + air	4	2	3
≤ 6.10	Parabolic + air	5	2	3

FAR/FAS CF75-85 and XF, BAM 4.

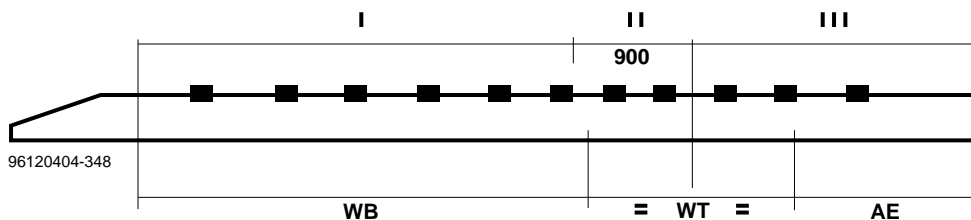

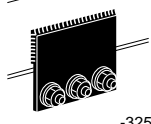
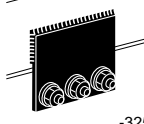
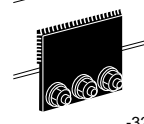
Wheelbase [m]	Rear axle suspension	I	II	III
				
≤ 3.80	Parabolic + air	6	3	3
≤ 4.80	Parabolic + air	7	3	4
≤ 5.30	Parabolic + air	8	3	4
≤ 6.10	Parabolic + air	9	3	4

BODYBUILDERS' GUIDELINES

General information on superstructures

FAR/FAS CF75-85 and XF, BAM 5.

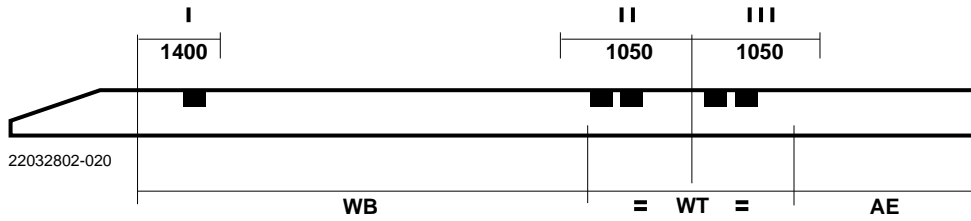

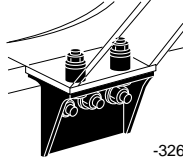
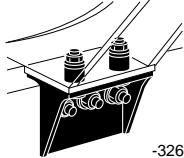
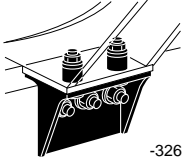
Wheelbase [m]	Rear axle suspension	I	II	III
		 -326	 -326	 -326
All	Parabolic + air	1	2	2

3.12 FAG CF

FAG CF75-85, BAM 1.

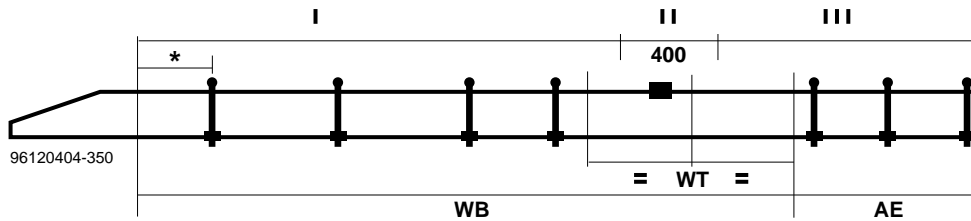

* See 3.3: "First attachment point".

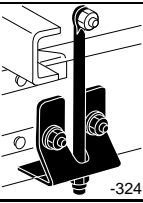
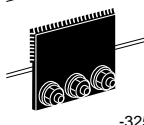
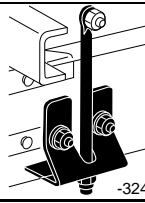
Wheelbase [m]	Rear axle suspension	I	II	III
		 -324	 -325	 -324
≤ 4.80	Parabolic + air	4	1	1/2
≤ 5.35	Parabolic + air	5	1	3
≤ 5.90	Parabolic + air	6	1	3
≤ 6.60	Parabolic + air	6	1	3

FAG CF75-85, BAM 2.

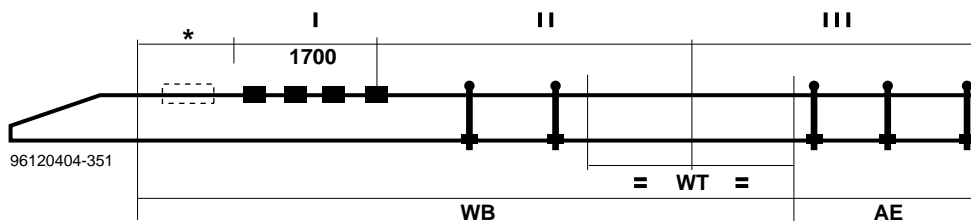

* See 3.3: "First attachment point".

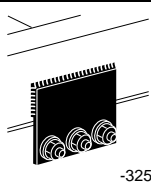
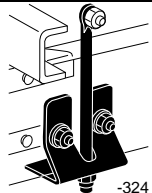
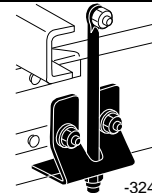
Wheelbase [m]	Rear axle suspension	I	II	III
				
≤ 4.80	Parabolic + air	4	2	2
≤ 5.35	Parabolic + air	4	3	3
≤ 5.90	Parabolic + air	4	3	3
≤ 6.60	Parabolic + air	4	4	3

FAG CF75-85, BAM 3a.

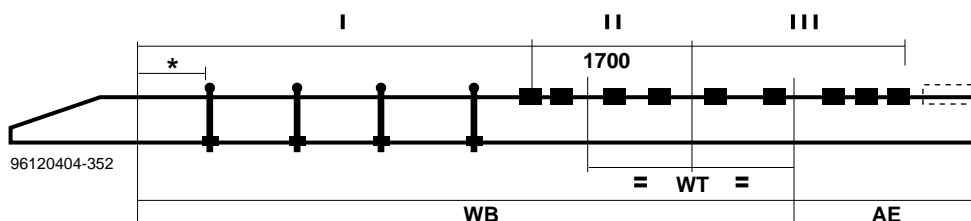

* See 3.3: "First attachment point".

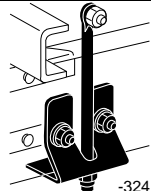
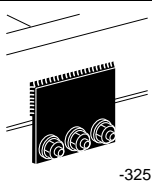
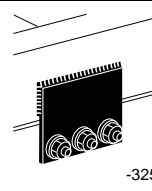
Wheelbase [m]	Rear axle suspension	I	II	III
				
≤ 4.80	Parabolic + air	3	4	4
≤ 5.35	Parabolic + air	4	4	4
≤ 5.90	Parabolic + air	5	4	4
≤ 6.60	Parabolic + air	5	4	5

BODYBUILDERS' GUIDELINES

General information on superstructures

FAG CF75-85, BAM 3b.

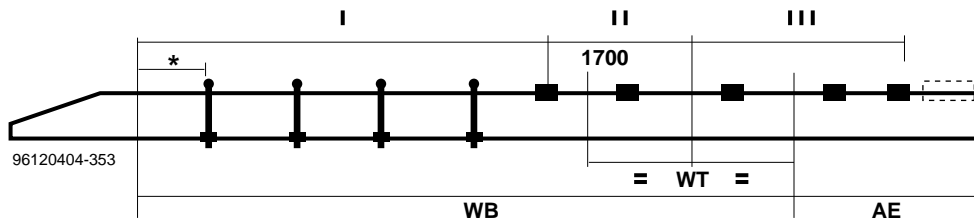

* See 3.3: "First attachment point".

3

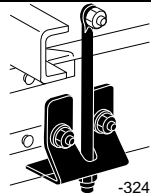
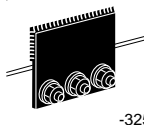
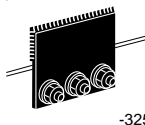
Wheelbase [m]	Rear axle suspension	I	II	III
				
≤ 4.80	Parabolic + air	3	2	2
≤ 5.35	Parabolic + air	4	2	2
≤ 5.90	Parabolic + air	5	2	2
≤ 6.60	Parabolic + air	5	3	3

FAG CF75-85, BAM 4.

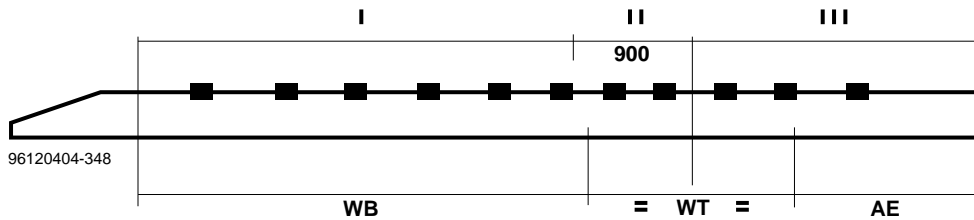

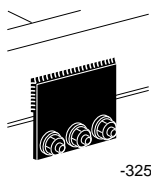
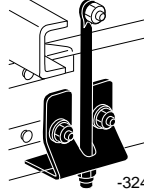
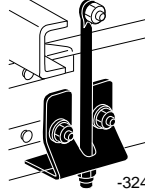
Wheelbase [m]	Rear axle suspension	I	II	III
				
≤ 4.80	Parabolic + air	5	4	3
≤ 5.35	Parabolic + air	6	4	4
≤ 5.90	Parabolic + air	7	4	4
≤ 6.60	Parabolic + air	8	4	4

FAG CF75-85, BAM 5.

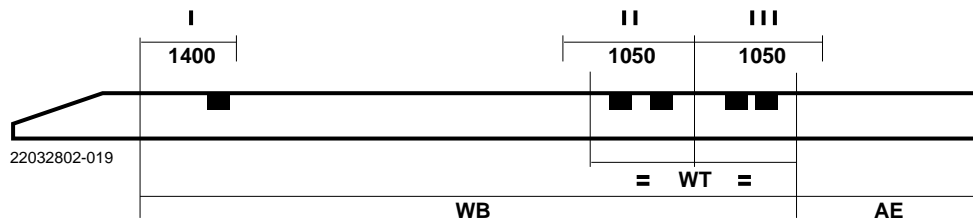

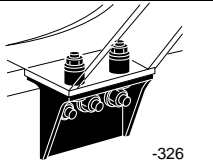
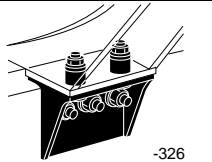
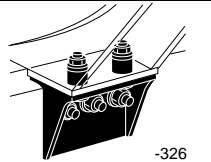
Wheelbase [m]	Rear axle suspension	I	II	III
		 -326	 -326	 -326
All	Parabolic + air	1	2	2

3

3.13 FAN LF

FAN LF55, BAM1.

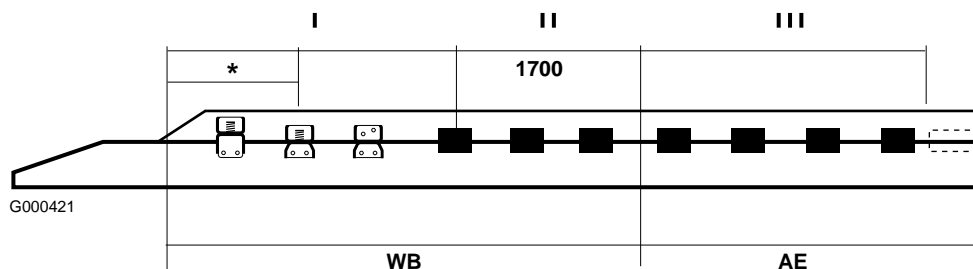

* See 3.3: "First attachment point".

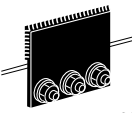
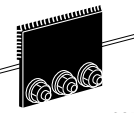
Wheelbase [m]	Rear axle suspension	I (1)	II	III
		 G000426	 -325	 -325
≤ 4.20	air	4	1	4
≤ 4.50	air	5	1	4
≤ 4.80	air	5	1	5
≤ 5.30	air	6	1	5

(1) First and second consoles are always spring loaded, see 3.3: "First attachment point"

BODYBUILDERS' GUIDELINES

General information on superstructures

FAN LF55, BAM 2.

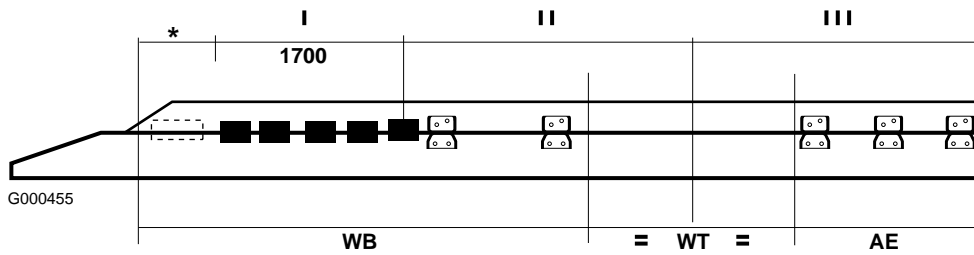

* See 3.3: "First attachment point".

3

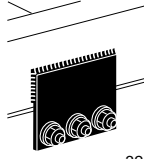
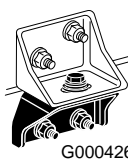
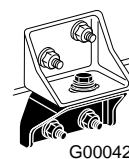
Wheelbase [m]	Rear axle suspension	I (1)	II	III
				
≤ 4.20	air	2	2	4
≤ 4.50	air	2	3	4
≤ 4.80	air	2	3	5
≤ 5.30	air	2	4	5

(1) first and second consoles are always spring loaded, see 3.3: "First attachment point"

BODYBUILDERS' GUIDELINES

General information on superstructures

FAN LF55, BAM 3.

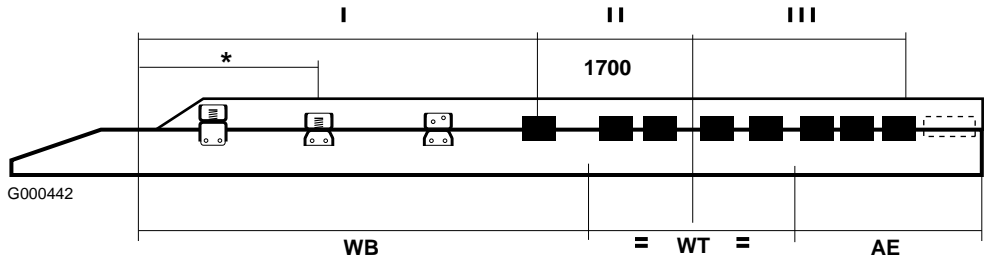

* See 3.3: "First attachment point".

3

Wheelbase [m]	Rear axle suspension	I (1)	II	III
≤ 3.80	air	2	3	4
≤ 4.20	air	3	2	4
≤ 4.50	air	3	3	4
≤ 4.80	air	4	2	5
≤ 5.35	air	5	2	5

(1) First and second consoles are always spring loaded, see 3.3: "First attachment point"

FAN LF55, BAM 4.

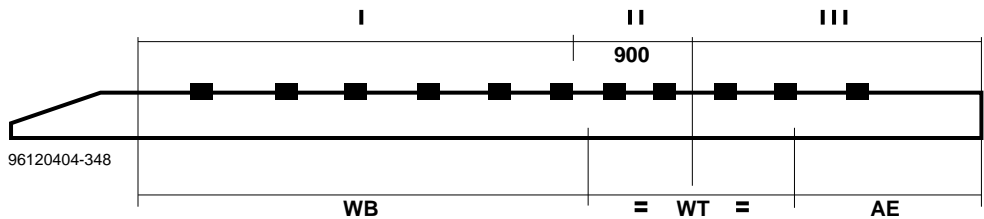

Wheelbase [m]	Rear axle suspension	I	II	III
≤ 4.20	air	4	1	4
≤ 4.50	air	5	1	4
≤ 4.80	air	5	1	5
≤ 5.30	air	6	1	5

BODYBUILDERS' GUIDELINES

General information on superstructures

FAN LF55, BAM 5.

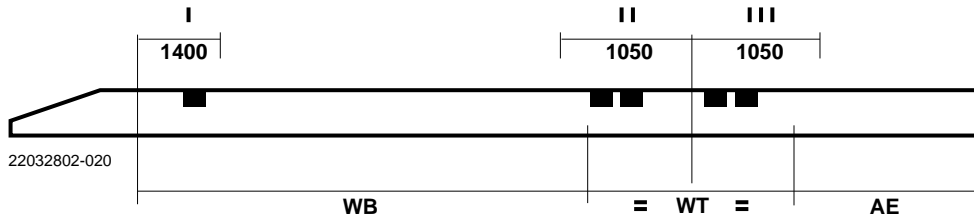

Wheelbase [m]	Rear axle suspension	I	II	III
All	air	1	2	2

3.14 FAN CF AND XF

FAN CF75-85 and XF, BAM1.

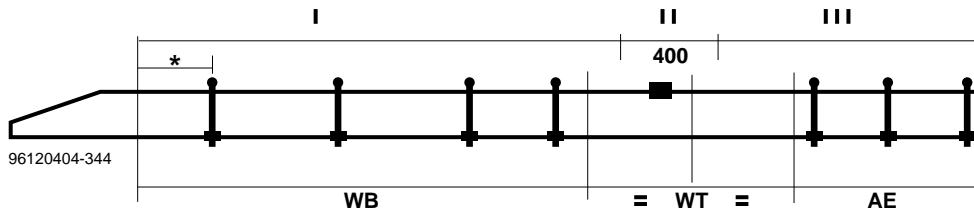

* See 3.3: "First attachment point".

Wheelbase [m]	Rear axle suspension	I	II	III
≤ 4.20	air	4	1	3
≤ 4.40	air	4	1	3
≤ 4.80	air	5	1	3
≤ 6.10	air	7	1	4
≤ 6.65	air	8	1	4

BODYBUILDERS' GUIDELINES

General information on superstructures

FAN CF75-85 and XF, BAM 2.

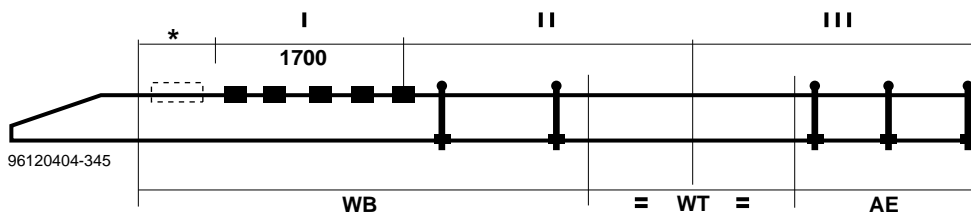

* See 3.3: "First attachment point".

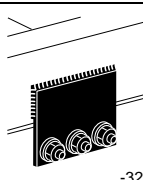
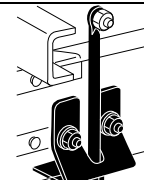
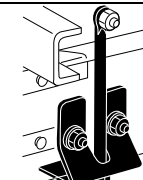
Wheelbase [m]	Rear axle suspension	I	II	III
		 -325	 -324	 -324
≤ 4.20	air	5	2	3
≤ 4.40	air	5	3	3
≤ 4.80	air	5	3	3
≤ 6.10	air	5	4	4
≤ 6.65	air	5	5	4

3

FAN CF75-85 and XF, BAM 3a.

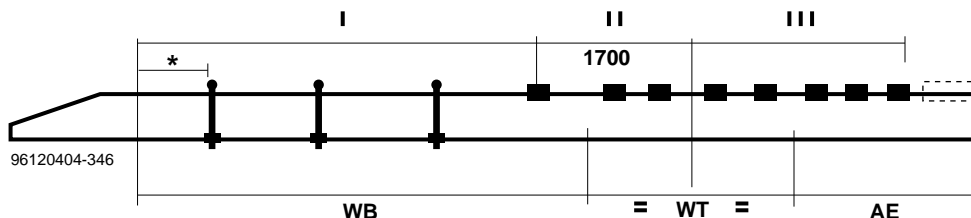

* See 3.3: "First attachment point".

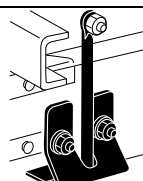
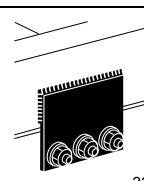
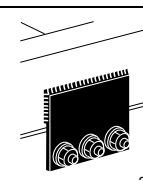
Wheelbase [m]	Rear axle suspension	I	II	III
		 -324	 -325	 -325
≤ 4.20	air	3	4	3
≤ 4.40	air	3	4	3
≤ 4.80	air	4	4	4
≤ 6.10	air	5	4	4
≤ 6.65	air	6	4	5

BODYBUILDERS' GUIDELINES

General information on superstructures

FAN CF75-85 and XF, BAM 3b.

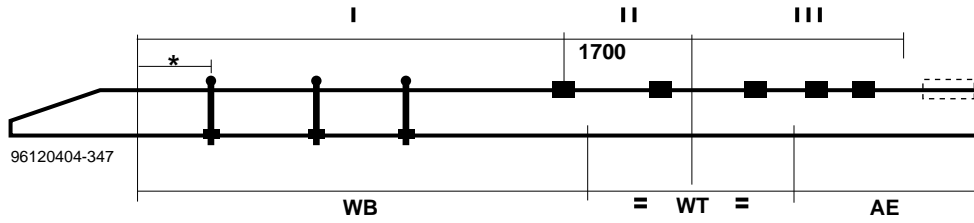

* See 3.3: "First attachment point".

3

Wheelbase [m]	Rear axle suspension	I	II	III
≤ 4.20	air	3	2	2
≤ 4.40	air	3	2	2
≤ 4.80	air	4	2	2
≤ 6.10	air	5	2	2
≤ 6.65	air	6	2	3

FAN CF75-85 and XF, BAM 4.

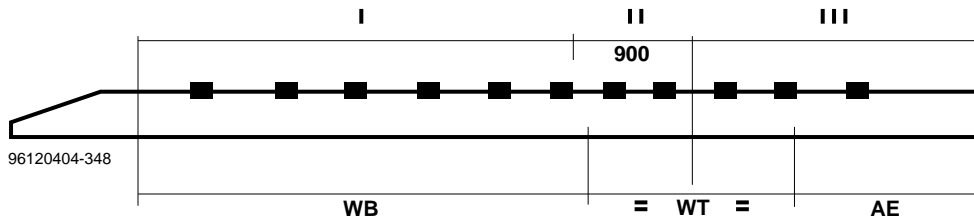

Wheelbase [m]	Rear axle suspension	I	II	III
≤ 4.20	air	6	3	2
≤ 4.40	air	6/7	3	3
≤ 4.80	air	7	3	4
≤ 6.10	air	8	3	4
≤ 6.65	air	8	3	4

FAN CF75-85 and XF, BAM 5.

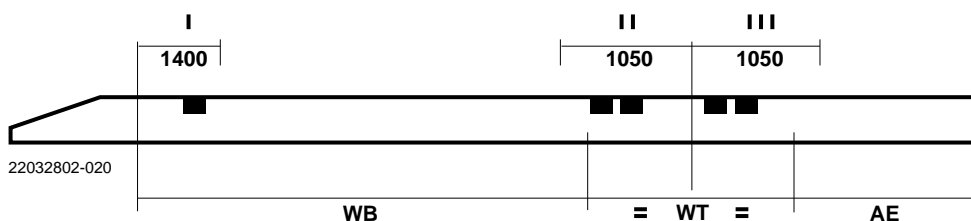

Wheelbase [m]	Rear axle suspension	I	II	III
All	air	1	2	2

3

3.15 FAT CF AND XF

FAT CF75-85 and XF, BAM 1.

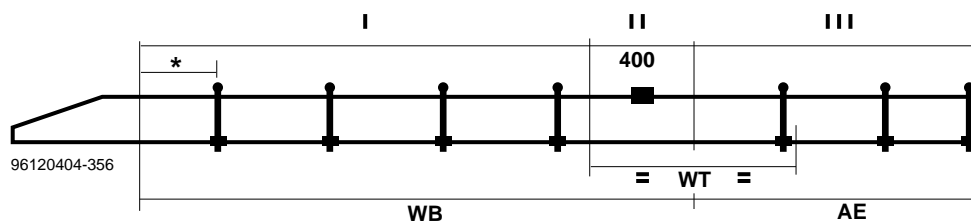

* See 3.3: "First attachment point".

Wheelbase [m]	Rear axle suspension	I	II	III
≤ 4.05	Leaf + air	4	1	3
≤ 4.55	Leaf + air	4	1	3
≤ 5.00	Leaf + air	5	1	3
≤ 5.55	Leaf + air	6	1	3

BODYBUILDERS' GUIDELINES

General information on superstructures

FAT CF75-85 and XF, BAM 2.

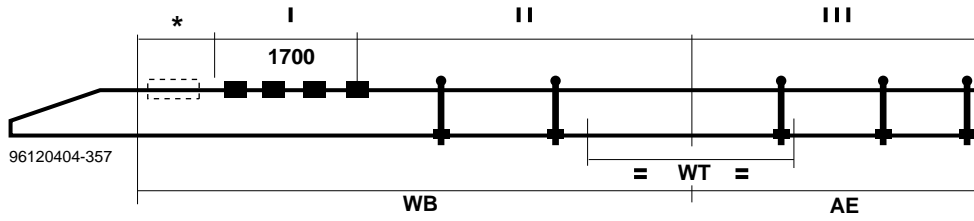

* See 3.3: "First attachment point".

3

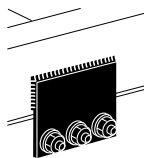
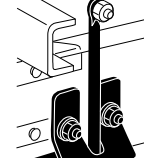
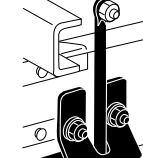
Wheelbase [m]	Rear axle suspension	I	II	III
				
≤ 4.05	Leaf + air	5	1	3
≤ 4.55	Leaf + air	5	1	3
≤ 5.00	Leaf + air	5	2	3
≤ 5.55	Leaf + air	5	2	3

FAT CF75-85 and XF, BAM 3a.

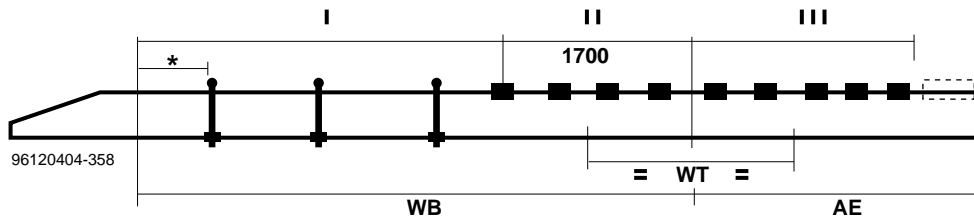

* See 3.3: "First attachment point".

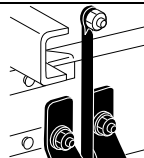
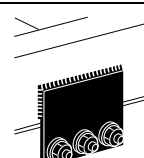
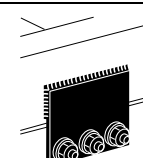
Wheelbase [m]	Rear axle suspension	I	II	III
				
≤ 4.05	Leaf + air	3	5	4
≤ 4.55	Leaf + air	3	5	4
≤ 5.00	Leaf + air	4	5	4
≤ 5.55	Leaf + air	5	5	4

BODYBUILDERS' GUIDELINES

General information on superstructures

FAT CF75-85 and XF, BAM 4.

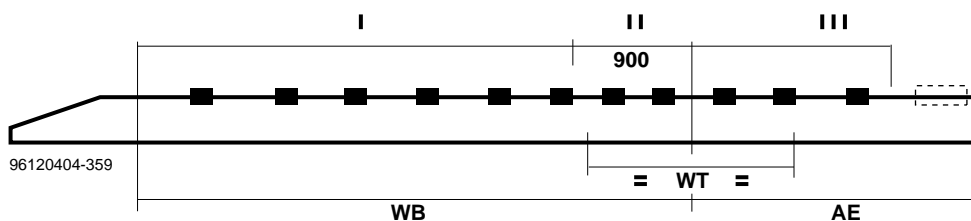

Wheelbase [m]	Rear axle suspension	I	II	III
≤ 4.05	Leaf + air	8	3	4
≤ 4.55	Leaf + air	8	3	4
≤ 5.00	Leaf + air	9	3	4
≤ 5.55	Leaf + air	9	3	4

3

FAT CF75-85 and XF, BAM 5.

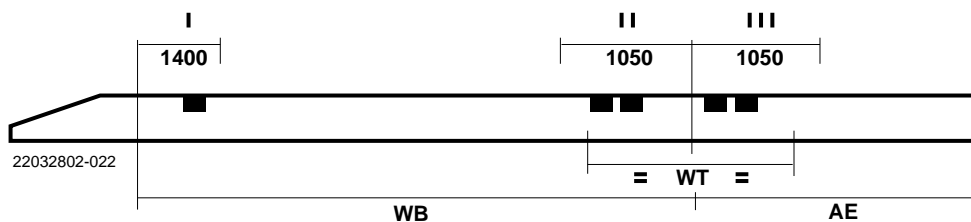

Wheelbase [m]	Rear axle suspension	I	II	III
All	Leaf + air	1	2	2

BODYBUILDERS' GUIDELINES

General information on superstructures

3.16 FAC/FAX CF

FAC/FAX CF85, BAM 2.

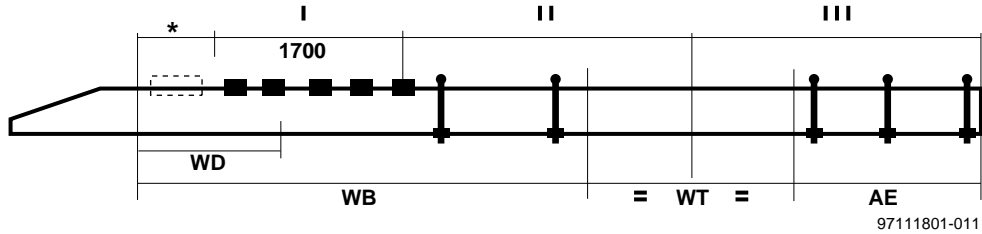

* See 3.3: "First attachment point".

Wheelbase [m]	Rear axle suspension	I	II	III
≤ 5.00	Parabolic + air	5	2	2
≤ 5.70	Parabolic + air	5	3	3
≤ 6.40	Parabolic + air	5	3	4

FAC/FAX CF85, BAM 3a.

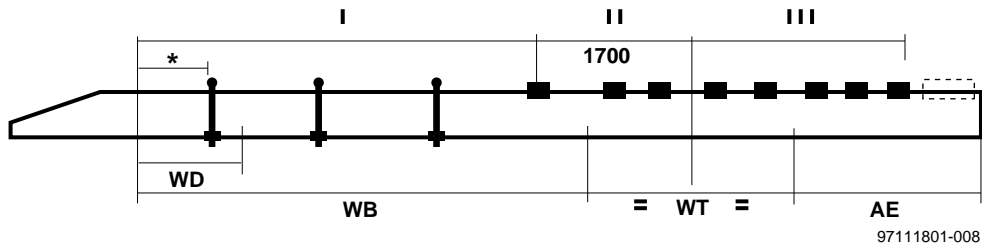

* See 3.3: "First attachment point".

Wheelbase [m]	Rear axle suspension	I	II	III
≤ 5.00	Parabolic + air	3	5	4/5
≤ 5.70	Parabolic + air	4	6	4/5
≤ 6.40	Parabolic + air	5	7	5

BODYBUILDERS' GUIDELINES

General information on superstructures

FAC/FAX CF85, BAM 4.

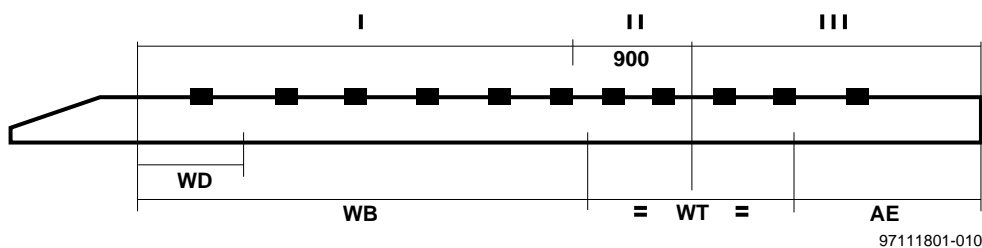

Wheelbase [m]	Rear axle suspension	I	II	III
≤ 5.00	Parabolic + air	7	3	4/5
≤ 5.70	Parabolic + air	8	3	4/5
≤ 6.40	Parabolic + air	9	3	5

3

FAC/FAX CF 85, BAM 5.

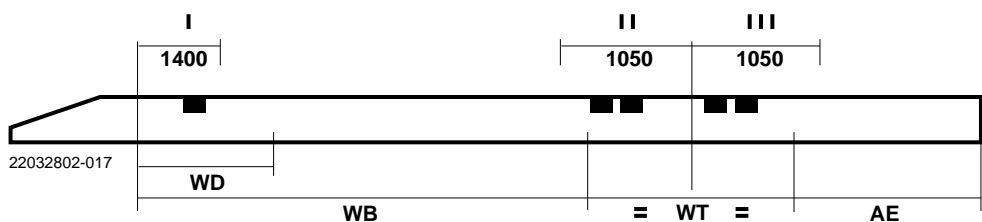

Wheelbase [m]	Rear axle suspension	I	II	III
All	Parabolic + air	2	2	2

BODYBUILDERS' GUIDELINES

General information on superstructures

3.17 FAD CF AND XF

FAD CF75 - 85 and XF, BAM 2.

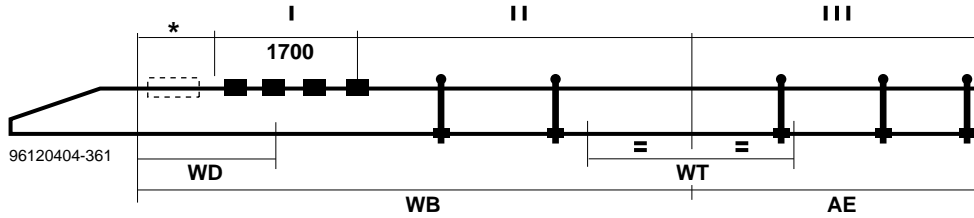

* See 3.3: "First attachment point".

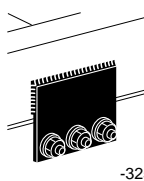
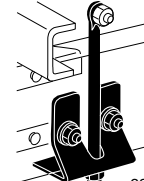
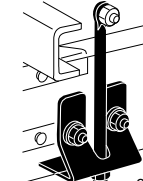
Wheelbase [m]	Rear axle suspension	I	II	III
		 -325	 -324	 -324
≤ 5.05	Leaf + air	5	2	2
≤ 5.70	Leaf + air	5	3	2/3
≤ 7.10	Leaf + air	5	4	4

FAD CF75 - 85 and XF, BAM 3a.

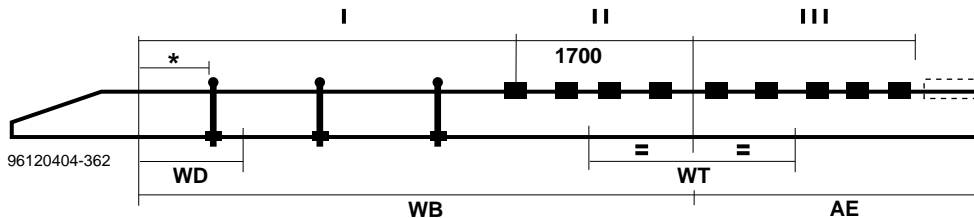

* See 3.3: "First attachment point".

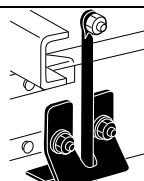
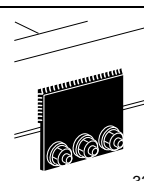
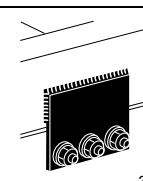
Wheelbase [m]	Rear axle suspension	I	II	III
		 -324	 -325	 -325
≤ 5.05	Leaf + air	4	6	4/5
≤ 5.70	Leaf + air	5	6	4/5
≤ 7.10	Leaf + air	5	7	5

BODYBUILDERS' GUIDELINES

General information on superstructures

FAD CF75 - 85 and XF, BAM 4.

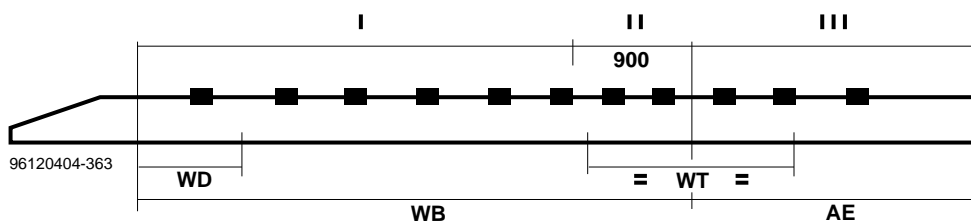

Wheelbase [m]	Rear axle suspension	I	II	III
≤ 5.05	Leaf + air	8	2	4
≤ 5.70	Leaf + air	9	2	4
≤ 7.10	Leaf + air	9	2	4

3

FAD CF75 - 85 and XF, BAM 5.

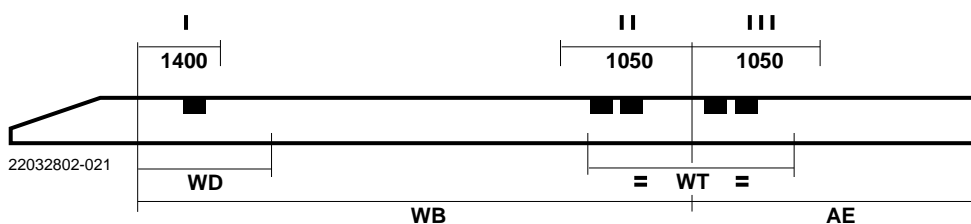

Wheelbase [m]	Rear axle suspension	I	II	III
All	Leaf + air	2	2	2

BODYBUILDERS' GUIDELINES

General information on superstructures

3.18 FAK CF AND XF

FAK CF85 and XF, BAM 2.

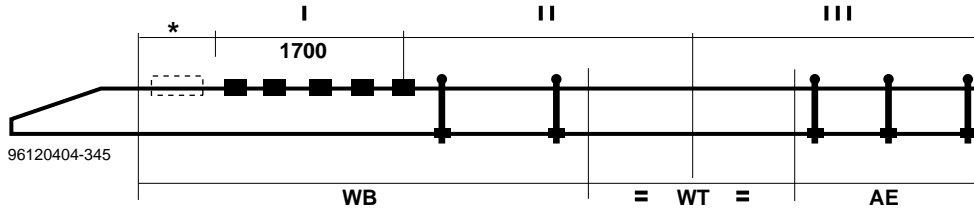

* See 3.3: "First attachment point".

Wheelbase [m]	Rear axle suspension	I	II	III
≤ 4.70	Air	5	2	2
≤ 5.30	Air	5	3	2

FAK CF85 and XF, BAM 3a.

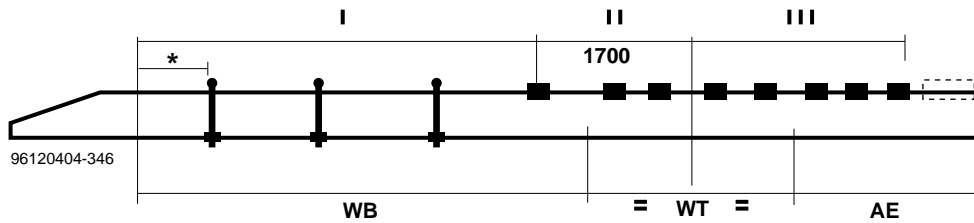

* See 3.3: "First attachment point".

Wheelbase [m]	Rear axle suspension	I	II	III
≤ 4.70	Air	4	6	4/5
≤ 5.30	Air	5	6	4/5

BODYBUILDERS' GUIDELINES

General information on superstructures

FAK CF85 and XF, BAM 4.

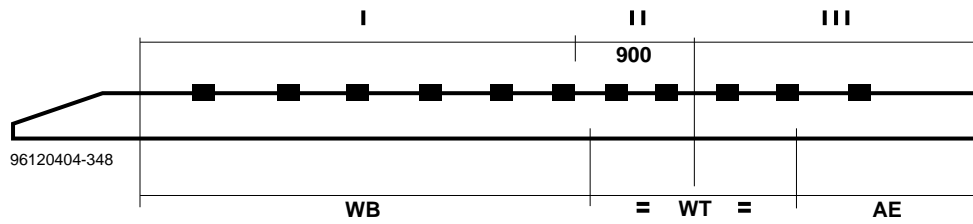

Wheelbase [m]	Rear axle suspension	I	II	III
≤ 4.70	Air	9	3	4
≤ 5.30	Air	10	3	4

3

FAK CF85 and XF, BAM 5.

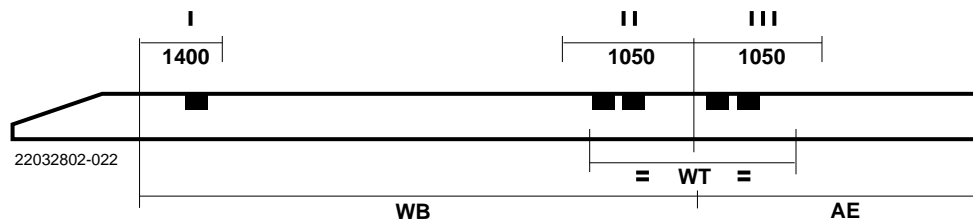

Wheelbase [m]	Rear axle suspension	I	II	III
All	Air	2	2	2

BODYBUILDERS' GUIDELINES

General information on superstructures

3

SUPERSTRUCTURES

	Page	Date
4.1 Fixed body	103	201019
4.2 Body with tail lift	105	201019
4.3 Vehicle loading cranes	108	201019
4.4 Tipper bodies	114	201019
4.5 Tankers	119	201019
4.6 Concrete mixers and concrete pumps	125	201019
4.7 Public utility vehicles	126	201019
4.8 Front mounted equipment	129	201019
4.9 Fifth wheel	130	201019

BODYBUILDERS' GUIDELINES

Superstructures

4

4. SUPERSTRUCTURES

4.1 FIXED BODY

For all the superstructures described in this section, also see section 3: "General information on superstructures".

Body attachment method **BAM 1** is generally sufficient for the mounting of a **fixed body or demountable body with sub-frame**.

The tie rods must be attached to the chassis side members, if possible near or against the cross members. At least one attachment plate must always be fitted between the front and rear spring brackets of the rear axle(s).

A sub-frame is not necessary but can be fitted, in order to obtain the required wheel clearance. Also see the sections 2.10: "Chassis and cabine related dimensions" and 2.14: "Wheel clearance".

Minimum requirement is the fitting on the chassis of a strip or angle brace, to which the cross members of the body can be welded. For the mounting of box bodies **without a sub-frame** DAF recommends the fitting of a number of extra cross members in the floor of the body above or as close as possible to the vehicle axles. As a result of chassis flexing, additional pulling and pushing forces are exerted on the floor of the body. However, the bodybuilder remains at all times responsible for the soundness of a construction and the strength of the self-supporting bodywork.

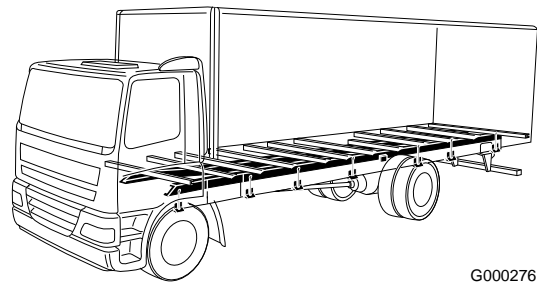

Fixed body with sub-frame, BAM 1

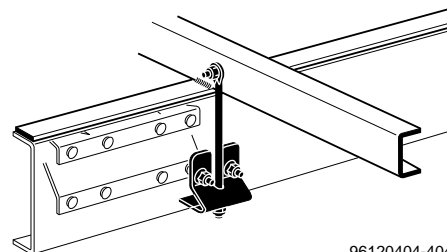

Tie rod mounting, body without sub-frame (with mounting strip)

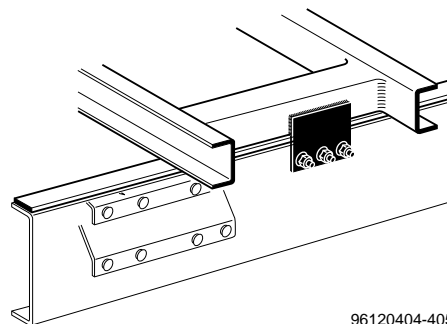

Attachment plate, body without sub-frame (with mounting strip)

(High-)volume body

For (high-)volume applications DAF has various 'Low-Deck' rigid truck chassis in its range with a low frame (260 mm with continuous inner reinforcement flitches). If required, some of these vehicles - for instance, FA/S/R Low-Deck - can be specified with lower suspension, in combination with speed-dependent height control and tyre compression compensation. These chassis require additional strength and/or stiffness of the superstructure.

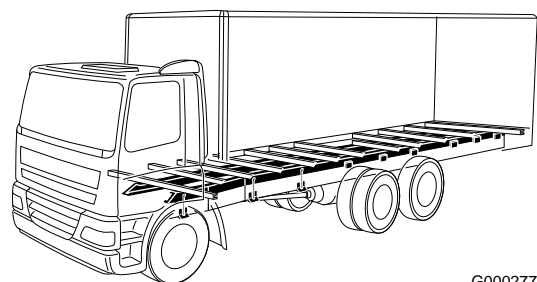

Fixed volume body with a sub-frame, BAM 3a

BODYBUILDERS' GUIDELINES

Superstructures

A (semi-)self-supporting fixed or demountable body, with or without a sub-frame, can be mounted on these chassis. The superstructure should be attached in accordance with body attachment method BAM 1 or BAM 3a. The choice is determined by the moment of inertia of the sub-frame or the floor of the fixed body. The same applies to the minimum required moment of inertia of the floor of demountable bodies. For sub frame dimensions see table.

Attachment according to BAM 1

Min. required body/sub-frame dimensions for chassis with 192 mm and 260 mm high side members with continuous inner reinforcement flitches				
Wheelbase [m]	Chassis rear overhang (AE) [m]	Side member section (A)	Sub frame profile dimensions; st52 [mm]	
			FA (4x2)	FAR/S (6x2)
WB > 5.40 - ≤ 6.00 ⁽²⁾	AE ≤ 0.5 x WB	192x66.5x4.5 + 180x47/62x4	U 180x60x6	not applicable
WB ≤ 5.00	AE ≤ 0.6 x WB	260x75x6 + 245x65x5	-	U 200x70x7
WB ≤ 5.40 ⁽¹⁾	AE ≤ 0.5 x WB	260x75x6 + 246x60x5	U 100x60x6	not applicable
WB ≤ 5.90	AE ≤ 0.6 x WB	260x75x7 + 245x65x5	U 80x50x6	U 220x80x8
WB ≤ 7.30 ⁽¹⁾	AE ≤ 0.5 x WB	260x75x6 + 246x60x5	U 180x60x6	not applicable

(1) FA LF45/55 and CF65 chassis. 260 mm high chassis longitudinal with continuous inner reinforcement profile up to first spring hanger bracket of the rear axle.

(2) FA LF45

Attachment according to BAM 3a

Min. required body/sub-frame dimensions for chassis with 192 mm and 260 mm high side members with continuous inner reinforcement flitches				
Wheelbase [m]	Chassis rear overhang (AE) [m]	Side member section (A)	Sub frame profile dimensions; st52 [mm]	
			FA (4x2)	FAR/S (6x2)
WB > 5.40 - ≤ 6.00 ⁽²⁾	AE ≤ 0.6 x WB	192x66.5x4.5 + 180x47/62x4	U 80x50x6	not applicable
WB ≤ 5.00	AE ≤ 0.6 x WB	260x75x7 + 245x65x5	-	U 100x65x6
WB ≤ 5.40 ⁽¹⁾	AE ≤ 0.6 x WB	260x75x6 + 246x60x5	U 80x50x6	not applicable
WB ≤ 5.90	AE ≤ 0.6 x WB	260x75x7 + 245x65x5	U 80x50x6	U 120x60x6
WB ≤ 7.30 ⁽¹⁾	AE ≤ 0.6 x WB	260x75x6 + 246x60x5	U 140x60x6	not applicable

(1) FA LF45/55 and CF65 chassis. 260 mm high chassis longitudinal with continuous inner reinforcement profile up to first spring hanger bracket of the rear axle.

(2) FA LF45

Wheel clearance at the rear

On versions with speed-dependent height control and tyre compression compensation, the minimum clearance required above the tyres of the driven axle has been reduced to 10 mm with the springs bottoming (metal to metal). Also see section 2.14: "Wheel clearance".

Body with twist-locks

When mounting (demountable) bodies **without sub-frame**, with twist-locks, directly to the vehicle chassis, fit the twist-locks to the side of the chassis frame, using at least 6 M16 flange bolts for each of them.

For (self-supporting) demountable bodies which bear evenly on the chassis over its entire length, there are no specific requirements with respect to the position of the twist-locks, and the dimensions given below may be departed from.

The twist-lock bracket should be fitted near a chassis cross member. If this is impossible, you are referred to section 2.6: "Attachment of components to the chassis".

However, if a demountable body is supported at only a few points, the twist-lock positions given below must be adhered to. If the support points are in other positions, e.g. as in the case of ISO containers, DAF should be contacted.

Position of the twist locks:

- A: 1000 (LF)
- 1400 (CF - XF)

For the mounting of (demountable) bodies **with sub-frame** in which the twist-locks are included, **BAM 1** is specified in most cases (without tail lift).

Make sure that demountable bodies rest on the sub-frame or the chassis members, but in no case directly on the twist-locks!

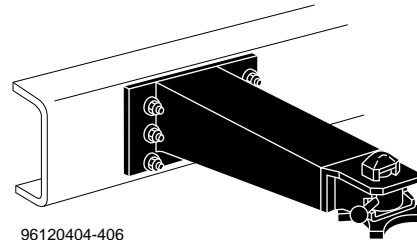

96120404-406

Attachment of twist locks

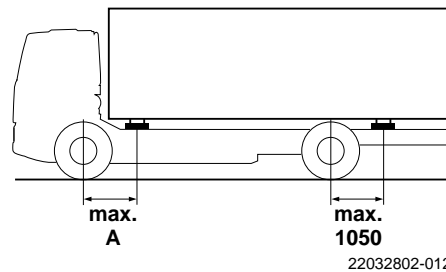

22032802-012

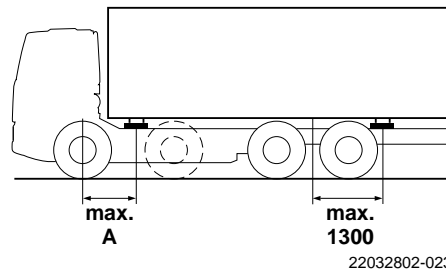

22032802-023

Position of the twist locks

4.2 BODY WITH TAIL LIFT

Body with tail lift

The next table gives the minimum dimensions to be adhered to for sub-frames of bodies with tail lifts **with capacities up to 2000 kg** depending on the type of vehicle, the wheelbase, the chassis dimensions and the rear overhang length. **For tail lifts with a higher capacity than specified in the table, DAF should be contacted.** Tail lifts with a capacity higher than 2500 kg always require the fitting of vehicle support legs to be used during loading and unloading.

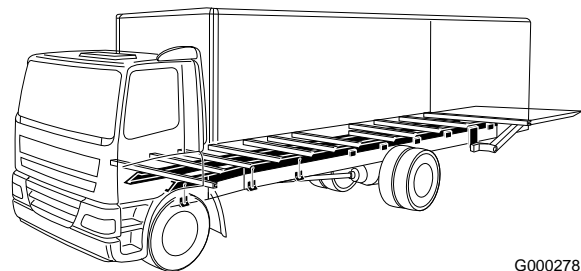

G000278

BODYBUILDERS' GUIDELINES

Superstructures

For the mounting of the sub-frame for a superstructure with tail lift, BAM 3b (CF75-85) or BAM3 (LF / CF65) is specified in most cases.

If according to DAF a sub-frame is not required for structural strength or because of deflection (see note ⁵⁾), a sub-frame in accordance with BAM 1 may still be fitted, for example because of the desired wheel clearance.

Take note of the effect of the tail lift on the vehicle weight distribution in fully laden and partly laden conditions. If necessary, refer to the **TOPEC** calculations for axle load distribution of the partly laden vehicle.

4

Attachment of the tail lift

With this type of superstructure, the tail lift attachment can also be used to attach the sub-frame to the chassis. In that case, the tail lift is bolted to the chassis frame and bolted or welded to the sub-frame.

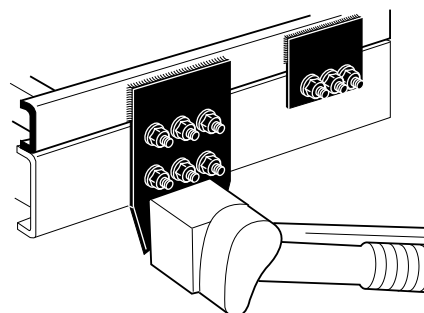

96120404-409

Attachment of the tail lift in accordance with BAM 3b

Superstructure with post type tail lift

A post type tail lift must always be fitted to the body. Consult the supplier of the post type tail lift for the correct mounting instructions.

Sub-frame dimensions

The following table gives an overview of the minimum dimensions required for sub-frames.

Minimum sub-frame dimensions for tail lifts with capacities up to 2000 kg ⁽¹⁾					
Vehicle type	WB [m]	Chassis sections in rear overhang	Maximum AE ⁽⁵⁾	Sub-frame ⁽²⁾ sections	
FA LF45 ⁽³⁾	≤ 4,30	192x66.5 x4.5	0.50xWB	U 120x60x6	
	≤ 5,40			U 140x60x6	
FA LF45 ⁽⁴⁾ 12 tonnes GVM	≤ 4,30	192x66.5x4.5+180x62x4		U 120x60x6	
	≤ 5,40			U 140x60x6	
FA LF55 FA CF65	≤ 4,20	260x75x6		U 80x60x6	
	≤ 5,35			U 120x60x6	
	≤ 6,30			U 160x60x6	
	≤ 7,30			U 180x60x6	
FAN LF55	≤ 4,20	260x75x6		0.55xWB	U 180x60x6
	≤ 5,35			U 200x60x6	
FA CF75-85 FA XF	≤ 4,90	260x75x7	0.50xWB	U 160x60x6	
		310x75x7		U 80x60x6	
	≤ 5,70	260x75x7		U 160x60x6	
		310x75x7		U 100x65x6	
		260x75x7 + 245x65x5		U 100x65x6	
≤ 6,90	310x75x7	U 120x60x6			
FAG CF75-85	≤ 5,35	310x75x7 + 295x65x5	0.40xWB	U 80x60x6	
	≤ 6,60	310x75x7 + 295x65x5		U 140x60x6	
FAS/R CF75 FAS/R CF85 FAS/R XF FAN CF75-85 FAN XF	≤ 3,80	260x75x7 + 245x65x5	0.55xWB	U 100x60x6	
		310x75x7		U 160x60x6	
	≤ 5,50	310x75x7		U 200x60x6	
	≤ 4,20	310x75x7 + 295x65x5		U 100x65x6	
	≤ 4,80	260x75x7 + 245x65x5		U 180x60x6	
	≤ 5,30	310x75x7 + 295x65x5		U 160x60x6	
	≤ 5,90	260x75x7 + 245x65x5		U 200x60x6	
≤ 6,10	310x75x7 + 295x65x5	U 200x60x6			

(1) Consult DAF for tail lifts with a higher capacity, and for other combinations not mentioned in this overview.

(2) The determination of the sub-frame dimensions is based on the use of Steel 37 (Fe 360 B according to EN10025).

(3) Tail lift capacity ≤ 1000 kg.

(4) Tail lift capacity ≤ 1500 kg.

(5) Body length and AE to be determined on the basis of axle load calculation; consult TOPEC.

BODYBUILDERS' GUIDELINES

Superstructures



WARNING! Vehicle stability during operation of any superstructure system is the responsibility of the bodybuilder and the user. The user should at all times make sure that vehicle stability is guaranteed. It is therefore important that clear instructions for use of the superstructure should be provided by the bodybuilder on or supplied with the vehicle.

For more information see:
1.3: "Verificaton of superstructure"

4

4.3 VEHICLE LOADING CRANES

The attachment method for a vehicle loading crane depends upon the position of the crane:

- crane immediately behind cab: **BAM 2**, or
- crane at rear end of chassis: **BAM 3a**. or **BAM 3** (LF and CF65 series)
- crane in combination with more than 2 crane supports: **BAM 4**.

Consult DAF for any position other than the two above-mentioned crane positions, for instance for cranes mounted amidships.

Vehicle series	Side member dimensions [mm]	Flitch dimensions [mm]	Max. crane capacity		Number of crane supports
			Crane behind cab. ⁽¹⁾ [kNm]	Crane at rear overhang ⁽¹⁾ [kNm]	
FA LF45	192x66x4,5	(180x62x4,0) (2)	100	75	2
FA CF65 FA / FAN LF55	260x75x6,0	(245x60x5,0) (2)	150	100	
FA CF75-85 FA XF	260x75x7,0 310x75x7,0	- (295x65x5,0) (2)	200	150	
FAS/R FAG FAN CF75-85 XF	260x75x7,0 310x75x7,0 310x75x7,0 310x75x8,5	245x65x5,0 - 295x65x5,0 292x65x8,5	250 300	170 200	2 / 4
FAC FAD FAK FAX CF85 XF	310x75x6,0 310x75x7,0 310x75x8,5	295x65x5,0 295x65x5,0 292x65x8,5	400	250	

(1) Position of the crane; crane behind the cab, see Graph A, and crane at the rear overhang, see Graph B.

(2) Dependent of vehicle layout, see chassis drawing.

Attachment of the crane base

The number of attachment bolts under the crane base depends on the attachment method and the maximum capacity of the crane. It should always be determined by and under the responsibility of the supplier of the crane. In any case, the part of the sub-frame on which the vehicle loading crane is to be mounted, must be attached to the chassis frame of the vehicle with large attachment plates and flange bolts.

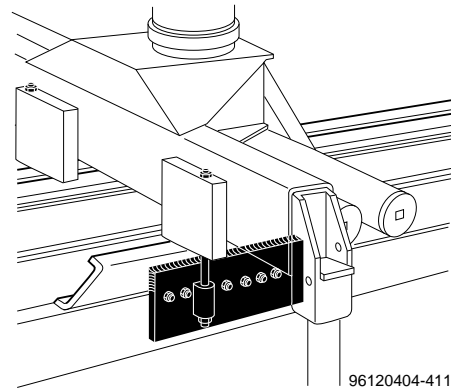

96120404-411
Attachment of the crane base

Sub-frame dimensions

Always use a sub-frame when mounting a crane superstructure on a chassis frame. For the dimensions of the required sub-frame, refer to one of the two graphs shown below. The following information will help you to choose the applicable graph:

The 2 graphs (A and B) can be used to determine the sub-frame dimensions as follows. Graph A: from a crane capacity of, for instance, 140 kNm, draw an imaginary horizontal line to the right until it crosses the vertical line of the side member, for instance 260x75x6 (LF55). The reading for the sub-frame dimensions is box section 160x80x8. The dimensions of the chassis members (possibly with flitches) in the indicated critical zones (*) of the chassis can now be read from the bodybuilders' drawings.

These drawings are available from DAF and they can be found as digital files on the TOPEC CD-ROM and the internet (www.daf.com).

Graph A: Crane immediately behind cab
Sub-frame material Fe 510 D, according to EN 10025 (St 52-3 according to DIN 17100).

Graph B: Crane at rear end of chassis
Sub-frame material Fe 510 D, according to EN 10025 (St 52-3 according to DIN 17100).

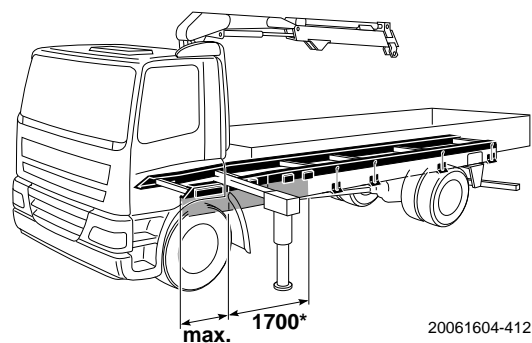

20061604-412

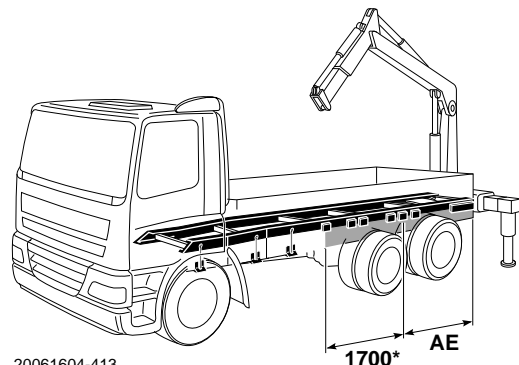

20061604-413

Critical zones for mounting of cranes

Torsional stability

If a vehicle loading crane is fitted at the rear end of the chassis, a torsional stiffener must be provided in the rear overhang. The torsional stiffening may be provided by the superstructure itself or by a sub-frame stiffener; also see 'Torsional stability of the sub-frame' in section 3.1: "Superstructure with sub-frame". The stability is determined by the vehicle, the load, the

BODYBUILDERS' GUIDELINES

Superstructures

position of the support legs and the structure of the surface under the support legs. **Vehicles with front leaf / rear air-suspension or full air-suspension.** During crane operation; deflating the suspension of the vehicle and then lifting the chassis using the crane support legs can lead to damage to the air bellows. Therefore the ECAS air-suspension should be equipped with the function to deflate the air-suspension to low residual pressure to protect the air-bellows. For installation of this function, please contact DAF Sales Engineering.

Vehicle stability during operation of any superstructure system is the responsibility of the bodybuilder and the user. The user should at all times make sure that vehicle stability is guaranteed. It is therefore important that clear instructions for use of the superstructure should be provided on or supplied with the vehicle.

Graph A

Minimum sub-frame dimensions for:

- **crane immediately behind the cab,**
- **sub-frame material Fe 510 D.**

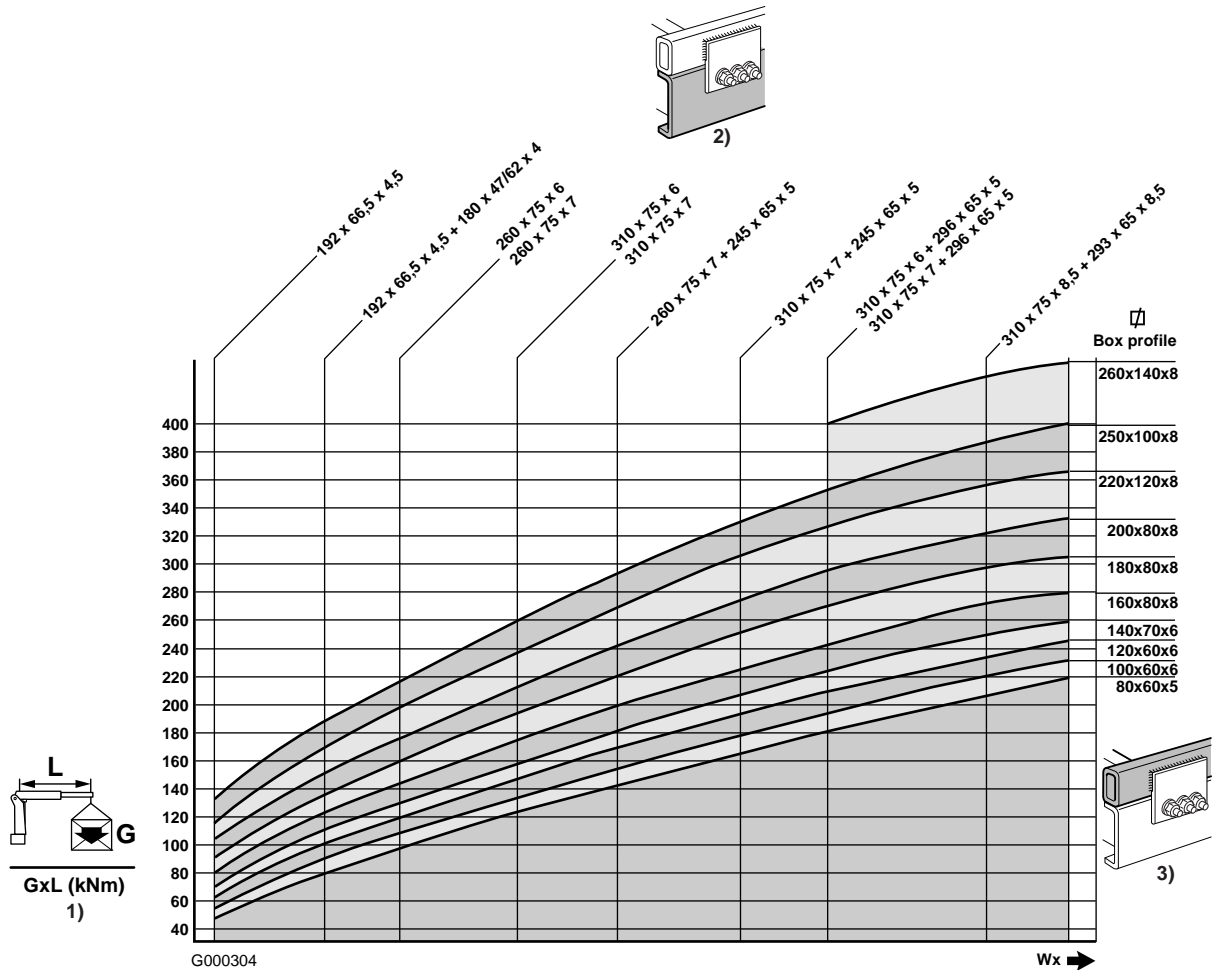
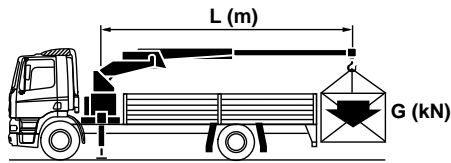

1. Vehicle loading cranes, see section 4.3.
2. Chassis dimensions, see section 2.10: "Chassis and cabine related dimensions".
3. Superstructure with sub-frame, see section 3.1: "Superstructure with sub-frame".

Graph B

Minimum sub-frame dimensions for:

- crane at rear end of chassis,
- sub-frame material Fe 510 D.

BODYBUILDERS' GUIDELINES

Superstructures

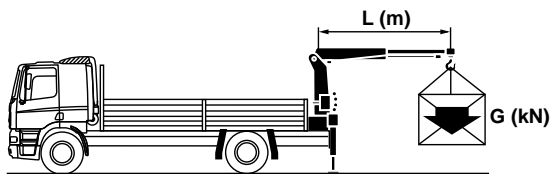

4

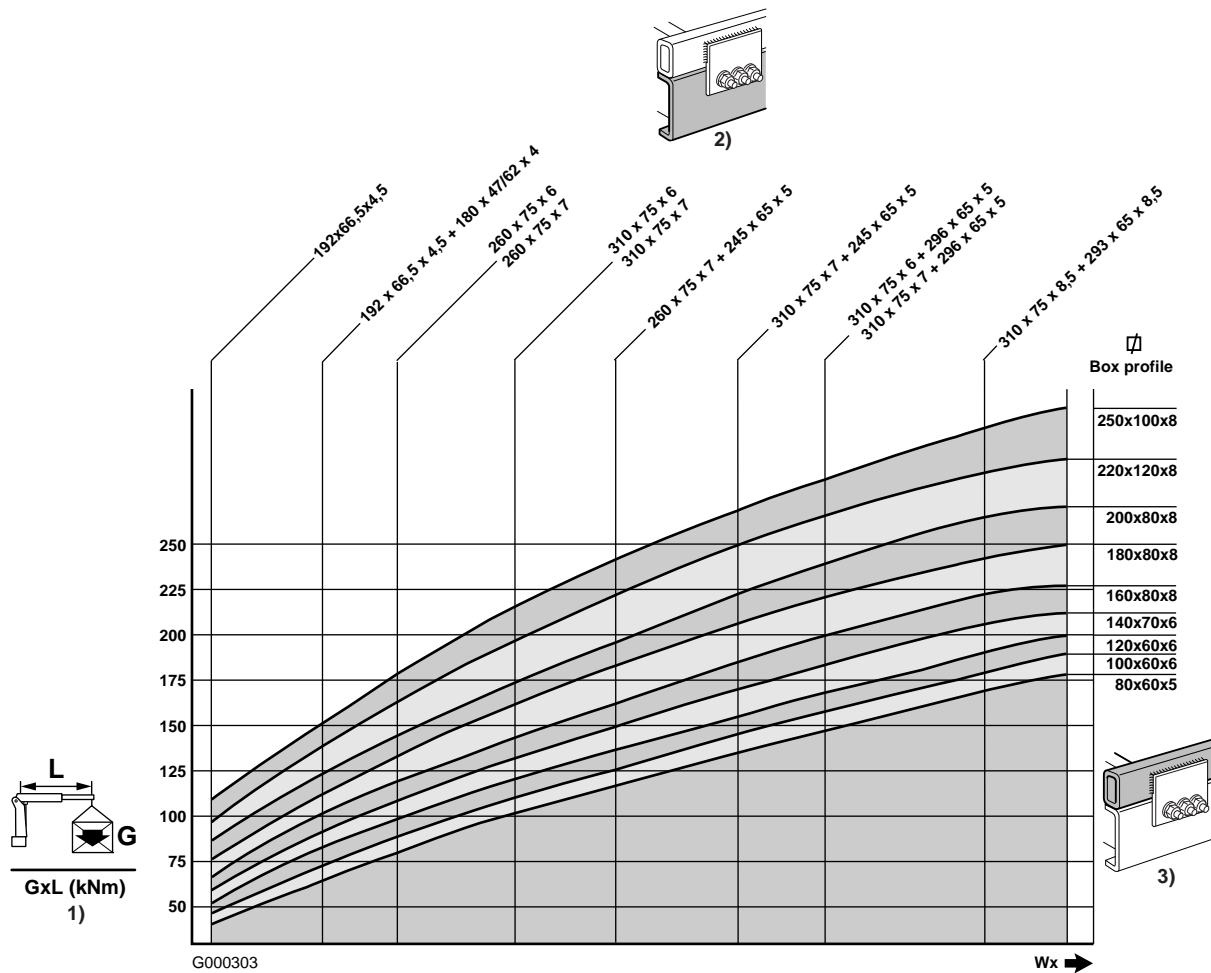

1. Vehicle loading cranes, see section 4.3.
2. Chassis dimensions, see section 2.10: "Chassis and cabine related dimensions".
3. Superstructure with sub-frame, see section 3.1: "Superstructure with sub-frame".

Recovery vehicles and hydraulic platforms

The superstructure should always be attached to the chassis with a sub-frame or a self-supporting ("pontoon-type") sub-frame construction. If the latter type is used, it is generally not possible to provide a rigid attachment because of the unequal distribution of strength and stiffness between the chassis and sub-frame and consequently the location of the neutral line of the assembly. If the vehicle chassis frame has to contribute to the strength of the superstructure, DAF should be contacted.

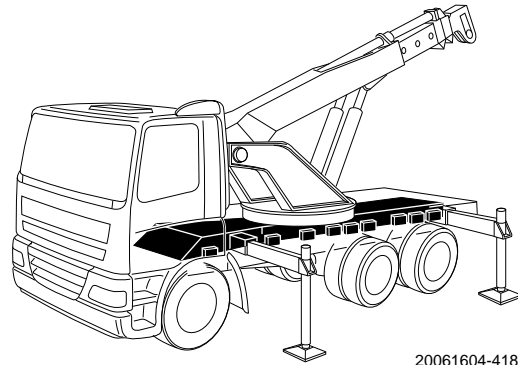

Recovery vehicle, BAM 4

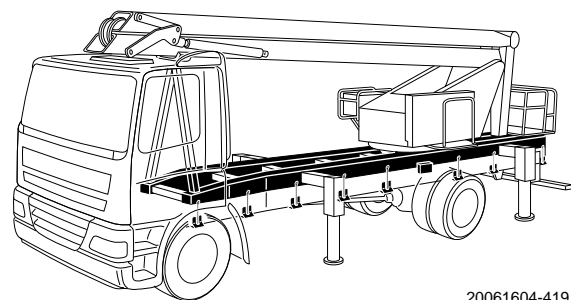

Hydraulic platform with 'pontoon-type' sub-frame, BAM 1

Vehicles with front leaf / rear air-suspension or full air-suspension

During crane operation; deflating the suspension of the vehicle and then lifting the chassis using the crane support legs can lead to damage to the air bellows. Therefore the ECAS air-suspension should be equipped with the function to deflate the air-suspension to low residual pressure to protect the air-bellows. For installation of this function, please contact DAF Sales Engineering.



WARNING! Vehicle stability during operation of any superstructure system is the responsibility of the bodybuilder and the user. The user should at all times make sure that vehicle stability is guaranteed. It is therefore important that clear instructions for use of the superstructure should be provided by the bodybuilder on or supplied with the vehicle.

***For more information see:
1.3: "Verificaton of superstructure"***

BODYBUILDERS' GUIDELINES

Superstructures

4.4 TIPPER BODIES

Attachment methods for tipper bodies		
Tipper with front-end ram	Version 1	BAM 3a
Tipper with central ram	Version 2	BAM 3a
Three-way tipper	Version 3	BAM 4 or BAM3a
Tipping demountable body	Version 4	BAM 4

For the mounting of tipper bodies, the following general guidelines always apply:

- Tipper bodies should preferably be fitted to chassis with 310 mm high side members. Depending on the application, tipper bodies may, however, be fitted to chassis with 192 or 260 mm high side members; however, in such cases the sub-frame will have to be of a heavier design than when a chassis with 310 mm high side members is used.
- **Vehicles with front leaf / rear air-suspension or full air-suspension.** During tipping or body swop for demountables, the air suspension should be lowered to bump-stop. This option can be activated automatically or manual, please contact DAF Sales Engineering.
- It is not permitted to mount tipper bodies on the FAN LF55, FAR chassis (6x2 vehicles with single wheels on the trailing axle) and the FAX chassis (8x2 vehicles with single wheels on the trailing axle), because this type of vehicles was not developed for this application. If, for a certain application, a tipper body **must** be used on such chassis, consultation with DAF is required, on the one hand for verification and on the other to be certain that the conditions set can be met.

In the table you will find the sub-frame data for various tipper versions and also the maximum distance (B) from pivot point to rear axle.

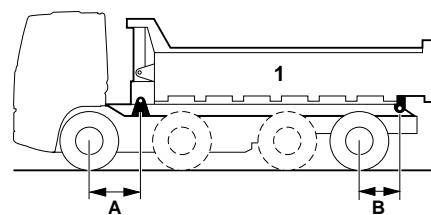

G000300

Tipper with front-end ram

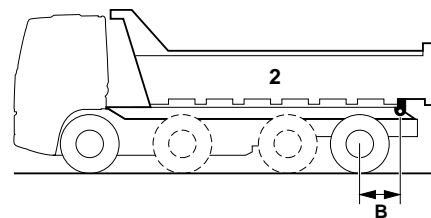

G000299

Tipper with central ram

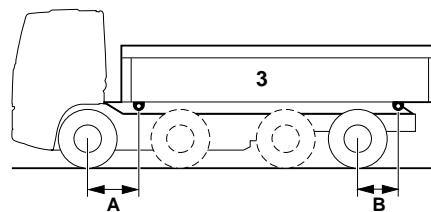

G000298

Three-way tipper

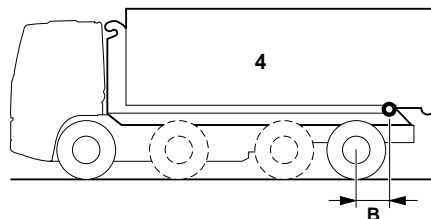

G000297

Tipping demountable body

Sub-frame dimensions

Data for tipper bodies and sub-frames							
Vehicle type	GVM max. [tonne]	WB [m]	Chassis section near rear axle [mm]	Tipper type	A Max. [mm]	B Max. [mm]	$W_{x,min}^{(1)}$ [cm ³]
FA LF45	7.5-12	≤ 3.65	192x66,5x4.5	1,-,-,-	1000	1050	⁽²⁾
				-,2,3,4	1000	1050	41.0
FA LF55	13-18	≤ 4.30	260x75x6	1,-,-,-	1000	1200	⁽²⁾
				-,2,3,4	1000	1200	41.0
FA CF65	19	≤ 4.45	260x75x6	1,-,-,-	1200	1050	61.0
				-,2-3-4	1200	1050	86.0
FA CF65 FA CF75-85 FA XF	20.5	≤ 4.90	310x75x7	1,2,3,4	1200	1050	26.5
				1,2,-,-	1200	1300	41.0
FA CF65 FA CF75-85 FA XF	20.5	≤ 4.90	260x75x7	1,2,3,4	1200	1050	61.0
				1,2,-,-	1200	1300	86.0
FAG CF75-85	28	≤ 5.90	310x75x7+ 295x65x5	1,2,3,4	1200	1050	85.0
				1,2,-,-	1200	1300	115.0
FAS CF75-85 FAS XF FAN CF75-85	28	≤ 4.20	310x75x7	1,2,3,4	1200	650	116.0
				1,2,-,-	1200	800 ⁽⁴⁾	150.0
FAS CF75-85 FAS XF FAN CF75-85	28	≤ 4.80	310x75x7 + 295x65x5	1,2,3,4	1200	650	26.5
				1,2,-,-	1200	800 ⁽⁴⁾	41.0
FAT CF75-85 FAT XF	28	≤ 5.55	310x75x7 + 295x65x5	1,2,3,4	1200	650	85.0
				1,2,-,-	1200	800 ⁽³⁾	115.0
FAT CF85 FAT XF	33	≤ 5.55	310x75x8.5 + 292x65x8.5	1,2,3,4	1200	650	85.0
				1,2,-,-	1200	800 ⁽³⁾	115.0
FAX CF85	34 ⁽⁶⁾	≤ 5.70	310x75x7 + 295x65x5	1,2,-,-	1200	650	85.0
					1200	800 ⁽³⁾	115.0
FAC CF85	34 ⁽⁶⁾	≤ 5.70	310x75x7 + 295x65x5	1,2,3,4	1200	650	85.0
				1,2,-,-	1200	800 ⁽³⁾	115.0
FAC CF85	37 ⁽⁶⁾	≤ 6.20	310x75x8.5 + 292x65x8.5	1,2,3,4	1200	650	85.0
				1,2,-,-	1200	800 ⁽³⁾	115.0
FAD CF85 FAD XF	34 ⁽⁶⁾	≤ 6.40	310x75x7 + 295x65x5	1,2,3,4	1200	650	85.0
				1,2,-,-	1200	800 ⁽³⁾	115.0
FAD CF85 FAD XF	37 ⁽⁶⁾	≤ 6.40	310x75x8.5 + 292x65x8.5	1,2,3,4	1200	650	85.0
				1,2,-,-	1200	800 ⁽³⁾	115.0
FAD CF85 FAD XF	44 ⁽⁶⁾	≤ 6.40	310x75x8.5 + 292x65x8.5	1,2,3,4	1200	650	250
				1,2,-,-	1200	800 ⁽³⁾	285
FAK XF	35.5 ⁽⁶⁾	≤ 5.30	310x75x7 + 295x65x5	1,2,3,4	1200	1000 ⁽⁵⁾	160

(1) Minimum required moment of resistance of one sub-frame side member.

(2) A sub-frame is not required for chassis strength or because of deflection, but can be mounted, for instance, to obtain sufficient wheel clearance.

BODYBUILDERS' GUIDELINES

Superstructures

- (3) Rear axles airsuspension B Max. is 1000 mm.
- (4) FAS rear axles airsuspension B Max. is 1000 mm.
- (5) Rear axles airsuspension.
- (6) Independent chassis support in the rear overhang is recommended for increased stability during tipping operation.

Attachment of ram and tipping pivot

Both the front-end ram and the central ram should be attached in the sub-frame. Allowance should be made for the space required for driveline movements. The tipping pivot at the rear of the tipper body should be attached to the sub-frame.

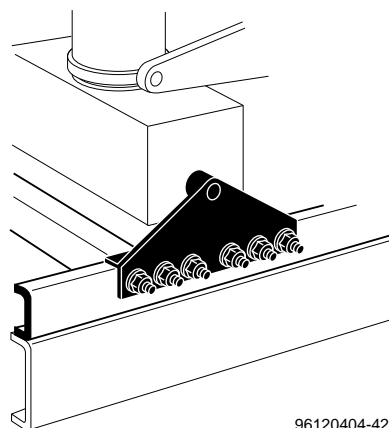

Attachment of the front-end ram

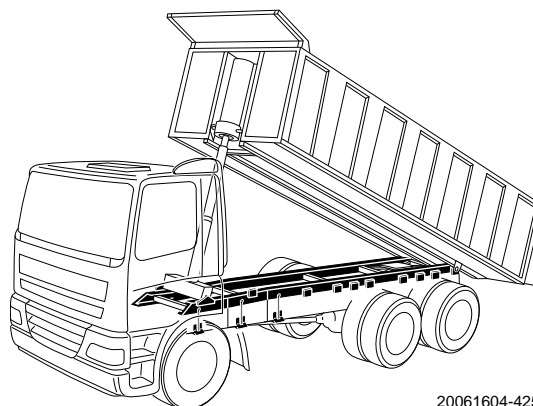

Tipper with front-end ram

Attachment of guide plate

The sub-frame should be provided with guide plates at the front end of the tipper body to prevent lateral movement of the body. To prevent torsion in the sub-frame, it is recommended to fit a cross member in the sub-frame here, too.

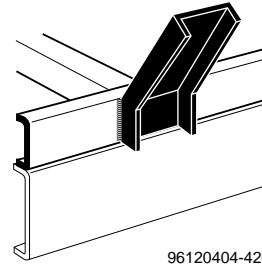

96120404-426
Guide plate



20061604-427
Tipper with central ram

Attachment of ball pivot (three-way tipper)

The tipper body pivot should be attached to the sub-frame. Braces can be bolted into position and, if they are attached to the sub-frame, they will also serve as retainer plates.

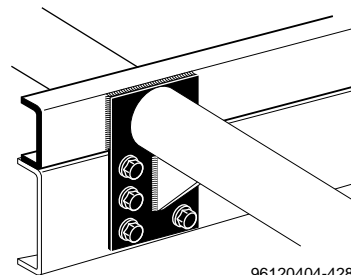

96120404-428
Attachment of ball pivot

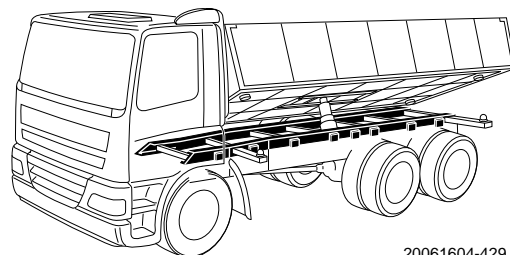

20061604-429
Three-way tipper

BODYBUILDERS' GUIDELINES

Superstructures

Attachment of the demounting system

Irrespective of the type of system, the demounting system should be attached to the sub-frame. If the sub-frame of the demounting system is wider than the vehicle chassis frame, consoles can be used to mount the demounting system. The top of the consoles must be flush with the top of the chassis frame. If DAF consoles are used for this purpose, the locating edge at the top of their rear wall should be removed. The consoles can be welded to the sub-frame and attached to the chassis with flange bolts; also see section 3.2: "BAM's - body attachment methods".

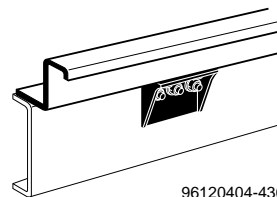

96120404-430

Attachment of sub-frame with console

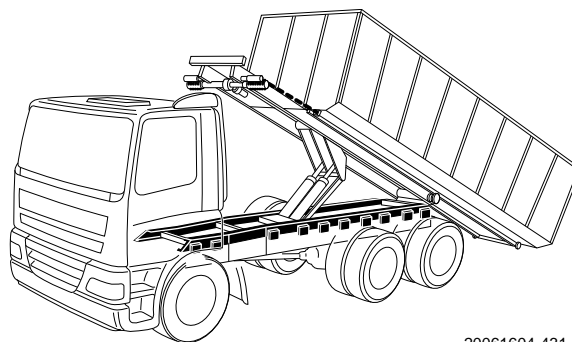

20061604-431

Tipping demountable body

4

Stability by torsional stiffeners

In all cases, torsional stiffeners should be fitted in the sub-frame rear overhang; see: 'Stability by torsional stiffening of the sub-frame' in section 3.1: "Superstructure with sub-frame". Stability during tipping depends on a number of factors and is positively influenced by:

- greater rigidity in the chassis (rear overhang) and body,
- ram(s) positioned as far as possible to the front (front-end ram),
- shortest possible rear overhang and favourable position of tipping pivot,
- Independent chassis support in the rear overhang. This chassis support can be fitted at the rearmost axle, however the axle load must not exceed twice the maximum technical axle load. Alternatively the chassis support can be fitted at the end off the chassis and supporting on ground level.
- tipping stabiliser (scissors construction) between body and chassis,
- skilled operation and firm level surface for the vehicle to stand on.

Vehicle stability during operation of any superstructure system is the responsibility of the bodybuilder and the user. The user should at all times make sure that vehicle stability is guaranteed. It is therefore important that clear instructions for use of the superstructure should be provided by the bodybuilder on or supplied with the vehicle.

For more information see: 1.3: "Verificaton of superstructure"

4.5 TANKERS

General

For torsionally rigid (self-supporting) body constructions, including tanker superstructures, console attachment can be opted for. However, at certain vehicle speeds and under certain conditions, such an attachment may lead to annoying bending vibrations in the frame, which may have a highly adverse effect on the driving comfort. It is therefore important not to exceed the indicated maximum positions of attachment points on the frame.

In chapter 3 is shown how many consoles per vehicle type and chassis segment are required. In the event that less consoles per segment are used, these consoles must be lengthened to have a longer contact surface with the longitudinal. The chassis load by the tanker support must be in relation with the console dimension and attachment.

The console attachment introduces a local vertical point load which results in local stresslevel in the chassis. Therefore the chassis longitudinal must be reinforced with an innerliner, in case there is no innerliner reinforcement a subframe must be mounted.

The centre of gravity of the tanker body must be as low as possible, in order to decrease the risc for vehicle verturning.

On trucks with tanker superstructures which are to transport liquid goods, the need for lengthways and crossways baffles must be considered.

The bodybuilder is free to make a choice from the undermentioned body attachments, depending on which construction (according to his own insights and experience) is most suitable for the superstructure in question. In all cases, the bodybuilder remains responsible for ensuring that the tank construction is sufficiently strong for the selected attachment and/or mounting method of the tanker body.

BODYBUILDERS' GUIDELINES

Superstructures

Tanker body with sub-frame

Body **attachment method BAM 1** should be used for a tanker body with sub-frame. Take care that the load is evenly distributed over the sub-frame, by using sufficient tank brackets. Also see the figure opposite.

- A: 1000 (LF)
1400 (CF - XF)

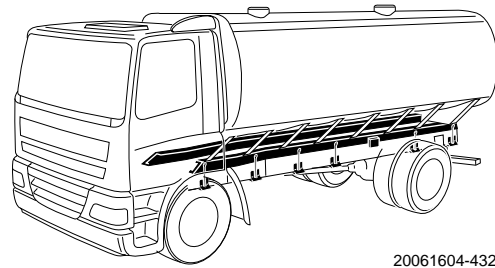

20061604-432

Body with sub-frame

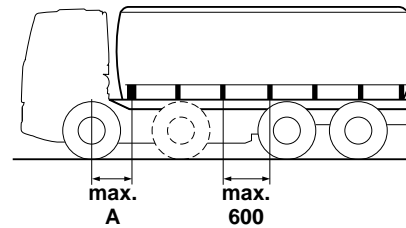

22032802-015

Positions of superstructure attachment points

Tanker body on consoles (with or without onboard weighing system)

The console attachment introduces a local vertical point load which results in local stress in the chassis. Therefore the chassis longitudinal must be reinforced with an innerliner, in case there is no innerliner reinforcement a subframe must be mounted. The console attachment might also introduce lateral torsion to the chassis longitudinal. To eliminate this lateral torsion a cross member must be present. Check section consoles in 3.2: "BAM's - body attachment methods".

Console attachment, fixed

Body attachment method **BAM 5** is used for this. Fixed attachment of the tanker superstructure is particularly suitable for two-axle vehicles. Spacer bushes with a length of at least 30 mm should be used (see section 3.4: "Type of superstructure/BAM matrix").

- A:** 1000 (LF)
1400 (CF - XF)

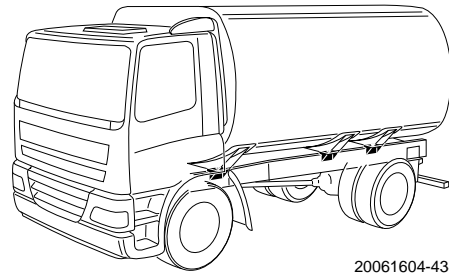

20061604-434

Console attachment

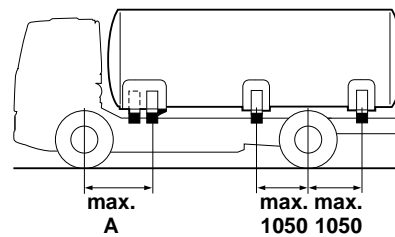

22032802-014

Positions of consoles on two-axle vehicles

Console attachment, semi-flexible

Body attachment method **BAM 5** is used for this. Consoles with pressure springs are used at the front. Spring pre-tension should be 3 kN per spring. In relation with a vertical static console load of 20 kN two pressure springs should be used, the pre-tension of each spring should be 3 kN. The minimum spring rate per spring is 225 N/mm. Fixed superstructure-to-console-attachment is used at the rear. For this, use spacer bushes with a length of at least 30 mm (see section 3.4: "Type of superstructure/BAM matrix").

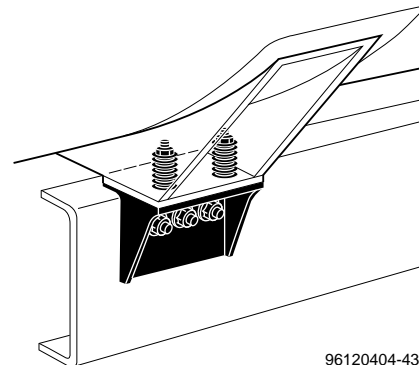

96120404-436

Console with pressure springs

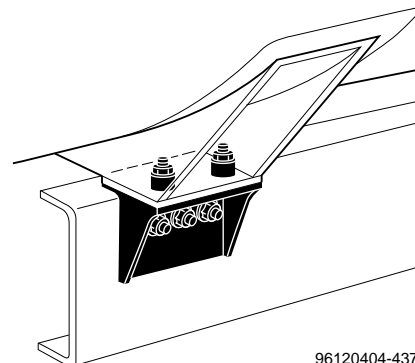

96120404-437

Console with fixed attachment

BODYBUILDERS' GUIDELINES

Superstructures

Console attachment, all-flexible

Body **attachment method BAM 5** is used for this. Consoles with pressure springs are used at both front and rear. At the rear, rubbers are added. These rubbers must always rest directly on the console and may never be placed on, for example, spacers. The rubbers used must not be compressed more than 1 mm under a static load.

The tank brackets on consoles with pressure springs and rubber must have a provision for fixation of the superstructure in the longitudinal and transverse directions.

A: 1000 (LF)
1400 (CF - XF)

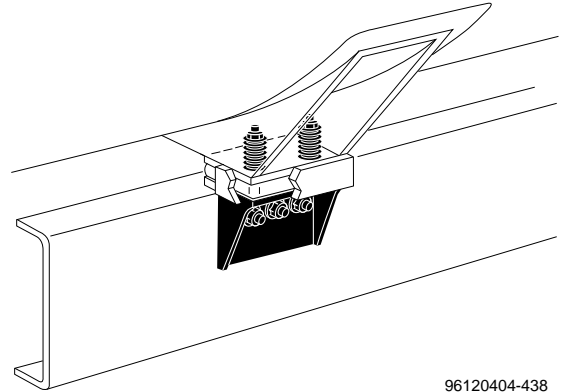

Console with springs and rubber

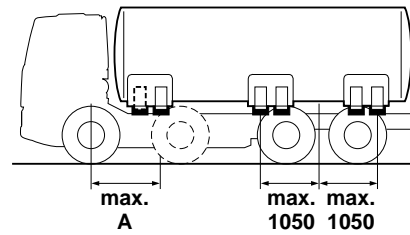

22032802-013

Position of consoles on multi-axle vehicles

Console attachment, three-point (two-axle vehicles)

Body attachment method **BAM 5** is used for this. The front mounting point of the tank is a spring-loaded swinging unit. In relation with a vertical static console load of 20 kN per side as specified spring tension can be seen from the graph. With a given dimension 'a', representing the distance between the console springs, the spring tension should be 'P'.

The consoles placed in front of the rear axle have pressure springs. Those placed behind the rear axle have fixed attachment.

- A:** 1000 (LF)
1400 (CF - XF)

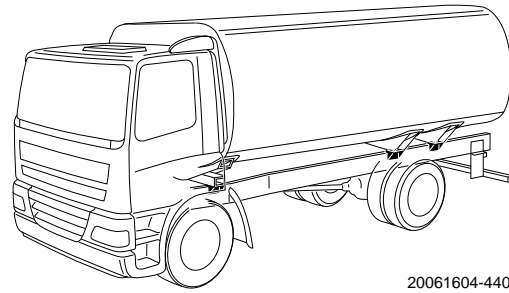

20061604-440

Three-point attachment on two-axle vehicles

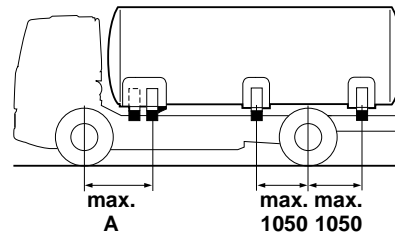

22032802-014

Position of consoles

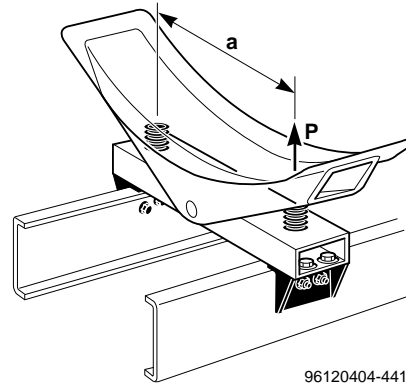

96120404-441

Oscillating unit

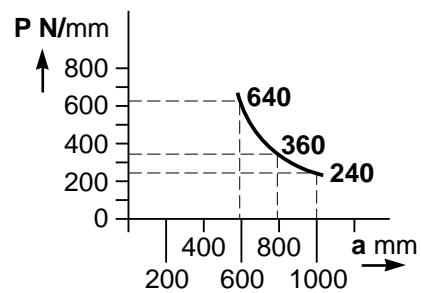

96120404-442

Graph

BODYBUILDERS' GUIDELINES

Superstructures

Console attachment, three-point (multi-axle vehicles)

Body attachment method **BAM 5** is used for this. The front mounting point is a tank bracket attached with rubbers and springs to a cross member resting on consoles.

The spring force of the machine rubbers used should be:

- vertical: $6 + 0.5 \text{ kN/mm}$,
- horizontal: $7 + 0.5 \text{ kN/mm}$.

The consoles placed in front of the rear axle centre have pressure springs. Those placed behind the rear axle have fixed attachment.

A: 1000 (LF)
1400 (CF - XF)



WARNING! Operation of any superstructure system is the responsibility of the bodybuilder and the user. It is therefore important that clear instructions for use of the superstructure should be provided by the bodybuilder on or supplied with the vehicle. For more information see: 1.3: "Verificaton of superstructure"

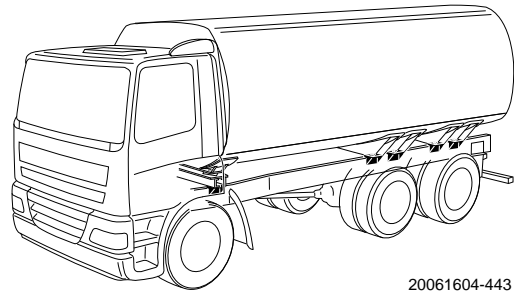

20061604-443

Three-point attachment on multi-axle vehicles

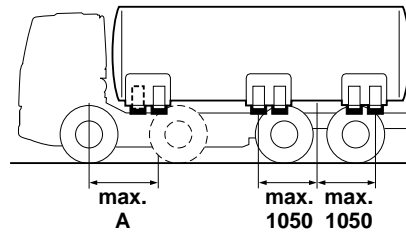

22032802-013

Positions of consoles on multi-axle vehicles

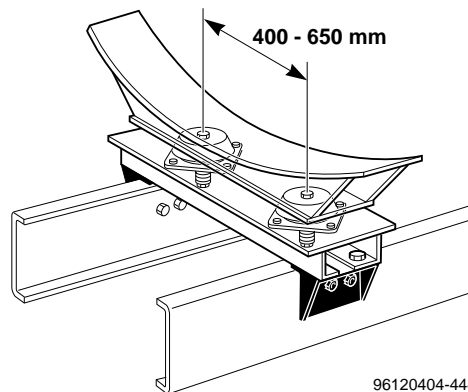

96120404-444

Front mounting

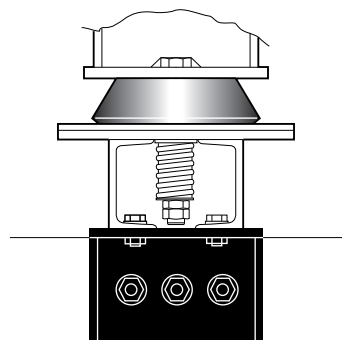

96120404-445

Mounting of machine rubber

4.6 CONCRETE MIXERS AND CONCRETE PUMPS

A sub-frame should always be used for concrete mixers, concrete pumps and combined concrete mixer/pump superstructures. BAM 4 (fully rigid attachment) should be used for the mounting of this sub-frame.

Consult DAF for the selection of the sub-frame section.

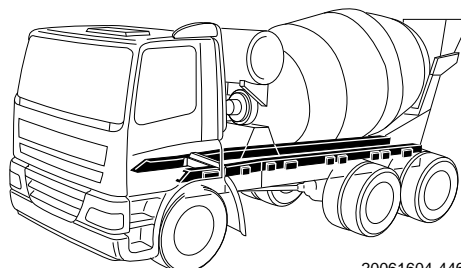

20061604-446

Concrete mixer superstructure

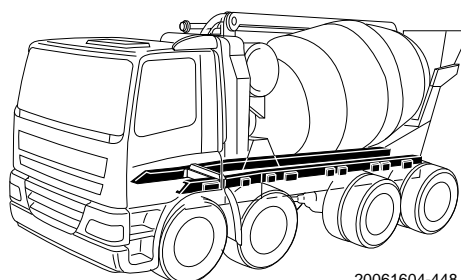

20061604-448

Concrete pump superstructure

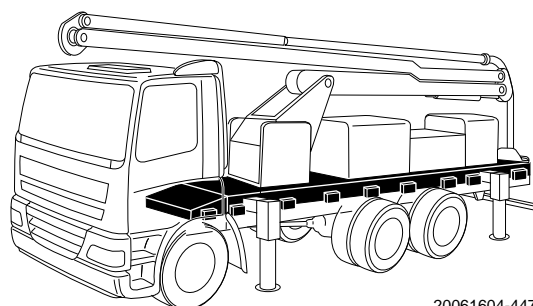

20061604-447

Combined concrete mixer/ concrete pump superstructure

Torsional stability

In all cases torsional stiffeners should be fitted in the rear overhang of the vehicle, in accordance with 'Torsional stability of the sub-frame' in section 3.1: "Superstructure with sub-frame".



WARNING! Vehicle stability during operation of any superstructure system is the responsibility of the bodybuilder and the user. The user should at all times make sure that vehicle stability is guaranteed. It is therefore important that clear instructions for use of the superstructure should be provided by the bodybuilder on or supplied with the vehicle.

For more information see:
1.3: "Verificaton of superstructure"

BODYBUILDERS' GUIDELINES

Superstructures

4.7 PUBLIC UTILITY VEHICLES

There is a wide range of public utility vehicles of advanced designs, often regarded as a machine rather than a piece of transport equipment. The customary attachment methods for the most common superstructures are given below. In case of doubt and/or if you have any technical questions about necessary vehicle adaptations, you should contact DAF.

Refuse collector bodies with a compactor at the rear cause extreme high local load (more than 7500 kg) on the rear overhang of the chassis frame. To support this high load in lateral direction and for torsion, the rear end of the chassis frame must be reinforced with a torsional cruciform type stiffening. See an example of the torsional cruciform stiffening in paragraph 'stability by torsional stiffening of the sub frame' in chapter 3.1: "Superstructure with sub-frame".



NOTE: On special request, an alternative preparation for the FAG refuse collector chassis can be ordered at DAF. This FAG frame, with short rear overhang of 740, 920 or 1000 mm, has a 310x75x7 mm frame with full chassis inner reinforcement profile (295x75x5 mm) and is equipped with a heavy duty cross member at the location of the rear axle. For this alternative chassis is no extra subframe or torsional stiffening required.

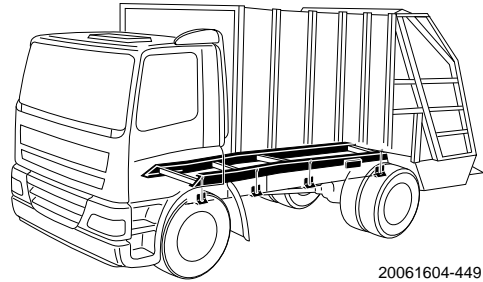

20061604-449

Refuse collector with sub-frame

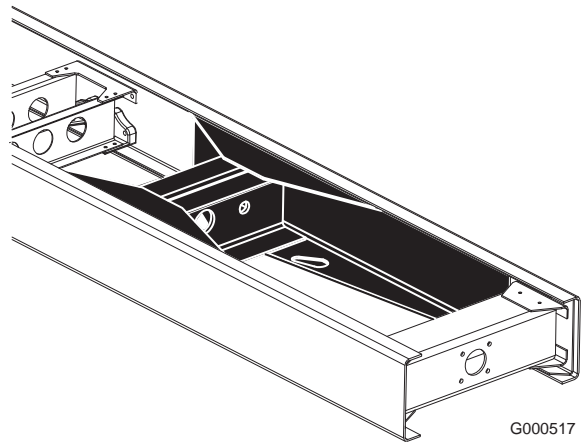

G000517

Heavy duty cross member

Refuse collector with sub-frame

Body attachment method **BAM 1** is used for a refuse collector superstructure with sub-frame. Contact DAF if extremely torsionally rigid constructions are used.

A: 1000 (LF)
1400 (CF - XF)

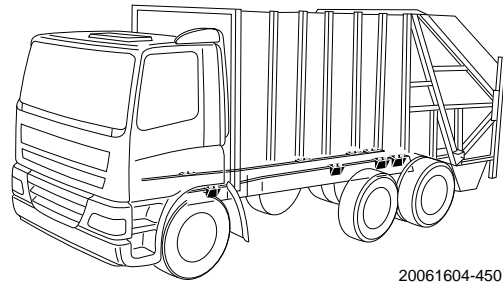

20061604-450

Console attachment

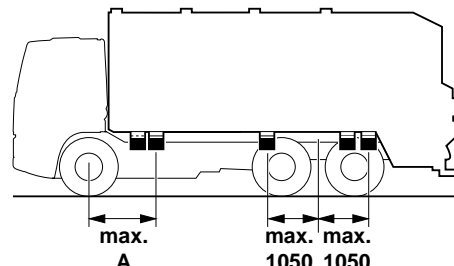

22032802-024

Positions of consoles

Refuse collector on consoles (with or without onboard weighing system)

The console attachment (BAM5) introduces a local vertical point load which results in local stress in the chassis. Therefore the chassis longitudinal must be reinforced with an innerliner and on multi-axle vehicles with rear compacter also a heavy duty cross member is required, in case that there are no inner reinforcements a subframe must be mounted. The console attachment might also introduce lateral torsion to the chassis longitudinal. To eliminate this lateral torsion a cross member must be fitted, on the spot of the console, if not present. Check section consoles in 3.2: "BAM's - body attachment methods".

BODYBUILDERS' GUIDELINES

Superstructures

Body **attachment method BAM 5** is used for this. In relation with a vertical static console load of 20 kN two pressure springs should be used, the pre-tension of each spring should be 3 kN. The minimum spring rate per spring is 225 N/mm. Consoles with pressure springs are used at the front. Spring pre-tension should be 3 kN per spring. Fixed superstructure-to-console-attachment is used at the rear. For this, use spacer bushes with a length of at least 30 mm (see section 3.4: "Type of superstructure/BAM matrix").

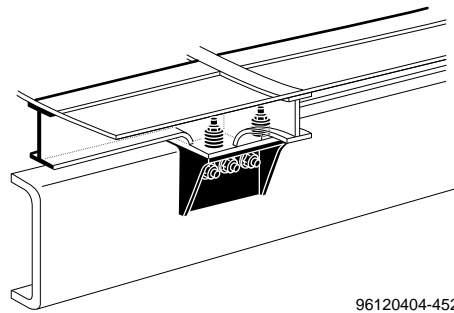

Console with pressure springs

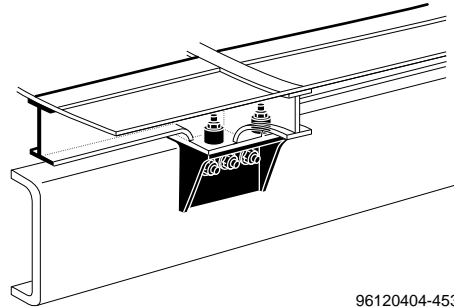

Console with fixed attachment

Refuse collector with rotating drum

Always use a sub-frame and sufficient attachment plates to mount the superstructure to the chassis, in accordance with **body attachment method BAM 4**.

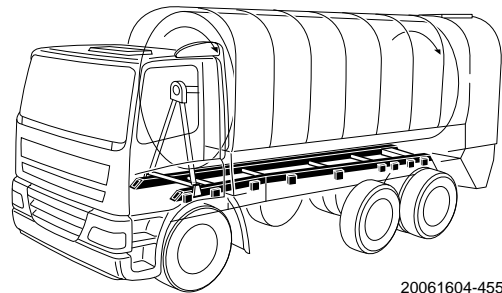

Refuse collector with rotating drum

Road sweeper

The superstructure should always be fitted with a sub-frame and in accordance with **body attachment method BAM 1**. However, use **BAM 3a** for a tipping road sweeper superstructure. See section 4.4: "Tipper bodies" for the required sub-frame dimensions.

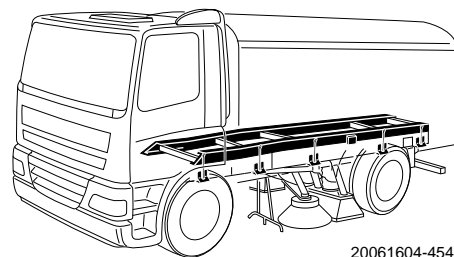

Road sweeper with sub-frame

(Tipping) gully emptier

The superstructure should always be fitted with a sub-frame and in accordance with **body attachment method BAM 1**. Use **BAM 3a** for tipping superstructure. See section 4.4: "Tipper bodies" for the required sub-frame dimensions. Torsional stiffening must be provided in the chassis rear overhang (in accordance with: 'Torsional stability of the sub-frame' in section 3.1: "Superstructure with sub-frame").



WARNING! Vehicle stability during operation of any superstructure system is the responsibility of the bodybuilder and the user. The user should at all times make sure that vehicle stability is guaranteed. It is therefore important that clear instructions for use of the superstructure should be provided by the bodybuilder on or supplied with the vehicle. For more information see: 1.3: "Verificaton of superstructure"

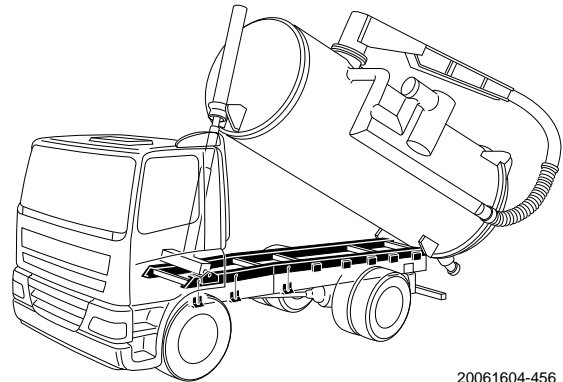

(Tipping) gully emptier

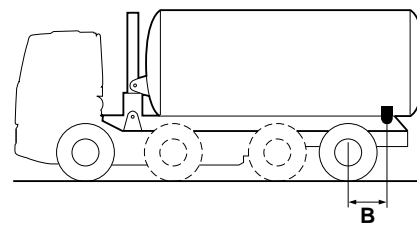

Position of tipper pivot point

4.8 FRONT MOUNTED EQUIPMENT

Front mounting area CF75-85 and XF Series

The front mounting equipment is commonly fitted to a mounting plate according DIN 76060. The vehicle front mounting area has two attachment points on each chassis side member. The attachment points at the chassis are:

- Upper part mounted to the towing lugs (one on each side).
- Lower part mounted to two area's on the FUP (Front Underrun Protection) beam frontal surface.

For the upper part; It is advice to take the diameter dimensions of the fixation pen towing lug, as supplied in the toolbox, to ensure a rigid and close tolerance fit. For the lower part of the front mounting construction, the reinforced sections on the FUP beam must be used. These are the grey marked area's (see illustration) directly in front of the left and right hand leaf spring (or air suspension) hanger bracket. Welding brackets or studs onto the FUP is not allowed. Due to pulling forces (i.e. towing) the fixation brackets should preferably (partly) enclose the FUP beam at the appointed fixation points.

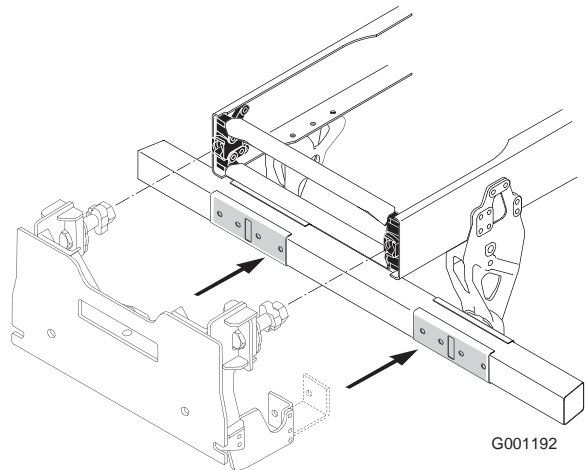

Example of installation of front mounting equipment.

BODYBUILDERS' GUIDELINES

Superstructures

The maximum load and distance allowed for a construction suspended as illustrated in the image are:

G: 15 kN

a: 1200mm



NOTE: The front mounting equipment must comply with regulation ECE R61 and/or directive EC 92/114 external protection of cabs. For equipment supporting DIN brackets that have an integrated towing lug construction the maximum permitted weight of a towed vehicle (including load) is 40 tons. Towing may not take place at an angle larger than 20° with the vehicle centre line.

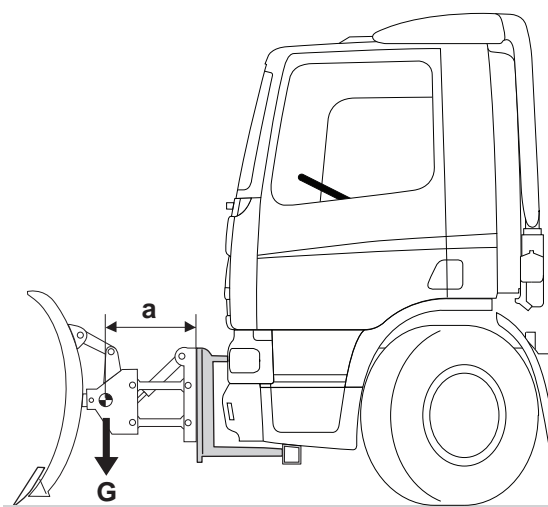

G001189

4



NOTE: All information applies to CF 75 - 85 and XF series produced from respectively 2009 wk 49 and 2009 wk 21 onwards. Chassis produced before these dates require a reinforced support at the front (replacing the standard) and an extra at the rear of the FUP beam reaching towards the chassis main longitudinal. Contact DAF if in doubt.



WARNING! Operation of any superstructure system is the responsibility of the bodybuilder and the user. It is therefore important that clear instructions for use of the superstructure should be provided by the bodybuilder on or supplied with the vehicle.

For more information see:
1.3: "Verificaton of superstructure"

4.9 FIFTH WHEEL

DAF tractor chassis are provided with angle sections for simple fifth wheel mounting. For optimum utilisation of tractor/semi-trailer combinations, it is highly important that the technical specifications of tractor chassis and semi-trailer should be carefully matched. Only then will it be possible to determine the correct position of the fifth wheel (**KA** dimension) and the correct fifth wheel mounting height (**HK** dimension).

To ensure quality and durability of the entire construction, only fifth wheels and base plates released by DAF must be mounted.

Mounting height and freedom of movement

Because of the required **freedom of movement** for the semi-trailer, the **fifth wheel** mounting height is determined by a number of factors:

- A semi-trailer coupled to a tractor should, in the straight-ahead position, have enough freedom of movement to move 6° forwards, 7° backwards and 3° to each side (taken from ISO standard R 1726).
- When turning, the front corners of the semi-trailer must not touch the rear wall of the cab. Swing clearance should be at least 200 mm. This minimum clearance is highly dependent on components on the rear wall of the cab, such as the air intake system, the exhaust and accessories that have been fitted. To meet the minimum requirement, it may be necessary to relocate the bracket for lighting and air connections.
- During manoeuvring, the semi-trailer must not touch any parts of the tractor chassis, such as mudguards, brackets or lamps. The minimum fifth wheel mounting height above the chassis is also determined by the height of the tyres above the chassis with the springs bottoming (metal on metal). In the case of FTS, FTP and FTG tractors, the wheel clearance of the lifted rear steered axle or second axle should also be taken into account. Also see section 2.14: "Wheel clearance".
- On high-volume semi-trailers used in combination with low-fifth wheel tractor chassis, there should always be a clearance of at least 160 mm between the top of the chassis side members and the underside of the semi-trailer to allow manoeuvring at loading bays, etc. If 3-piece rear mudguards are fitted, it may be necessary to remove the central sections when coupling up the semi-trailer.

For further references concerning the freedom of movement for the semi-trailer, also see ISO standard R 1726: 1989 E.

BODYBUILDERS' GUIDELINES

Superstructures

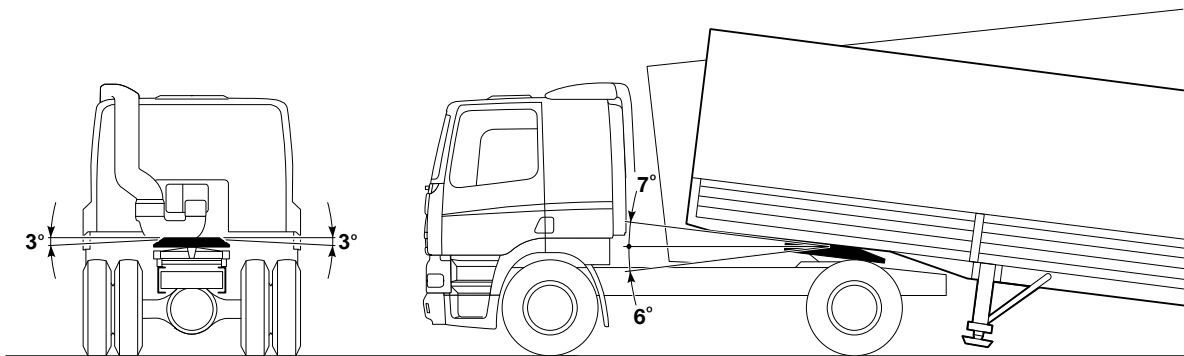

G000305

Required freedom of movement

4

D value of fifth wheel

The D value is defined as the theoretical reference value for the **horizontal** force between, in this case, the tractor and the semi-trailer and is therefore taken as a basis for the maximum load under dynamic conditions. The formula below (from directive EC 94/20) can be used to determine the minimum D value required for the fifth wheel.

where:

- GA** = Maximum permitted mass (tonnes) of the semi-trailer.
- GT** = Maximum permitted mass (tonnes) of the tractor.
- F** = Maximum permitted vertical mass on the fifth wheel. (tonnes)
- D** = D value on the fifth wheel. (kN)
- g** = Gravitational acceleration. ($\approx 10 \text{ m/s}^2$)

$$D = g \times \frac{0,6 GT \times GA}{GT + GA - F} \text{ [kN]}$$

SE0004

Fifth wheel and base plate

The following guidelines apply to the mounting of the fifth wheel and base plate:

- For the mounting of the fifth wheel, only use a fifth wheel base plate released by DAF, which has been tested **as a part of the vehicle** and is mentioned as such in the vehicle certificate. Various separate base plates are also available from DAF. See section 13.13: "Miscellaneous parts" for the available DAF part numbers'.
- The pre-drilled base plates should be fitted to the angle sections on the chassis, using at least **12***bolts. Only the use of **M16x2 flange bolts**(property class 10.9) is permitted. The bolt heads should point downwards to enable visual inspection. The holes in the pre-drilled angle sections have a pitch of 50 mm. Turning the DAF base plate through 180° (see section 13.13: "Miscellaneous parts" for the available DAF part numbers), gives fifth wheel position adjustment steps of

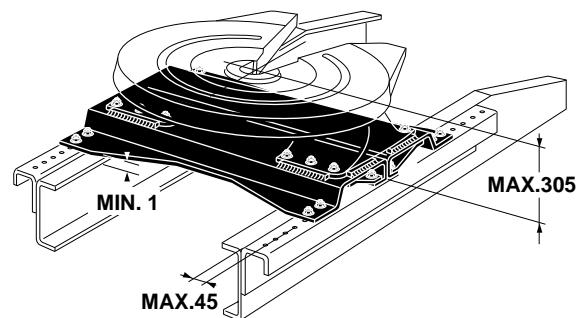

G000292

Mounting of the base plate

25 mm. As a result, simple adjustment of the fifth wheel position (within the maximum and minimum KA dimension) is possible, within the limits of the maximum permitted axle and or chassis loads.

- * To a maximum fifth wheel load of 20 tonnes. For the 12 mm base plate the use of 8 bolts is sufficient up to a maximum fifth wheel load of 15 tonnes.
- The maximum permissible mounting height of fifth wheel and base plate is $H = 305 \text{ mm}$
- To prevent the bolts working loose, **two attachment bolts** should be used at each of the four corners of the base plate. If base plates are used on which only one attachment bolt can be fitted at each corner, 40 mm spacer bushes (combined with longer flange bolts) must be fitted under the bolt heads.
- The maximum distance between the outside of the chassis frame and the attachment bolts in the (non-pre-drilled) angle sections is 45 mm
- The minimum clearance between underside of the base plate and the top of chassis side member flanges is always 1 mm.
- Preferably use two-piece base plates for applications involving frequent manoeuvring and off-the-road operation.
- The DAF base plates with a height of 80 and 120 mm are therefore two-piece plates as standard.
- The fifth wheel should be fitted in accordance with the supplier's instructions.

For the tightening torques of DAF flange bolts, see the table in section 2.6: "Attachment of components to the chassis".

Catwalk

If a catwalk is fitted, it must be attached to the chassis frame with rubber mounts. Make sure that sufficient clearance is left for the semi-trailer under all circumstances.



WARNING! Operation of any pump or superstructure system is the responsibility of the bodybuilder and the user. It is therefore important that clear instructions for use of the superstructure should be provided by the bodybuilder on or supplied with the vehicle.

For more information see:
1.3: "Verificaton of superstructure"

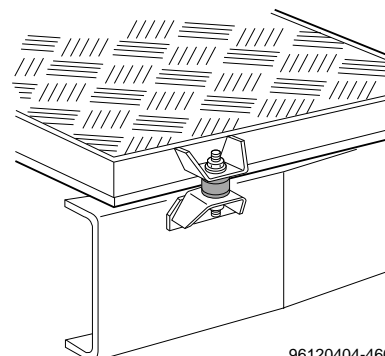

96120404-460

Mounting of catwalk

BODYBUILDERS' GUIDELINES

Superstructures

4

CAB INFORMATION

	Page	Date
5.1 Cab modification	137	201019
5.2 Maximum permissible additional cab weights	137	201019
5.3 Accessories mounting positions	142	201019
5.4 Setting the roof spoiler.	149	201019

BODYBUILDERS' GUIDELINES

Cab information

5

5. CAB INFORMATION

5.1 CAB MODIFICATION

No modifications must be made to the cab design, the cab location or the cab suspension without prior written permission from DAF. Because of the special hardening process used, no welding is allowed on the main chassis members of the cab.

If holes have to be drilled in the chassis, make sure they are free from burrs, that rust prevention measures are taken and that the holes are adequately blanked with grommets or sealer.



WARNING! *The truck cab must always first be fully tilted forward (up to the mechanical lock) before work is carried out under it. In all other cases, the bodybuilder should provide a separate locking device using a support.*

5.2 MAXIMUM PERMISSIBLE ADDITIONAL CAB WEIGHTS

Information about the maximum weight that may be added to a cab, and about any consequences of adding weight, is given below for the different vehicle series. For additions of higher weights, please consult DAF.

DAF LF Series

Maximum additional cab weight [kg]		
Location of added weight	Day cab	Sleeper cab
On the roof, supported on the M8 welded nuts	40	40
On the roof, supported on the cab walls (see also subject "Mounting of top sleeper on LF Series cab" below)	150	150
Evenly distributed over the under-bunk storage compartments	-	50
Evenly distributed over the bunk	-	125 ⁽¹⁾
In the storage compartments over the windscreen	5 ⁽²⁾	5 ⁽²⁾

(1) Static situation and stationary vehicle.

(2) Total weight distributed over the total storage surface of the compartments.

BODYBUILDERS' GUIDELINES

Cab information

Mounting of top sleeper on LF Series cab

The existing cab suspension is designed for cab versions with spoilers and other approved cab accessories. If the mounting of a top sleeper is required a chassis with reinforced mechanical cab suspension should be ordered ex-factory. The reinforced cab suspension prevents excessive cab movements if additional load is added to the cab roof and the cab tilt angle will be limited to 45°.

Maximum bunk load

For the sleeper cab, the maximum permitted load on the bunk **during driving** is 25 kg. Consult DAF if this rule has to be departed from.

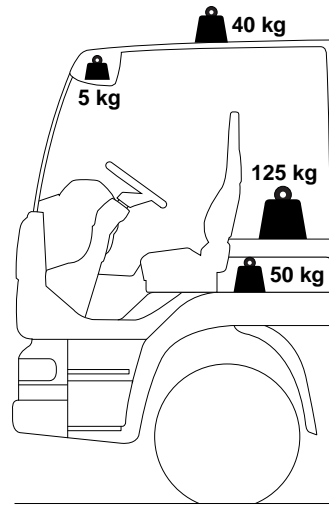

22032802-054

DAF CF Series

Maximum cab weight [kg]

Location of added weight	Day cab	Sleeper cab	SpaceCab
On the roof, distributed over the 4x/6x M10 welded nuts provided ⁽¹⁾	150	150	40
In the storage compartments over the windscreen	15	15	15
In the storage compartments in the SpaceCab roof			20
Evenly distributed over the bunk		150	150
Evenly distributed over the under-bunk storage compartments (cab with high bunk position)		50	50
In the storage compartments left and right of the engine hump		2 x 25	2 x 25
On second bunk, if fitted (stationary vehicle)		100	100
On second bunk, if fitted (bunk folded up and vehicle moving)		50	50

(1) The SpaceCab roof does not have welded nuts. The positions of 8 aluminium blocks are indicated by depressions.

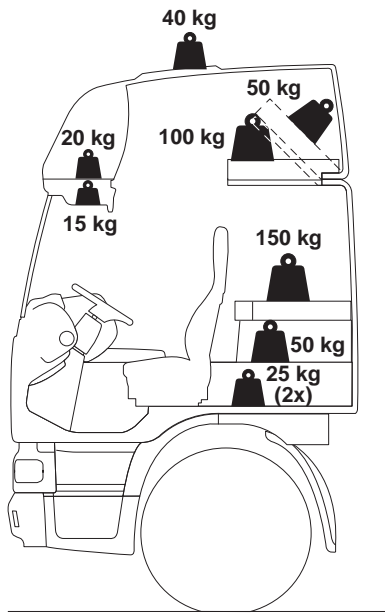

G000563

Load on CF SpaceCab

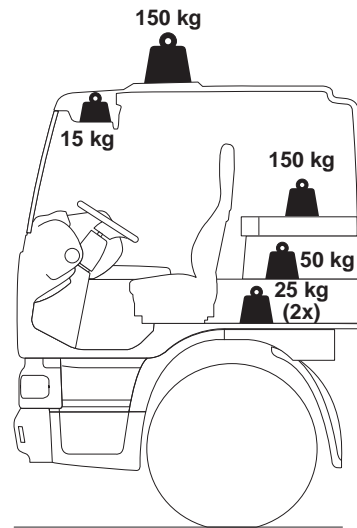

G000564

Load on cabs of CF series

5

Setting the coil springs

The coil springs can be re-set in four steps, the front coil springs in 9 kg steps per coil spring, the rear coil springs in 13.5 kg steps per coil spring. Remove the bumper before re-setting the coil springs at the front.



WARNING! When load is added to the cab, the height of the coil-sprung cab must be checked and, if necessary, the coil springs must be re-set.

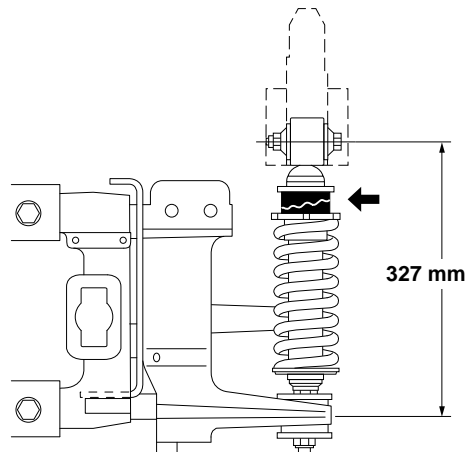

20081102-004

Cab suspension of CF75-85 Series, front

BODYBUILDERS' GUIDELINES

Cab information

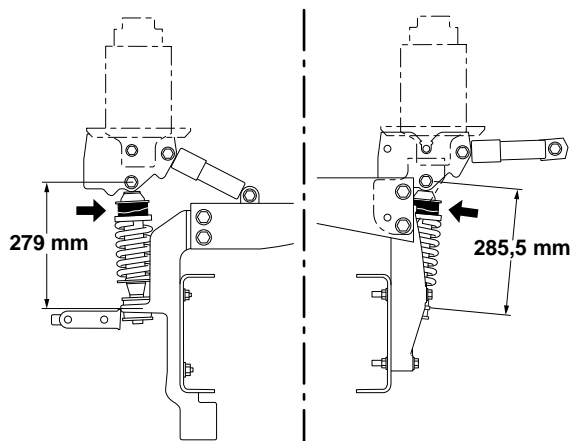

22032802-010

Suspension of CF75-85 series sleeper/day cab, rear

5

Mounting of top sleeper on CF Series cabs

If the mounting of a top sleeper on a short cab is required, DAF should be contacted before the vehicle is ordered. To restrict the cab movements in such a case, all the springs of the cab suspension system have to be replaced or the right version has to be supplied ex-works. For part numbers, see section 13.1: "Mountings". Setting the coil springs for extra load is described above.

DAF XF Series

Maximum additional cab weight ⁽¹⁾ [kg]			
Location of added weight	Comfort cab	SpaceCab	Super SpaceCab
On the roof, distributed over the 4x M10 welded nuts provided	65	65	65
Distributed over the XF storage compartments above the windscreen	2 x 15	25 + 40 + 15	15 + 50 + 15
Maximum load in the XF open storage compartment under the centre compartment above the windscreen	-	-	10
Evenly distributed in the XF storage compartments above each door	-	-	10
Evenly distributed over the lower bunk	150	150	150
In the under-bunk storage compartments	200	200	200
Evenly distributed over the upper bunk	100	100	100
Maximum additional weight			
Coil-sprung cab suspension	300	235	-
Air-sprung cab suspension	480	390	300

(1) Adding more weight to the cab than indicated in the table may reduce the driving comfort.

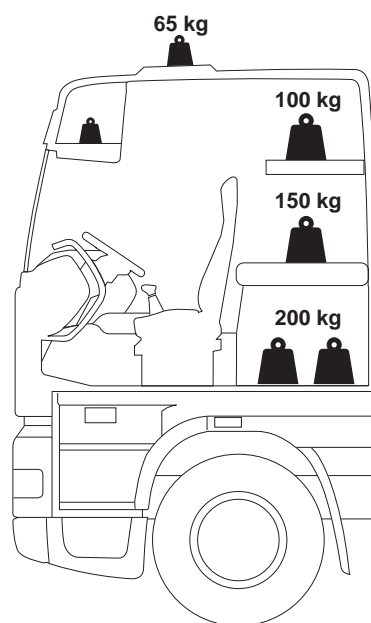

G000565

Load on cabs of XF Series

Setting the coil springs

The coil springs can be re-set in four steps, the front and rear coil springs in 18 kg steps per coil spring. Remove the lower grill to access the coil springs at the front.



WARNING! When load is added to the cab, the height of the coil-sprung cab must be checked and, if necessary, the coil springs must be re-set.

BODYBUILDERS' GUIDELINES

Cab information

5

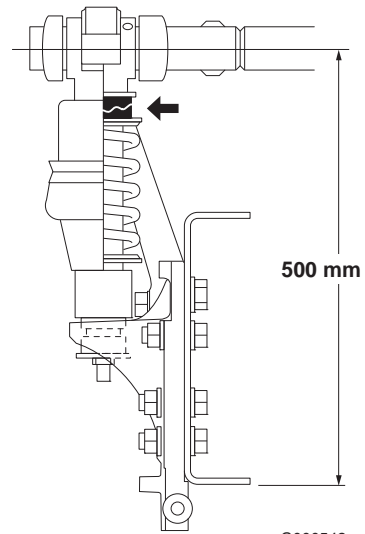

G000542

Cab suspension of XF series, front

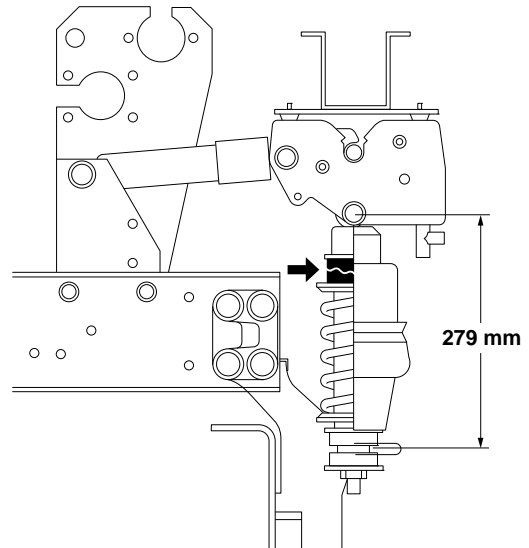

96120404-508

Cab suspension of XF series, rear

5.3 ACCESSORIES MOUNTING POSITIONS

The undermentioned positions may be used for accessories supplied by DAF.

The hole pattern for the XF shown here enables all accessories to be mounted. The holes F and G for aerials are provided as standard.

On all CF and XF cab roofs, the four, six or eight positions (A) for the mounting of the roof spoiler are indicated by dimples in the roof surface. Under these dimples, on the inside of the roof, there are M10 welded nuts or aluminium blocks (CF SpaceCab). For the mounting of spotlights, M8

welded nut or aluminium blocks are fitted on the inside of the roof in the indicated places. However, only the lower four holes are indicated by dimples in the roof surface. The CF SpaceCab roof and the XF Super SpaceCab roof do **not** have dimples at the front.

The LF cab roof panels always have dimples on the outside (only on the top) to indicate welded nut positions, but the welded nuts themselves are not always fitted. The following applies if the chassis number is lower than 0L232487: before drilling, always check whether the roof spoiler and/or sun visor mounting frame has been fitted to the inside of the cab roof panel. If this is not the case, the frame should be mounted. The sun visor mounting frame on the inside of the cab roof panel is not fitted as standard. When retrofitting a sun visor, this frame should always be mounted. If in doubt, consult DAF.

BODYBUILDERS' GUIDELINES

Cab information

LF day and sleeper cabs

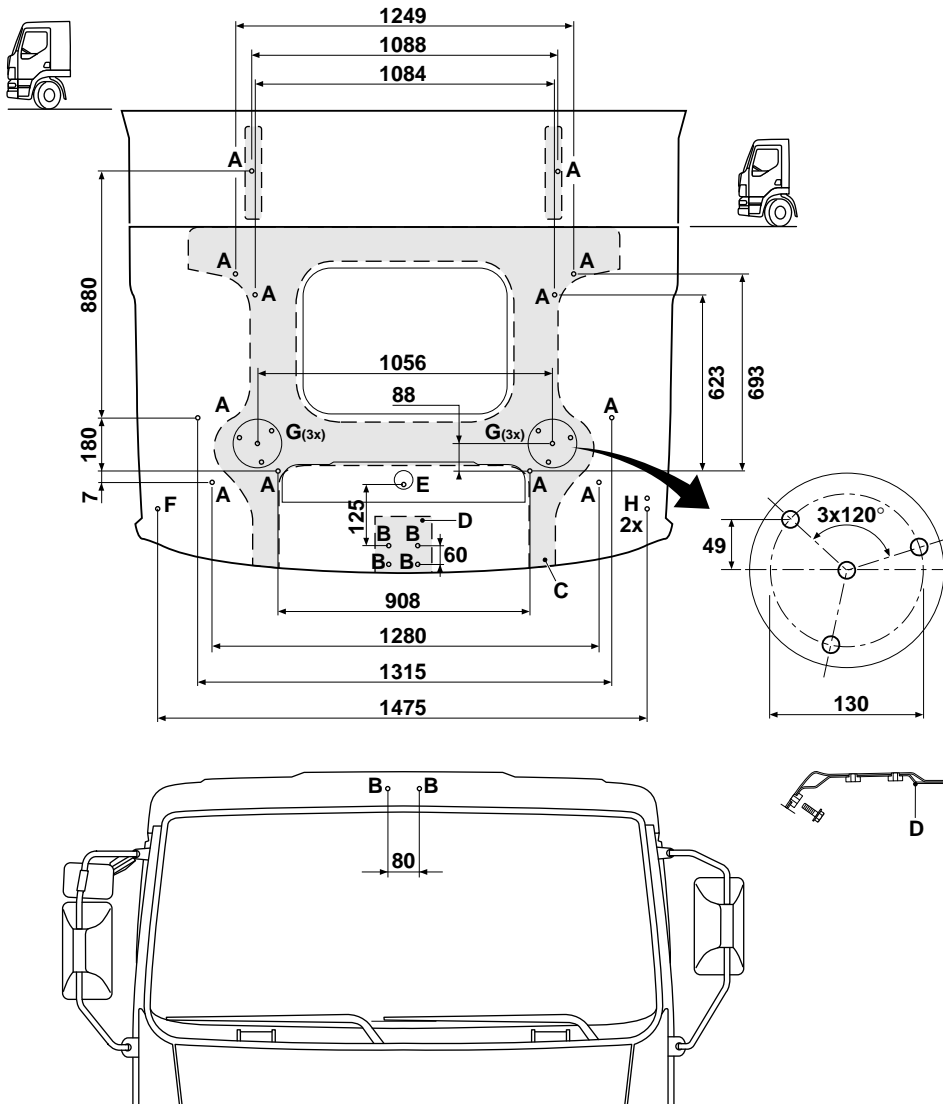

5

G000312

- A: roof spoiler mounting points (4x or 6x M8 welded nut)
 - B: mounting points for sun visor or other accessories (6x M8 welded nut).
 - C: roof spoiler mounting frame + 2x extensions for sleeper cab (mounted as standard as from chassis number: 0L232487)
 - D: centrally positioned mounting frame for sun visor
- Note:**
There are no dimples in the roof panel to indicate the positions of the welded nuts for the sun visor mounting frame; the drilling points can be determined by mounting M8 bolts to the sun visor mounting frame on the interior side of the cab.
- E: radio aerial
 - F: telephone aerial ⁽¹⁾
 - G: beacon ⁽¹⁾
 - H: CB aerial ⁽¹⁾

(1) dimples only; no welded nut nor reinforcement plate on inside of roofpanel. Additional dimples at the G (lefthand side only) and H location are to be used for wire lead trough.

CF day and sleeper cabs

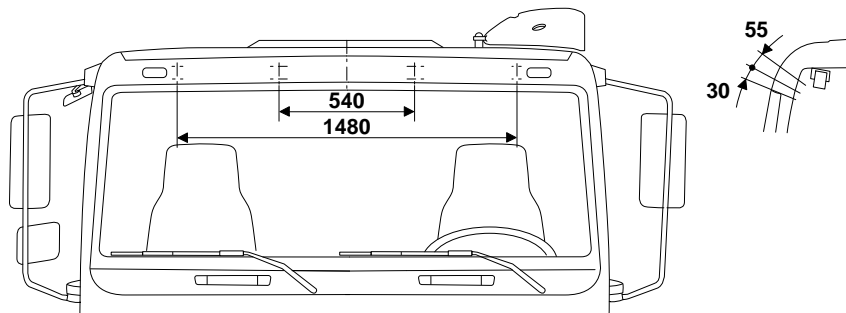
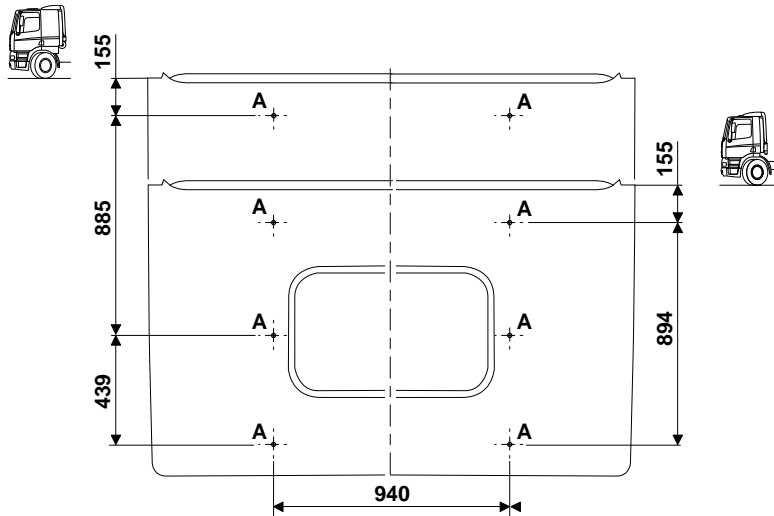

A: roof spoiler mounting points (4x or 6x M10 welded nut)

20090503-020

BODYBUILDERS' GUIDELINES

Cab information

CF Space cab

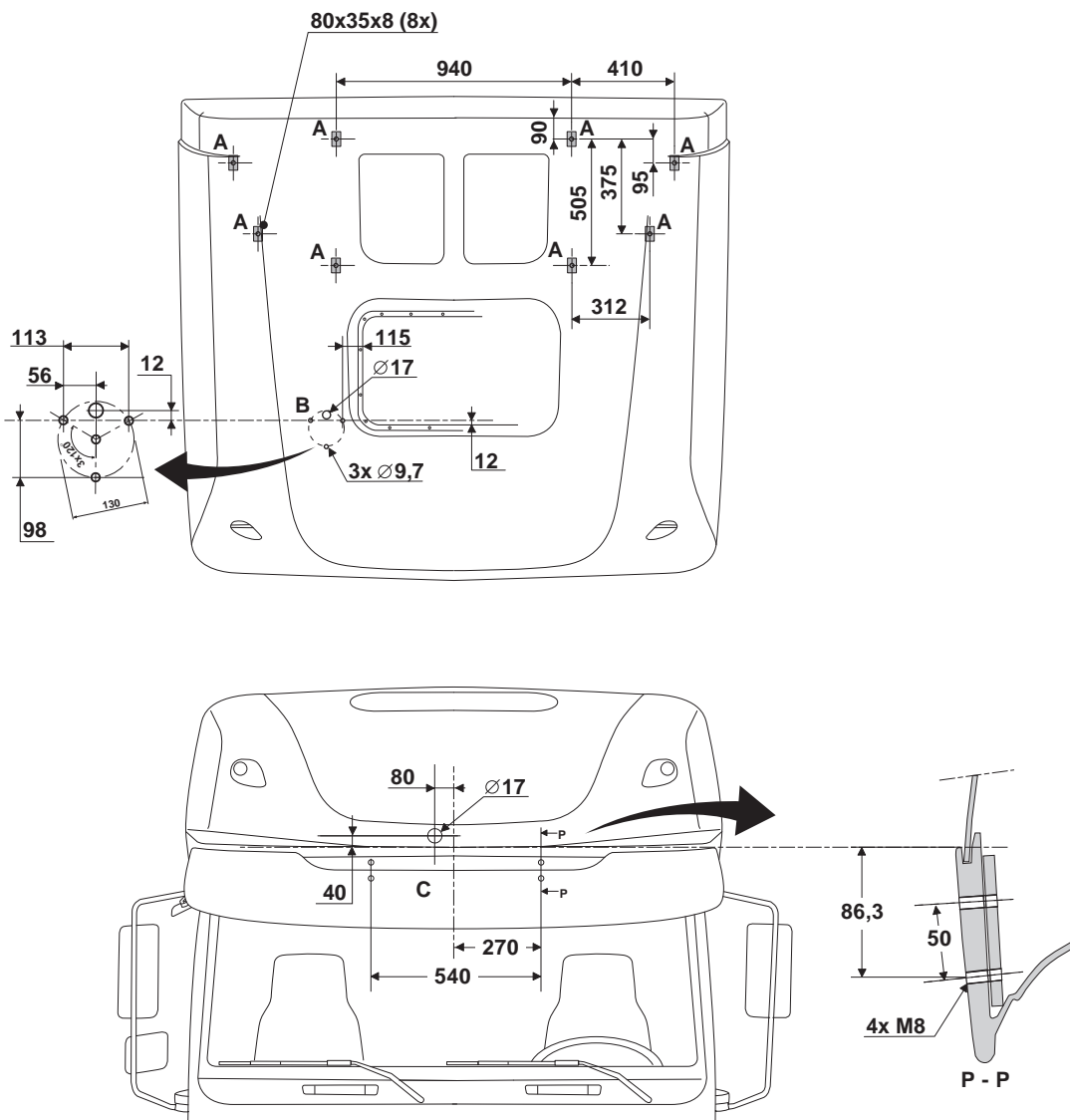

- A: roof spoiler mounting points (8x aluminium block).
- B: flashing beacon mounting points righthand side (mirror image for left hand side mounting).
- C: spotlight bracket mounting points.



NOTE: No dimples at front of SpaceCab roof.



NOTE: Distances for mounting frame for DAF sun visor and spotlights are measured from the edge at the front of the SpaceCab.

G001155

XF Comfort cab

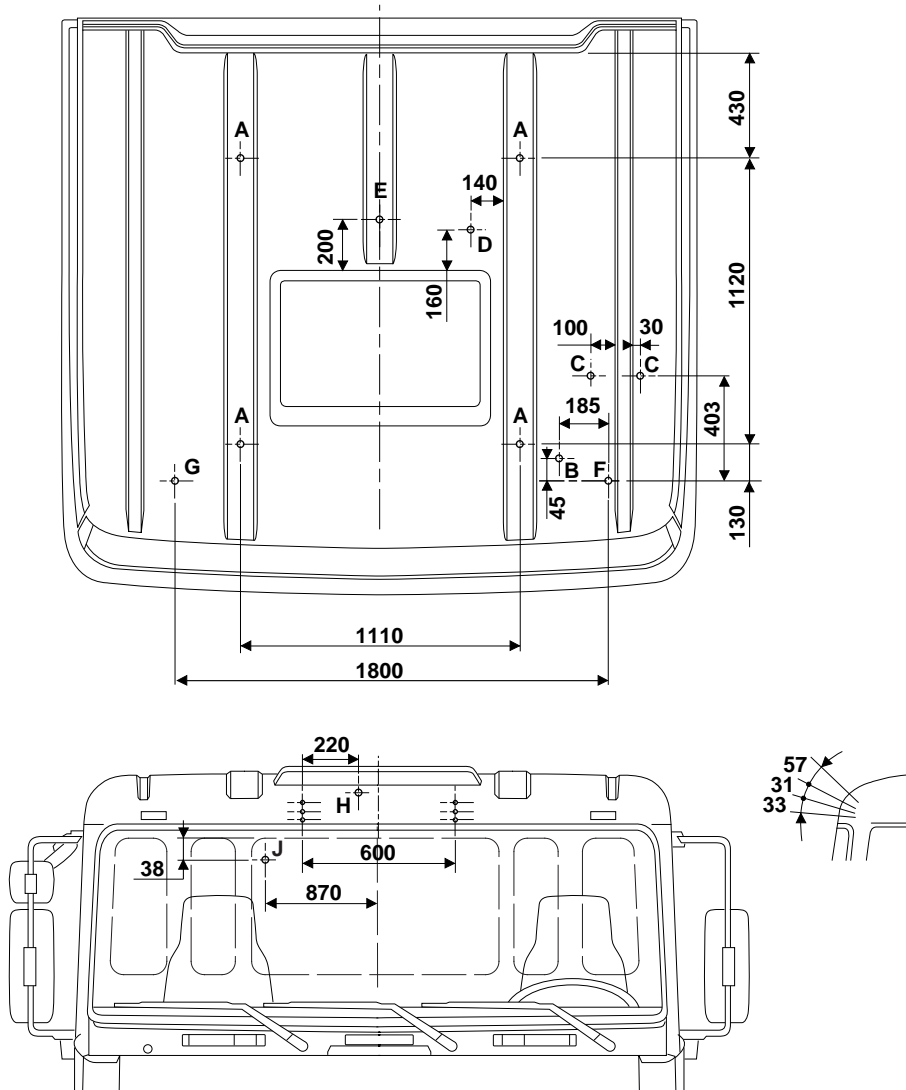

LHD version drawn

G000396

- A: roof spoiler
- B: wire lead-through hole for rotating beam ⁽¹⁾
- C: air hose lead-through hole for air horn ⁽¹⁾
- D: satcom aerial (satellite communication)
- E: aerial (MAUT - Toll Collect) ⁽¹⁾ ⁽²⁾
- F: combi aerial (Radio & GSM & GPS) ⁽¹⁾ ⁽²⁾
- G: combi aerial, (Radio & GSM & GPS) ⁽¹⁾ ⁽²⁾
- H: spotlights ⁽¹⁾
- J: CB aerial ⁽²⁾ (against cab rear wall)

(1) RHD mirror image

(2) Hole = rectangular cut out of 15 x 15 mm (from May 2004 onwards)

BODYBUILDERS' GUIDELINES

Cab information

XF Space cab

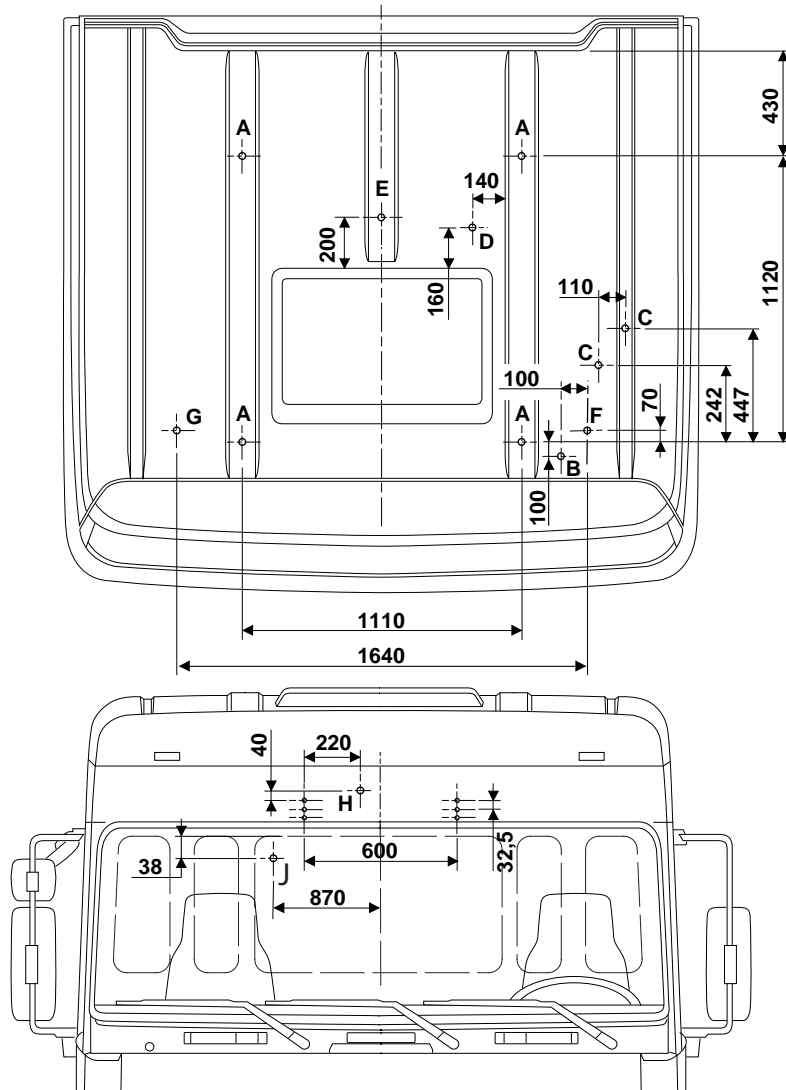

G000397

LHD version drawn

- A: roof spoiler
- B: wire lead-through hole for rotating beam ⁽¹⁾
- C: air hose lead-through hole for air horn ⁽¹⁾
- D: satcom aerial (satellite communication)
- E: aerial (MAUT - Toll Collect ⁽¹⁾ ⁽²⁾)
- F: combi aerial (Radio & GSM & GPS) ⁽¹⁾ ⁽²⁾
- G: combi aerial (Radio & GSM & GPS) ⁽¹⁾ ⁽²⁾
- H: spotlights ⁽¹⁾
- J: CB aerial ⁽²⁾ (against cab rear wall)

⁽¹⁾ RHD mirror image

⁽²⁾ Hole = rectangular cut out of 15 x 15 mm (from May 2004 onwards)

5.4 SETTING THE ROOF SPOILER

To improve the aerodynamics of a vehicle which has a superstructure higher or wider than the cab, DAF developed roof spoilers with extensions and rear air foils for all its vehicles.

The use of these spoilers can reduce fuel consumption considerably, but the quantity of fuel saved is highly dependent on the number of aerodynamic aids fitted, the shape of the superstructure and the driving conditions.

A correct roof spoiler height is always essential. It can be established as follows:

- Determine the symmetry line of the vehicle. Place a slat on the roof of the superstructure. It should protrude from the superstructure roof in the direction of the cab.
- Place a second slat, as a tangent, on the top edge of the roof spoiler (P). It should point in the direction of the superstructure.
- The intersection point of the two slats should be at the middle of the distance between the roof spoiler edge and the front end of the superstructure.

This setting procedure applies to roof spoilers with and without extensions and also to the basic roof spoiler, the larger part of which has an open construction.

The desired roof spoiler height can be set using setting device (B). See the table below for the setting range of the roof spoilers for the various cab versions.

Setting range for 'aerodynamic' roof spoiler [mm]

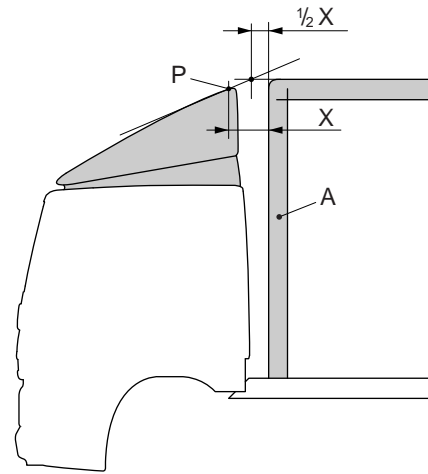

20090503-026

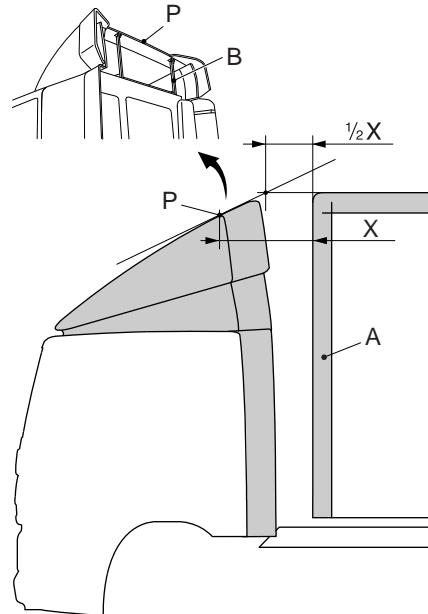

22032802-026

LF	CF	XF	(1)
540 - 770	760 - 1040	nvt	Day cab
540 - 770	760 - 1060	630 - 810	Sleeper Cab (LF-CF) Comfort Cab (XF)
-	215 - 340	370 - 515	Space Cab

(1) Distance measured between the top edge of the roof spoiler (P) and the vehicle centre line on the cab roof panel.

Adjustments can be made in steps of:

- 45.5 mm (7x) for CF day/sleeper cab
- 26 mm (5x) for the CF SpaceCab
- 36 mm for the XF cab (4x for SpaceCab, 5x for Comfort cab).

BODYBUILDERS' GUIDELINES

Cab information

The non-adjustable aerodynamic roof spoilers for the day and sleeper cabs of the LF vehicle series have a fixed height of either 600 mm (day cab only), 900 mm or 1100 mm.

Basic roof spoiler

Setting range for basic roof spoiler [mm]

Series	Day and sleeper cabs ⁽¹⁾
LF	560 to 800
CF	525 to 775

(1) Distance measured between the top edge of the roof spoiler (P) and the vehicle centre line on the cab roof panel.

Mounting instructions are supplied with the DAF roof spoilers or can be found in the RAPIDO documentation system.

5

Shape of the superstructure

In addition to the improvement that can be achieved with aerodynamic aids on the cab, a substantial reduction in air drag can be realised by a superstructure with rounded corners (A) and/or side skirts.

The reduction in air drag results from a 'better' flow of air from roof spoiler and/or rear air foils to the front of the superstructure, and also from a reduced vacuum at the rear of the superstructure (provided there are rounded corners there, too). The feasible reduction in fuel consumption is always dependent on the (aerodynamic) shape of the superstructure and the vehicle's driving conditions.

PTO AND OTHER ENERGY CONSUMERS

	Page	Date
6.1 General	154	201019
6.2 Power take-offs (PTO's)	156	201019
6.3 PTO specification, general	157	201019
6.4 Clutch-independent PTO	164	201019
6.5 Clutch-dependent PTO	172	201019
6.6 First PTO	173	201019
6.7 Second PTO	184	201019
6.8 Transfer box	185	201019
6.9 PTO operation	186	201019
6.10 Compressed air system	187	201019
6.11 Air feed, tipper preparation	190	201019
6.12 Heating system	191	201019

BODYBUILDERS' GUIDELINES

PTO and other energy consumers

6

6. PTO AND OTHER ENERGY CONSUMERS

BODYBUILDERS' GUIDELINES

PTO and other energy consumers

6.1 GENERAL

The vehicles of the DAF range can be supplied with the following gearboxes.

Overview of ZF ⁽¹⁾ gearboxes							
Type	Ratios	LF45	LF55	CF65	CF75	CF85	XF105
S5-42	4.65 - 0.77	■					
	5.72 - 0.76	■					
6S700	6.02 - 0.79	■					
6S800	6.58 - 0.78	■	■	■			
6S1000	6.75 - 0.78	■	■	■			
6AS700	6.02 - 0.79	■					
6AS800	6.58 - 0.78	■	■				
6AS1000	6.75 - 0.78	■	■	■			
9S1110	12.73 - 1.00				■		
	9.48 - 0.75				■		
9S1310	9.48 - 0.75				■		
8S1620	13.80 - 1.00				■		
16S1620	16.41 - 1.00				■		
8S1820	11.54 - 0.84				■	■	
16S1820	13.80 - 0.84				■	■	
16S1920	16.41 - 1.00					■	
16S2020	16.41 - 1.00					■	■
8S2220	11.54 - 0.84					■	
16S2220	13.80 - 0.84					■	■
16S2320	16.41 - 1.00					■	■
16S2520	13.80 - 0.84					■	■
12S2150	15.57 - 1.00				■	■	■
12S2330	15.57 - 1.00					■	■
12S2830	15.57 - 1.00					■	■
12AS1220	12.79 - 1.00				■		
12AS1420	12.79 - 1.00				■		
	10.37 - 0.81				■		
12AS1620	10.37 - 0.81				■		
12AS1630	15.86 - 1.00				■		
12AS1930	15.86 - 1.00					■	
	12.33 - 0.78				■	■	
12AS2130	15.86 - 1.00					■	■
	12.33 - 0.78					■	■
12AS2330	15.86 - 1.00					■	■
	12.33 - 0.78					■	■
12AS2530	12.33 - 0.78					■	■

Overview of ZF ⁽¹⁾ gearboxes							
Type	Ratios	LF45	LF55	CF65	CF75	CF85	XF105
12AS2540	15.86 - 1.00					■	■
	12.29 - 0.78					■	■
16AS2630	14.12 - 0.83					■	■

(1) Criteria for selecting the gearbox are the type of vehicle, engine output, rear axle (ratio) and possibly the specific application. ZF offers several versions, which on the basis of these criteria are used in DAF's different vehicle series. Always check what specific gearbox version is fitted and what range of ratios it has, for instance by referring to the type indication plate on the gearbox.

Overview of gearboxes							
Type	Ratios	LF45	LF55	CF65	CF75	CF85	XF105
ALLISON gearbox							
2500 Series	3.51 - 0.74	■					
3000 Series	3.49 - 0.75		■	■	■		
	3.49 - 0.65				■		
3200 Series	3.49 - 0.75				■		
	3.49 - 0.65				■		
3500 Series	4.59 - 0.75				■		
	4.59 - 0.65				■		
EATON gearbox							
6309	12.57 - 1.00		■	■			
8309	12.57 - 1.00		■	■			



NOTE: On the vehicles of the **LF, CF and XF series**, the centre line of the gearbox **coincides with** the centre line of the vehicle.



NOTE: The description used in Sprint differs from the description used by the gearbox suppliers.

ZF gearboxes

The first digit(s) indicate the number of gears, 6 - 8 - 9 - 12 or 16 speed

The following letter(s) indicate S = manual gearbox, and AS = AS-Tronic gearbox.

The remaining four digits indicate the gearbox series

Eaton gearboxes

The first two digits indicate the gearbox series.

The last two digits indicate the number of gears, 6 or 9 speed

Allison gearboxes

5-speed automatic with overdrive ratio 0.75:1

BODYBUILDERS' GUIDELINES

PTO and other energy consumers

6-speed automatic with overdrive ratio 0.65:1

6.2 POWER TAKE-OFFS (PTO'S)

When energy required for the superstructure is taken from the vehicle, a PTO is used in most cases. Furthermore, there are various possibilities for connections to, for instance, the electrical system of the vehicle. DAF vehicles can ex-works be supplied with provisions for various extra energy consumers. The following provisions are supplied by DAF or can after delivery be added by the bodybuilder.

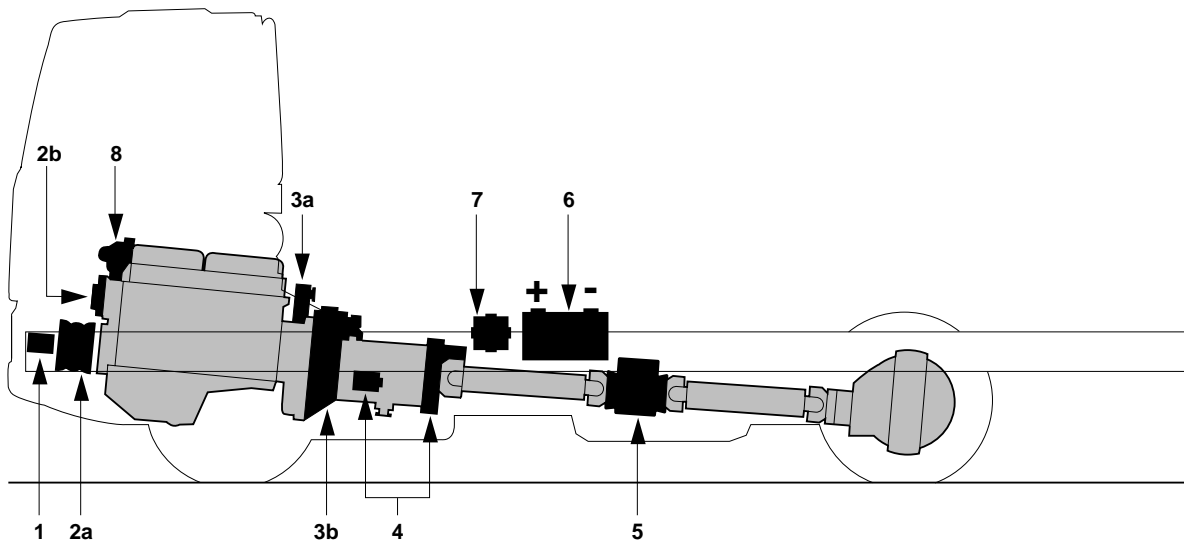

G000293

- 1 = Front-end PTO, direct (LF series only)
- 2a = Front-end PTO, indirect, crankshaft pulley
- 2b = Front-end PTO, indirect, generator-driven
- 2c = Front-end PTO, indirect, for hydraulic pump
- 2d = Front-end PTO, indirect, coolant pump pulley
- 3a = DAF engine PTO
- 3b = Flywheel PTO (ZF)
- 4 = Gearbox PTO
- 5 = Transfer case PTO
- 6 = Electrical system connection
- 7 = Compressed air system connection
- 8 = Engine cooling system connection



NOTE: For electrical system connections, see chapter 9: "Electrical system LF series".

Type of superstructure/energy supply matrix

Application	Energy suppliers											
	1	2a	2b	2c	2d	3a	3b	4	5	6	7	8
Air conditioning		■			■					■		
Vehicle loading crane								■				
Concrete mixer	■					■						

Energy suppliers												
Application	1	2a	2b	2c	2d	3a	3b	4	5	6	7	8
Concrete pump	■					■	■	■	■			
Bulk compressor								■				
Demountable body system								■				
Generator (alternator)		■	■					■				
High-pressure pump						■	■	■	■			
Hydraulic platform		■						■				
Compactor	■					■		■				
Tipper								■				
Refrigerated/deep-frozen transport		■	■	■	■	■						
Gully emptier	■					■	■	■				
Tail lift										■		
Winch								■		■		
Air consumers											■	
Superstructure heating	■											■
Tanker (for example milk tanker)								■				
Water tender (fire service)							■	■	■			

- 1 = Front-end PTO, direct (LF series only)
- 2a = Front-end PTO, indirect, crankshaft pulley
- 2b = Front-end PTO, indirect, generator-driven
- 2c = Front-end PTO, indirect, for hydraulic pump
- 2d = Front-end PTO, indirect, coolant pump pulley
- 3a = DAF engine PTO
- 3b = Flywheel PTO (ZF)
- 4 = Gearbox PTO
- 5 = Transfer case PTO
- 6 = Electrical system connection
- 7 = Compressed air system connection
- 8 = Engine cooling system connection

6.3 PTO SPECIFICATION, GENERAL

When selecting a PTO, the operating conditions, such as the torque to be transmitted, the engine speed, the direction of rotation of the engine, the duration and frequency of operation, play an important role, as do the occurrence of fluctuating (peak) loads, vibrations and high initial torques.

Another important criterion is whether or not the PTO can or may be **clutch-dependent**. For gearbox PTO's are often preferred because of their price, location and the large number of ratios, which makes them suitable for many applications. DAF also offers engine-dependent PTO's, with connections to the crankshaft on the front (front-end PTO), or to the flywheel housing

BODYBUILDERS' GUIDELINES

PTO and other energy consumers

at the rear (DAF engine PTO or ZF/NMV). An engine-PTO is **clutch-independent** and is mostly used to drive auxiliary units that are operated during driving or shunting. In this section, both PTO types will be dealt with.

If the auxiliary consumer requires high torques, it should be checked whether the engine is capable of delivering the power required at the speed specified. The loss of efficiency between the engine and the auxiliary consumer should also be taken into account.

Finally, various versions are available with an output DIN flange or a pump connection, suitable for direct mounting of a hydraulic pump according to ISO standard 7653 (type D).



WARNING! Engine and driveline must not be impeded in their movements as a result of the installation of a PTO and the auxiliary consumers driven by it.

6

Conditions for use

Engaging of in particular gearbox PTO's should be done while the vehicle is stationary and the engine running at idling speed. After depressing the clutch pedal, wait about 2 to 3 seconds until the gearbox countershaft has fully stopped moving, before engaging the PTO. Gear wheel rattle should always be avoided. After engine speed has been increased to 1000 rpm, you can slowly release the clutch pedal. Minimum engine speed during PTO operation: 1000 rpm.

Vehicles with an AS-Tronic gearbox have an electronic controlled (automatic) engaging procedure which operates according a factory or customer defined parameter setting (software).

Permissible power take off for engine PTOs in combination with an AS-Tronic gearbox is 10% of the engine power with a maximum of 32kW. For engine PTOs in combination with AS-Tronic Lite gearboxes, DAF Sales Engineering should be consulted.

As soon as the PTO and pump have definitively been selected, the maximum power take-off can be calculated on the basis of the torque and power calculation. PTO's can roughly be divided into three classes, namely light, medium and heavy, for short-lasting or intermittent use to continuous operation. See the table below.

Class	Nominal torque T [Nm]	Periods of use ⁽¹⁾
Light	$T < 400$	Intermittent
Medium	$400 < T < 1000$	Continuous
Heavy	$T > 1000$	Continuous

(1) See PTO tables

On the basis of the power requirements and the effective PTO operating time, the PTO selected should be a medium-class PTO (rather than a light-class PTO) if one of the following factors applies:

- Periods of prolonged use; allow for the possibility of gearbox oil temperatures running up too high.
- Shock loads (generally caused by incorrect operation); risk is reduced when a hydraulic drive is used.
- Vibrations; a correct PTO drive can keep vibrations within reasonable limits.
- Extremely high initial torques, due, for example, to the mass inertia of the driven equipment.

Protection

The maximum take-off torques specified for the PTO's supplied by DAF, are based on uniform (vibration-free, non-shock) loads without the occurrence of axial forces. **The maximum initial torques must never be higher than 2 times the value specified in the PTO specifications.** If higher torques may occur, an overload protection device must be mounted in the driveline, in the form of a slipping clutch or a security flange. Furthermore, the clutch should have extra protection to prevent the PTO from being engaged too early. With such protection, the clutch pedal must be fully engaged before PTO operation is enabled. According to the cut-in conditions of the VIC (see section 7.21: 'PTO control/protection'), the VIC only checks whether the clutch pedal has been 'touched' or not. If an N/10 PTO is ordered ex-works, the full clutch protection is always included. Further information can be obtained from DAF.

For the ZF gearbox PTO's the maximum torque specifications in the overviews have been calculated at a PTO speed of 1500 rpm for a nominal service life of 500 hours.

BODYBUILDERS' GUIDELINES

PTO and other energy consumers

Oil temperature

During prolonged PTO operation, the gearbox oil temperature must not rise above 110°C. Temperatures up to 130°C are permissible for brief periods (max. 30 minutes). If necessary (check to be sure!), an extra oil cooler should be fitted on the gearbox. In such cases, consult DAF.

Torque and output calculation

- PTO selection

To be able to select the right PTO, it is necessary to calculate the drive torque (I) on the basis of the desired PTO speed (II) and the required effective output (III), assuming that these data of the driven equipment are known:

- Pump selection

For the selection of the right pump for a hydraulic drive, it is first important to determine the effective pump output (P_e) on the basis of the required pump delivery (IV), the system operating pressure (V) and the efficiency (III).

Subsequently, the PTO drive torque (I) can be calculated for the selection of the PTO on the basis of the above-mentioned data:

Where:

n_{pto}	= rpm of power take off unit	[min ⁻¹]
n_{en-}	= rpm of truck engine	[min ⁻¹]
gine		
rev	= revolution of hydraulic pump shaft	
i	= PTO reduction ratio	[-]
M	= PTO drive torque	[Nm]
P_n	= calculated nominal output	[kW]
P_e	= required effective output	[kW]
C	= specific pump capacity	[cm ³ /rev]
Q	= actually required delivery	[l/min]
p	= hydraulic system operating pressure	[bar]
η	= efficiency: $\eta = \eta_1 \times \eta_2 \times \eta_3 \dots$ etc.	[-]

$$M \text{ [Nm]} = \frac{P_e \text{ [kW]} \times 9552}{n_{pto} \text{ [min}^{-1}\text{]}} \quad (I)$$

$$n_{pto} \text{ [min}^{-1}\text{]} = i \text{ [-]} \times n_{engine} \text{ [min}^{-1}\text{]} \quad (II)$$

$$P_e \text{ [kW]} = P_n \text{ [kW]} / \eta \text{ [-]} \quad (III)$$

$$Q \text{ [l/min]} = \frac{C \text{ [cm}^3\text{/rev]} \times n_{pto} \text{ [min}^{-1}\text{]}}{1000} \quad (IV)$$

$$P_n \text{ [kW]} = \frac{Q \text{ [l/min]} \times p \text{ [bar]}}{600} \quad (V)$$

G000354

Speed Factor

If the calculated load is higher than the maximum permissible load, sometimes a lower-capacity pump is specified. By using a higher-speed PTO with a higher speed factor, and/or a higher engine speed, in general the same delivery and power take-off can be realised, however at a proportionally lower PTO drive torque.

Direct pump mounting

For all gearbox PTO applications where the pump is flange-mounted on the PTO, the following limitation applies, unless stated otherwise in the PTO overviews:

The static moment resulting from the pump weight on the both pump connections on the N.../10 PTO mating surface should in general **not exceed 30 Nm**. For the ZF PTO, types NL/1c, NL/10c, NH/1c, NL/4c and NH/4c the maximum permissible static moment is 50 Nm.

The maximum static moment resulting from the pump weight on the DAF PR Engine PTO mating surface is 40 Nm. The static moment on the MX engine PTO surface is 50 Nm. Allison gearboxes the maximum allow a static moment of 40 Nm. For the LF and CF65 Series the bending moment on the engine PTO housing should not exceed 45 Nm.

If the PTO device generates a larger bending moment than allowed it should be supported by additional mounting brackets or remote mounted elsewhere and driven by a carden shaft.

In some cases, the pump dimensions prove to be restricted by the diameter of the drive flange in combination with the location of the countershaft in the gearbox (which determines the location of the PTO). The clearance between pump and drive flange (or shaft) should therefore always be checked.



WARNING! Incorrect use of the hydraulic system (for instance at unduly high revs) may cause damage to the hydraulic pump and subsequently to the gearbox.



WARNING! The pump shaft should therefore be provided with a high temperature-resistant double seal, with a bleed hole between the two seals, to prevent gearbox oil being sucked in or hydraulic oil getting into the gearbox. Note: this is one of the reasons why DAF no longer uses ZF PTO type N/2c!

In some cases the mounting of a so-called pump adapter is recommended. This adapter is provided with a separate PTO seal and a bleed hole (take note of the higher static moment). The ZF N.../4 PTO has a separate pump bearing, so that in that case the mounting of an adapter is not necessary. At any rate, the pump supplier's instructions should always be consulted.

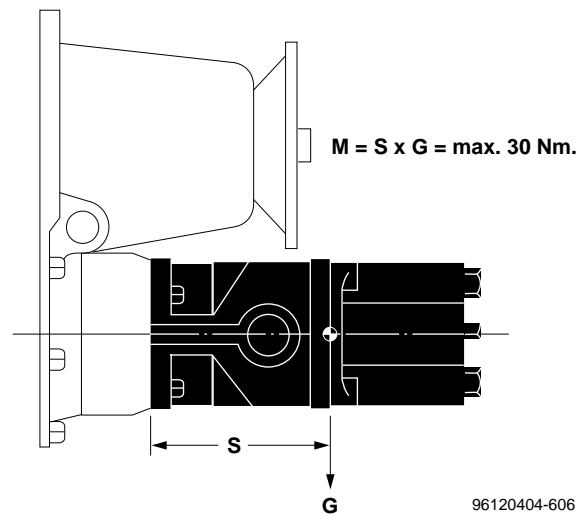

Maximum torque on direct pump connection

96120404-606

BODYBUILDERS' GUIDELINES

PTO and other energy consumers

Drive shafts

The angles formed by the drive shaft couplings between PTO and auxiliary consumer should be equal to each other and should not exceed the following maximum values:

- maximum of 6 degrees for front-end PTO's
- maximum of 8 degrees for all other PTO's

The shafts must be installed in such a way that uniform running of the driven equipment is ensured. This calls for a Z or W arrangement of the shafts. Excessively large drive shaft angles or PTO drive resonance may cause serious vibration far above the calculated (nominal) torques. In case of doubt, tests should always be made before a particular application can be guaranteed.

When the shaft angles (α_1 and α_2) differ from each other, non-uniformity (α_R) will be higher than in the optimum situation, when $\alpha_1 = \alpha_2$. Non-uniformity can be calculated with the formula:

$$\alpha_R = \sqrt{|\alpha_1^2 - \alpha_2^2|}$$

SE0008

where α_R (permissible) $\leq 3^\circ$.

The tools represented by the opposite drawings can be used for the correct alignment of the drive shafts. The sliding joint of the drive shaft on the gearbox should permit a forward movement of at least 8 mm and a rearward movement of at least 5 mm.



WARNING! Ensure that freely accessible drive components are always carefully screened off. Rotating shafts may cause serious injury! Switch OFF the engine before starting operations on the PTO or the PTO drive.

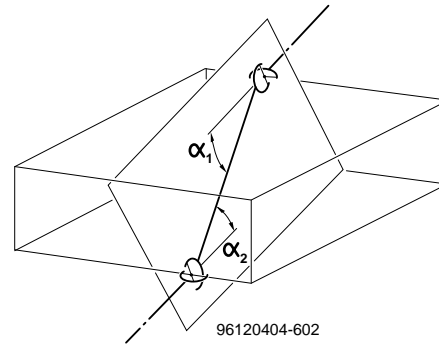

Z arrangement

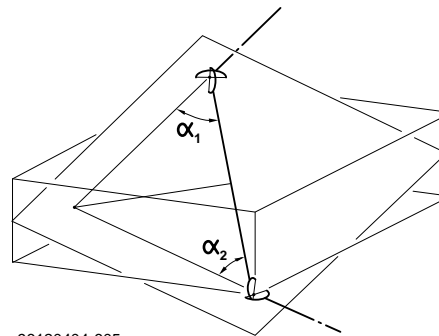

W arrangement

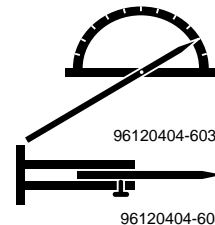

- PTO connections

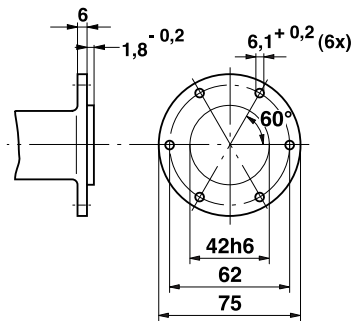

20070604-031

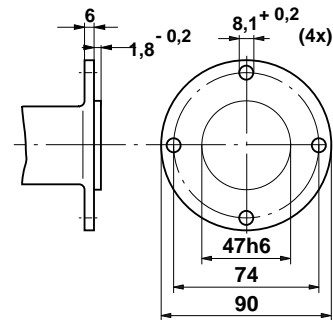

20070604-032

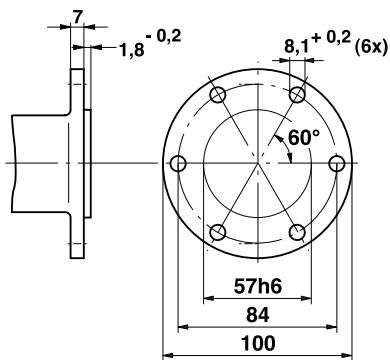

20070604-030

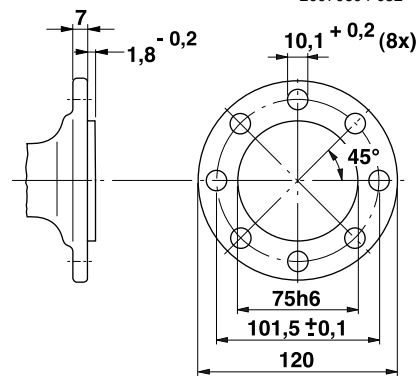

20070604-029

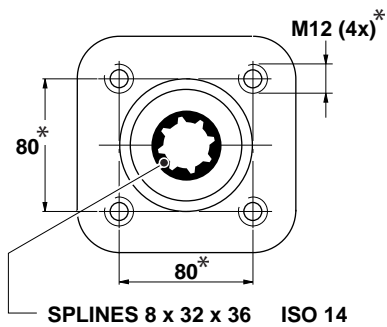

* ISO 7653

G000451-1

Position of engine in the chassis

The angle at which the engine is positioned in the chassis in relation to the chassis side members, designated as: $\angle \alpha$ in the opposite figure, should be:

- LF45/55 and CF65 Series: $\angle \alpha = 3.5^\circ$
- CF75/85 Series: $\angle \alpha = 4.5^\circ$
- XF Series: $\angle \alpha = 4.5^\circ$

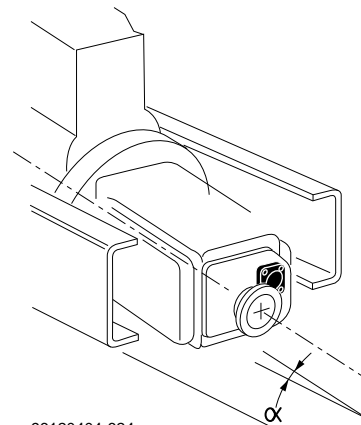

96120404-624a

BODYBUILDERS' GUIDELINES

PTO and other energy consumers

Direction of rotation of the engines

The direction of rotation of the crankshaft of DAF and Cummins engines is always **anti-clockwise**, viewed looking towards the rear of the engine.

6.4 CLUTCH-INDEPENDENT PTO

Front-end PTO, direct

The table below shows the most relevant data with regard to the direct front-end PTO for the LF45 and LF55 vehicle series.

Specifications for front-end PTO, direct		
	LF45	LF55
Angle of engine in relation to chassis side members	3.5°	3.5°
Maximum angles of drive shaft	2 x 6°	2 x 6°
Maximum transmitted torque	250 Nm	250 Nm
Maximum transmitted power	40 kW	40 kW
Maximum added mass inertia	0.2 kgm ²	0.2 kgm ²
Maximum unbalance	100 gmm/kg	100 gmm/kg



WARNING! Any modifications made to bumper or cab tilting system to enable a pump to be mounted, are subject to approval from DAF.

BODYBUILDERS' GUIDELINES

PTO and other energy consumers

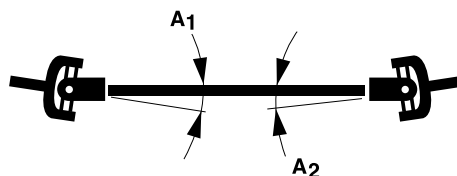

$$A_1 = A_2 = \text{max. } 6^\circ$$

96120404-608

W arrangement of drive shaft

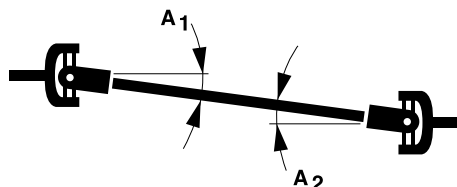

$$A_1 = A_2 = \text{max. } 6^\circ$$

96120404-607

Z arrangement of drive shaft

Installation dimensions, front-end PTO, direct
Based on SAE J1946

Flange location, front-end PTO, direct			
Dimensions: (see figure)	LF45	LF55 12 - 15t	LF55 18 - 19t
Dimension VA	1275	1325	1375
„ A (1)	446	496	636
„ (2)	536	586	636
„ B	932	982	1032
„ C (1)	91	131	136
„ (2)	96	136	136
„ D	145	145	145
„ E	170 x 150	170 x 150	170 x 150
„ F	120	160	160
∠ α	3.5°	3.5°	3.5°
∠ β	3.5°	3.5°	3.5°

- (1) FR engines
(2) GR engines

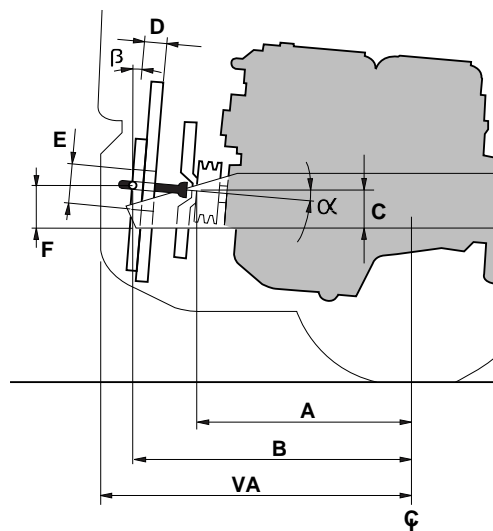

96120404-611

Flange location dimensions, front-end PTO, direct

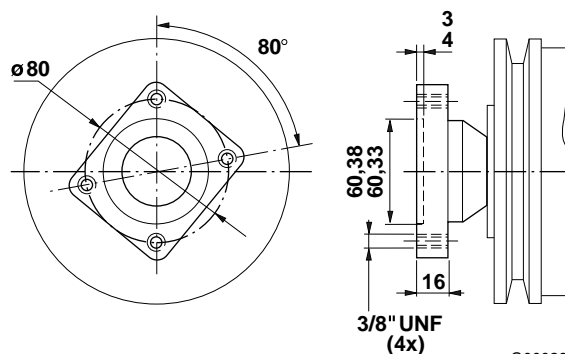

G000290

Flange dimensions, front-end PTO, direct, LF Series

BODYBUILDERS' GUIDELINES

PTO and other energy consumers

Front-end PTO, indirect

Specifications for front-end PTO, indirect				
Vehicle series	LF and CF65	CF75 with airco	CF75	CF85 and XF
Maximum power take-off via coolant pump [kW]: - at engine idling speed - at maximum engine speed	- -	- -	2.2 6	- -
Maximum power take-off via crankshaft pulley [kW]	15	50	50	50
Maximum added mass inertia [kgm ²]	0.2	0.03	0.03	0.05
Maximum unbalance [gmm/kg]	100	125	125	125
Maximum distance between most forward pulley and front of cylinder block [mm]	150	180	180	200
Misalignment (max. 4 mm)	1:120	1:120	1:120	1:120

Any modifications made to engine and chassis are subject to approval from DAF.

- Crankshaft pulley (SELCO 6624)

A twin-belt pulley on PR engine or triple belt pulley on MX engine for driving a compressor, alternator or hydraulic system pump can be fitted to the crankshaft by the bodybuilder. A drawing of the pulley is available from DAF. When this pulley is fitted, the fan will in most cases be moved forward. This should be compensated for. A twin belt pulley is available to all FR engines and GR 220 engine ex-factory.

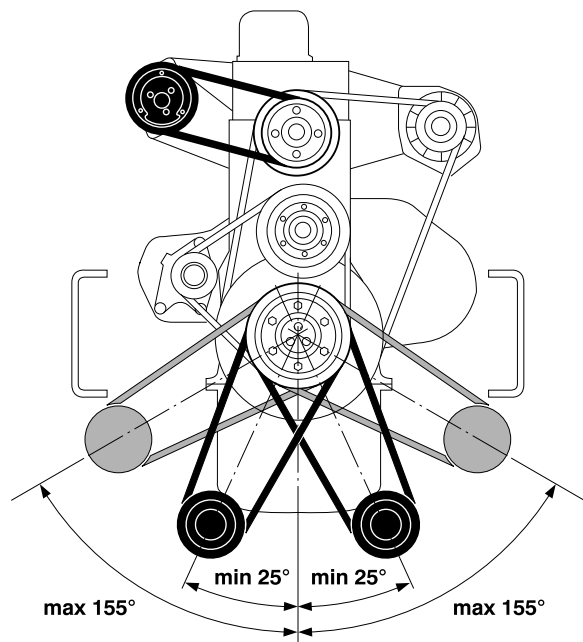

96120404-615

Positions of power take-offs

	LF45 - LF55 - CF65	CF75	CF85
Pulley diameter	310 mm	300 mm	265 mm
Number of grooves	2 x SPA / XPA	2 x DIN7753-AV13	3 x DIN7753-AV13

Before a crankshaft pulley is fitted, the mounting face on the vibration damper must be completely flat and clean. So any traces of paint should be removed. The belt pull must **not** run parallel to the motion of the pistons but must be in the area left and right of the engine indicated in the drawing below.

- Coolant pump pulley

On CF75-85 and XF vehicles without air conditioning system, one coolant pump pulley is available for the drive of an auxiliary user. For maximum power take-offs, see the overview.

- Preparation for generator

In particular for temperature-controlled transport, the LF55, CF65, CF85 and XF Series can be prepared ex-works for the use of a generator. In the case of the LF55 and CF65 (SELCO 0590-17kW, SELCO 0591-24kW), the vehicle has:

- an extra crankshaft pulley
- uprated engine mounts, air compressor outlet pipe and air dryer pipe to give clearance to a generator
- driven pulley, belt, tensioner and generator mounting brackets (loose supplied)
- modified anti roll bar with the 24 kW generator

In case of the CF85 and XF Series (SELCO 6723), the vehicle has:

- an extra crankshaft pulley,
- an adapted oil sump to make room for a generator and
- two shorter oil filters instead of the standard oil filter.

Within the room available, a drive ratio of 1:2 can be realised. This results in a maximum generator capacity of 24 kVA. Because of the wide variety of generators and cooling motors, DAF does not supply the complete equipment. The bodybuilder will therefore have to complete the equipment, taking account of the following guidelines:

- V-belt tension: 500 - 600 N for CF85 and XF Series, 600 - 700 N for CF75 Series (per belt)
- extra vibration dampers must be fitted, using the existing hole pattern on the engine bracket.

If this option is not ordered ex-works, the vibration damper mounting hub must be replaced.

	LF - CF65 Series	CF75	CF85 - XF Serie
Pulley diameter	280 mm	300 mm	265 mm

BODYBUILDERS' GUIDELINES

PTO and other energy consumers

	LF - CF65 Series	CF75	CF85 - XF Serie
Number of grooves		2 x SPA / XPA	3 x SPA / XPA
Recommended V-belt	Poly V-belt	OPTIBELT SPA - 13 or OPTIBELT XPA - 13	OPTIBELT SPA - 13 or OPTIBELT XPA - 13

- Preparation for hydraulic pump (SELCO 9543)

For the PR and MX engine, an engine bracket with a standard ISO pump connection is available for the fitting of a hydraulic pump. The bracket is provided with a pulley and a belt tensioner. The pulley is driven from a pulley on the crankshaft.

Technical data:

- Maximum power take-off: 50kW
- Reduction ratio: 1 : 1
- Belt tension first assembly: 1500N.
Belt tension to be checked after 30 min.
750N min. - 950N max.
- Pump connection according ISO 7653,
splines according ISO14 - 8x32x36
- Modified oil sump

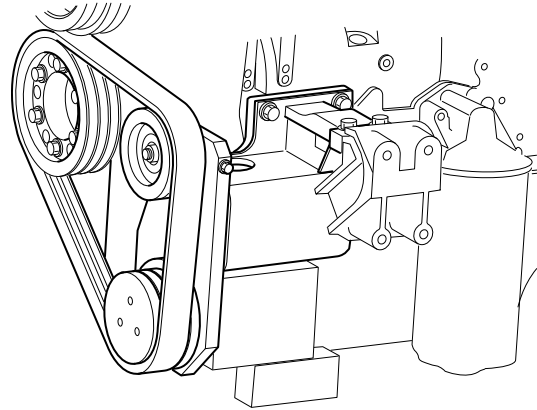

20090503-037

6

Engine PTO

The DAF engine PTO for the CF75 and CF85 series is a **clutch-independent PTO**. It was specially developed to drive superstructure equipment which requires medium-high outputs and is used for most of the driving hours and/or for a high number of operating hours when the vehicle is stationary.

The tables show the specifications and the locations for connecting this PTO. The engine PTO protrudes above the chassis members. So make sure that the PTO itself, the drive shafts and the hydraulic pump do not get in the way of parts of the chassis, the sub-frame or the superstructure.

Engine PTO specification					
Vehicle type	Speed factor	Direction of rotation	Maximum torque [Nm/min ⁻¹]	Service life [Hrs]	
LF and CF 65 Series	1.00	Anti- clockwise (1)	300 / 1500 (2)	1100	

(1) Viewed looking towards the rear of the engine

(2) The engine PTO does not contain a torque limiting fail safe device. If the PTO device fitted to the engine is likely to exceed 400 Nm in a failure condition, a fail safe device such as a shear pin should be incorporated into the PTO device.

Engine PTO specifications						
Vehicle type	Speed factor		Maximum torque [Nm/min ⁻¹]		Maximum output [kW/min ⁻¹]	
	Anti-clockwise ⁽¹⁾	Clockwise ⁽¹⁾				
CF75 series	-	0.932	990/1600	600/1600	150/2300	90/2300
	1.412	-	660/1600	400/1600	150/2300	90/2300
CF85 series	-	-	-	-	-	-
	1.20	-	800/1500	530/1500	150/1800	90/1800
Operating hours			1200	5500	1200	5500

(1) Viewed looking towards the rear of the engine

The speed data under 'Maximum torque' and 'Maximum output' refer to the engine speed. With released clutch a torque of about 13Nm will remain on the PTO output due to internal friction. Only applicable for the MX engine PTO.

Switch on conditions CF85 engine PTO:

The switch on/off conditions are controlled by the BBM

Max. power 85kW

Min. engine speed: 650 RPM

Max. engine speed: 1000 RPM

Vehicle speed under 50 km/h

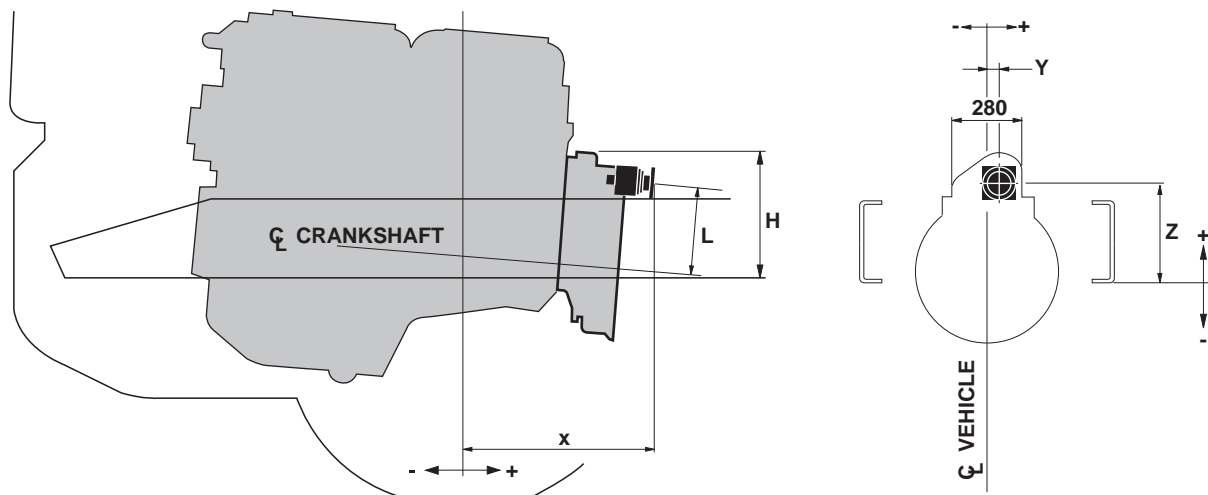

G001137

Locations for engine PTO connections						
Vehicle Series	Connection	Location				
		X	Y	Z	H	L
LF 45 Series	Direct pump connection	517	166	290	376	258
LF 55 Series	Direct pump connection	467		329		
LF 55 Series 19T / CF 65 Series	Direct pump connection	417		329	415	

BODYBUILDERS' GUIDELINES

PTO and other energy consumers

Locations for engine PTO connections						
Vehicle Series	Connection	Location				
		X	Y	Z	H	L
CF75 series	Flange	651	40	367	493	347
	Direct pump connection	593		372		
CF85 series	Flange	653	139	339	450	320
	Direct pump connection	612		343		

Engine PTO connections

The engine PTO is available with:

- DIN 120 flange, 8-hole, CF75/85 Series
- DIN 100 flange, 6-hole, CF75/85 Series
- ISO 7653 (direct) pump connection. LF - CF Series. It is a dry connection, there is no oil feed from the engine.

The maximum added mass inertia for this DAF engine PTO is 1.6 kgm².

Engine PTO control

Engine PTO control, including a safeguard against **engaging** the PTO while the engine is running, is available on request (CF75/85 only). Engine PTO on LF and CF65 Series is without control, so continuously running.

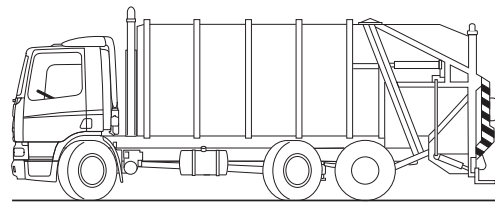

G001142

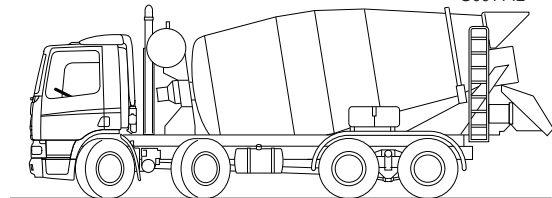

22032802-042

6



WARNING! The CF75 engine PTO must only be engaged when the engine is NOT running.



WARNING! The MX engine PTO should be ordered without clutch, when used for concrete mixer application, in order to prevent the PTO to be disengaged in case of low air pressure.

Flywheel PTO (NMV) only available with POV

Vehicle series	Gearbox	PTO types	Speed factor	Maximum torque [Nm]	Flange location			Note
					X	Y	Z	
CF75	16S1800 TO	NMV221	0.98	2000	913	38	304	(1) (2) (3) (4)
			1.55	1300				(1) (4) (5)
CF85	16S2200 TO 16S2500 TO		0.98	2000	1032	38	294	(1) (2) (4)
			1.55	1300				(1) (4) (5)

- (1) Flange, diameter 150 mm, 8-hole, 130 mm pitch
- (2) Service life of PTO at maximum torque: approx. 2000 operating hours
- (3) Maximum initial speed 2000 rpm
- (4) Maximum torque during continuous operation at engine speed of 1500 rpm
- (5) Service life of PTO at maximum torque: approx. 1500 operating hours

- An operating speed between 800 and 1000 RPM requires a minimum moment of inertia of 0,3 Kgm².
- In case the moment of inertia is unknown the operating engine speed should be over 1200 RPM.
- Permitted initial torque: $T_s = 1600$ Nm.
- Switch on revs. max. 2000 RPM for $i_{NMV} = 0,98$ and max. 1300 RPM when $i_{NMV} = 1,55$
- Max. moment of inertia at 1200 RPM at the output flange: 1 kgm² for $i_{NMV} = 1,55$ and 3 kgm² when $i_{NMV} = 0,98$

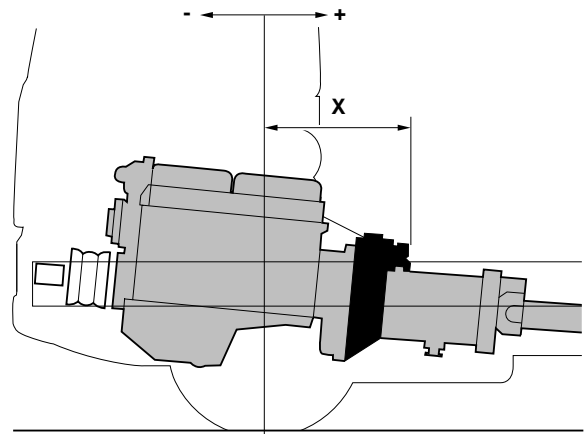

G000291

Location of flange of flywheel PTO.

Direction of rotation is anti-clockwise, viewed looking towards the rear of the gearbox. During prolonged heavy use of the flywheel PTO, the gearbox oil temperature must not rise above 110°C. To ensure that this condition is met, an air cooler or oil cooler may be necessary.

The flywheel PTO can be engaged and disengaged by using a multiple disc clutch (fitted as standard) while the engine is running.

When this PTO is disengaged, a residual torque of approx. 11 Nm (engine speed 1300 rpm and oil temperature 40°C) continues to act on the drive shaft. If necessary, a disc brake can be fitted on the drive shaft.

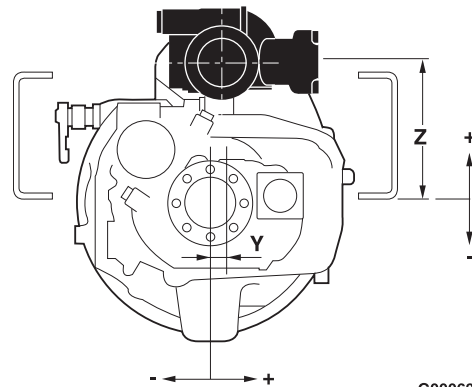

G000635

BODYBUILDERS' GUIDELINES

PTO and other energy consumers

6.5 CLUTCH-DEPENDENT PTO

Overview of PTO locations on ZF gearboxes¹⁾

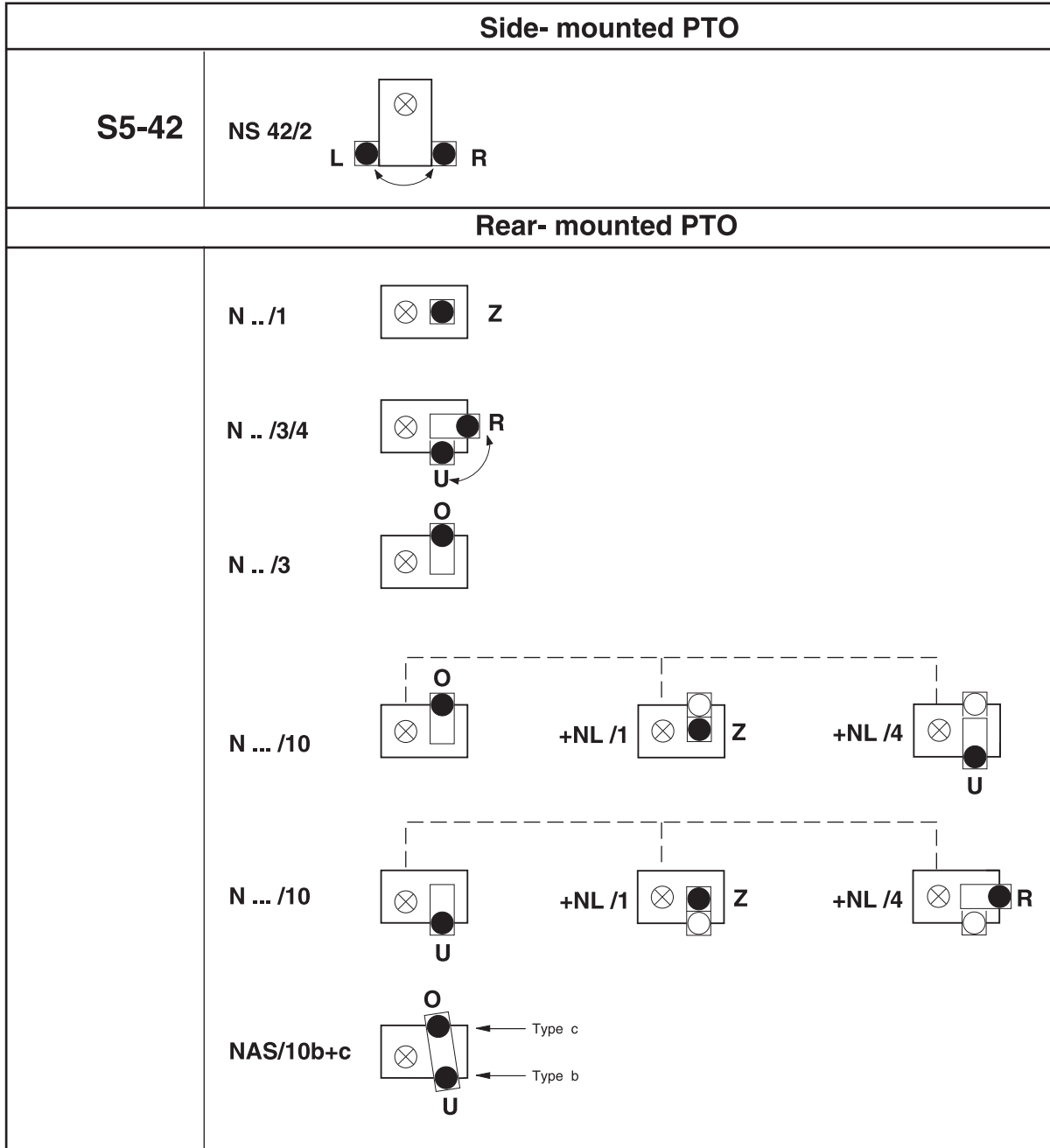

G000448

1) The designations of the PTO locations (indicated by large black dot) and the direction of rotation refer to the **mounting location of the PTO in the vehicle**, viewed looking towards the rear of the gearbox. These designations have to be used when ordering these PTO's: **Z**=Centre, **R**=Right, **U**=Under, **O**=above and **L**=Left in relation to the countershaft in the gearbox.

PTO flange position on gearbox

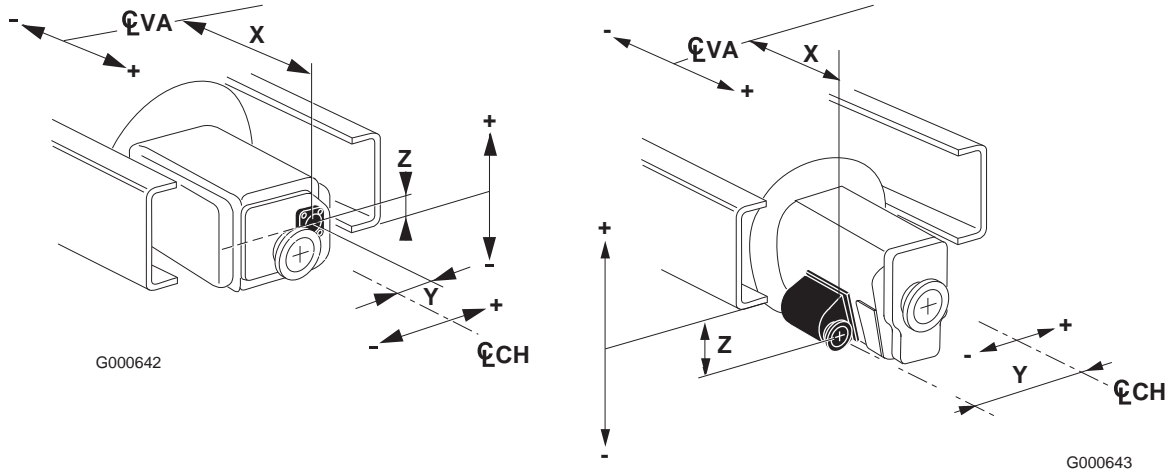

PTO flange locations (X, Y and Z dimensions) on gearboxes: VA = front axle centre line / CH = chassis centre line.

6.6 FIRST PTO

Manual gearbox - 6 speeds - Overdrive Gearbox 6S700 (6.02 - 0.79)								
Type	Selco	Loc.	Gear ratio	Speed factor	Max. torque [Nm]	RAPIDO reference		Notes
						PTO	Fitting Kit	
NL/1b	4844	Z	-	0.57	600	1609527	1701416	1, 7, 9
NL/1c	4846					1609528	1701343	2, 7, 9
NL/4b	6327	U	32 / 25	0.73	350	1609529	1701390	1, 8, 10
NL/4c	6328					1609530	1742233	2, 8, 10

1. PTO type b, with flange diameter 90 mm, 4-hole
2. PTO type c with direct pump connection, ISO 7653
7. Direction of rotation clockwise
8. Direction of rotation counter clockwise
9. Duration of operation, continuous
10. Duration of operation, < 30 min.

Manual gearbox - 6 speeds - Overdrive Gearbox 6S800 and 6S1000 (6.58 - 0.78)								
Type	Selco	Loc.	Gear ratio	Speed factor	Max. torque [Nm]	RAPIDO reference		Notes
						PTO	Fitting Kit	
NH/1b	4844	Z	-	0.53	800 (6S800) 1000 (6S1000)	1609500	1701416	1, 7, 9
NH/1c	4846					1609519	1701343	2, 7, 9
NH/4b	6327	U	32 / 25	0.67	350	1609520	1701390	1, 8, 10
NH/4c	6328					1609522	1742233	2, 8, 10

BODYBUILDERS' GUIDELINES

PTO and other energy consumers

Manual gearbox - 6 speeds - Overdrive Gearbox 6S800 and 6S1000 (6.58 - 0.78)								
Type	Selco	Loc.	Gear ratio	Speed factor	Max. torque [Nm]	RAPIDO reference		Notes
						PTO	Fitting Kit	
NL/10b or c		O	50 / 22	1.19	480			2, 3, 8, 9 only on POV
			55 / 17	1.70	320			
			58 / 17	2.03	270			

1. PTO type b, with flange diameter 90 mm, 4-hole
2. PTO type c with direct pump connection, ISO 7653
7. Direction of rotation clockwise
8. Direction of rotation counter clockwise
9. Duration of operation, continuous
10. Duration of operation, < 30 min.

Manual gearbox - 9 speeds - Direct drive Gearbox 9S1110 (12.73 - 1.00)							
Type	Selco	Loc.	Gear ratio	Speed factor	Maximum torque [Nm]	RAPIDO reference	Notes
						No ZF-Intarder	
NH/1b	4844	Z	-	0.72	800	1425376	1, 7, 9
NH/1c	4846					1425399	2, 7, 9
NH/4b	6327	U	32 / 25	0.92	430	1425404	1, 8, 10
	6558		27 / 30	0.65		1425409	
	4963	R	32 / 25	0.92		1425400	
	6329		27 / 30	0.65		1425402	
NH/4c	6328	U	32 / 25	0.92		1425405	2, 8, 10
	6575		27 / 30	0.65		1425410	
	4964	R	32 / 25	0.92		1425401	
	6342		27 / 30	0.65		1425403	
N109/10b	9642	O	44 / 36	0.88	630	1672130	4, 8, 9
	9641		48 / 32	1.08	530	1672129	
	9640		53 / 27	1.42	410	1672128	
N109/10c	9644	O	44 / 36	0.88	630	1672132	2, 8, 9
	9643		48 / 32	1.08	530	1672131	

1. PTO type b, with flange diameter 90 mm, 4-hole
2. PTO type c with direct pump connection, ISO 7653
4. PTO type b with flange diameter 100 mm, 6-hole
7. Direction of rotation clockwise
8. Direction of rotation counter clockwise
9. Duration of operation, continuous
10. Duration of operation, < 60 min.

BODYBUILDERS' GUIDELINES

PTO and other energy consumers

Manual gearbox - 9 speeds - Overdrive Gearbox 9S1110 and 9S1310 (9.48 - 0.75)							
Type	Selco	Loc.	Gear ratio	Speed factor	Maximum torque [Nm]	RAPIDO reference	Notes
						No ZF-Intarder	
NH/1b	4844	Z	-	0.97	800	1425376	1, 7, 9
NH/1c	4846					1425399	2, 7, 9
NH/4b	6327	U	32 / 25	1.24	430	1425404	1, 8, 10
	6558		27 / 30	0.87		1425409	
	4963	R	32 / 25	1.24		1425400	
	6329		27 / 30	0.87		1425402	
NH/4c	6328	U	32 / 25	1.24		1425405	2, 8, 10
	6575		27 / 30	0.87		1425410	
	4964	R	32 / 25	1.24		1425401	
	6342		27 / 30	0.87		1425403	
N109/10b	9642	O	44 / 36	1.19	630	1672130	4, 8, 9
	9641		48 / 32	1.45	530	1672129	
	9640		53 / 27	1.90	410	1672128	
N109/10c	9644	O	44 / 36	1.19	630	1672132	2, 8, 9
	9643		48 / 32	1.45	530	1672131	

1. PTO type b, with flange diameter 90 mm, 4-hole
2. PTO type c, with direct pump connection, ISO 7653
4. PTO type b, with flange, diameter 100 mm, 6-hole
7. Direction of rotation clockwise
8. Direction of rotation counter clockwise
9. Duration of operation, continuous
10. Duration of operation, < 60 min.

Gearbox Allison 3000, 3200 (3.49 - 0.75 and 3.49 - 0.65) and 3500 (4.59 - 0.75 and 4.59 - 0.65)							
Type	Selco	Loc.	Gear ratio	Speed factor	Maximum torque [Nm]	RAPIDO reference	Notes
277XGFJP-D5XY	8501	R	31 / 41	1.03	405 / 285	1339954	2, 8
277XSFJP-D5XX	8500		39 / 33	1.61	335 / 235	1339952	4, 8
859XGFJP-D5AC	2476		24 / 43	0.76	780 / 550	1604963	4, 8
Permitted maximum torque for intermittent / continuous use (any duty cycle longer than 5 minutes is classed as continuous)							
Permitted maximum torque for fir brigade application is 80% of the intermittent rating							

2. Direct pump connection, ISO 7653
4. Flange, diameter 100 mm, 6-hole
8. Direction of rotation counter clockwise

BODYBUILDERS' GUIDELINES

PTO and other energy consumers

Manual gearbox - 8 speeds - Direct drive Gearbox 8S1620 (13.80 - 1.00)								
Type	Selco	Loc.	Gear ratio	Speed factor	Max. torque [Nm]	RAPIDO reference		Notes
						No ZF-Intarder	With ZF-Intarder	
NH/1b	4844	Z	-	0.91	1000	1801647	1801611	1, 7, 9
NH/1c	4846					1801645	1801609	2, 7, 9
NH/4b	6327	U	32 / 25	1.17	430	1801666	1801625	1, 8, 10
	6558		27 / 30	0.82		1801668	1801627	
	4963	R	32 / 25	1.17		1801674	1801633	
	6329		27 / 30	0.82		1801676	1801635	
NH/4c	6328	U	32 / 25	1.17		1801661	1801621	2, 8, 10
	6575		27 / 30	0.82		1801663	1801623	
	4964	R	32 / 25	1.17		1801670	1801629	
	6342		27 / 30	0.82		1801672	1801631	
N221/10b	4851	U	37 / 30	1.13	870	1801659	1801617	4, 8, 9
	4848		40 / 27	1.35	730	1801657	1801617	
	4849		44 / 23	1.75	560	1801355	1801615	
	4850		46 / 21	2.00	470	1801653	1801613	
N221/10c	6285	O	37 / 30	1.13	870	1801684	1801643	2, 8, 9
	6262		40 / 27	1.35	730	1801682	1801641	
	6217		44 / 23	1.75	560	1801680	1801639	
	8504		46 / 21	2.00	470	1801678	1801637	

1. PTO type b with flange diameter 90 mm, 4-hole
2. PTO type c with direct pump connection, ISO 7653
4. PTO type b with flange diameter 100 mm, 6-hole
7. Direction of rotation clockwise
8. Direction of rotation counter clockwise
9. Duration of operation, continuous
10. Duration of operation, < 60 min.

Manual gearbox - 8 speeds - Overdrive Gearbox 8S1820, 8S2220 (11.54 - 0.84)								
Type	Selco	Loc.	Gear ratio	Speed factor	Max. torque [Nm]	RAPIDO reference		Notes
						No ZF-Intarder	With ZF-Intarder	
NH/1b	4844	Z	-	1.09	1000	1801647	1801611	1, 7, 9
NH/1c	4846					1801645	1801609	2, 7, 9

BODYBUILDERS' GUIDELINES

PTO and other energy consumers

Manual gearbox - 8 speeds - Overdrive Gearbox 8S1820, 8S2220 (11.54 - 0.84)								
Type	Selco	Loc.	Gear ratio	Speed factor	Max. torque [Nm]	RAPIDO reference		Notes
						No ZF-Intarder	With ZF-Intarder	
NH/4b	6327	U	32 / 25	1.40	430	1801666	1801625	1, 8, 10
	6558		27 / 30	0.98		1801668	1801627	
	4963	R	32 / 25	1.40		1801674	1801633	
	6329		27 / 30	0.98		1801676	1801635	
NH/4c	6328	U	32 / 25	1.40		1801661	1801621	2, 8, 10
	6575		27 / 30	0.98		1801663	1801623	
	4964	R	32 / 25	1.40		1801670	1801629	
	6342		27 / 30	0.98		1801672	1801631	
N221/10b	4851	U	37 / 30	1.35	870	1801659	1801619	4, 8, 9
	4848		40 / 27	1.62	730	1801657	1801617	
	4849		44 / 23	2.09	560	1801655	1801615	
	4850		46 / 21	2.40	470	1801653	1801613	
N221/10c	6285	O	37 / 30	1.35	870	1801684	1801643	2, 8, 9
	6262		40 / 27	1.62	730	1801682	1801641	
	6217		44 / 23	2.09	560	1801680	1801639	
	8504		46 / 21	2.40	470	1801678	1801637	

1. PTO type b with flange diameter 90 mm, 4-hole
2. PTO type c with direct pump connection, ISO 7653
4. PTO type b with flange diameter 100 mm, 6-hole
7. Direction of rotation clockwise
8. Direction of rotation counter clockwise
9. Duration of operation, continuous
10. Duration of operation, < 60 min.

Manual gearbox - 16 speeds - Direct drive Gearbox 16S1620, 16S1920, 16S2020, 16S2220 and 16S2320 (16.41 - 1.00)								
Type	Selco	Loc.	Gear ratio	Speed factor	Max. torque [Nm]	RAPIDO reference		Notes
						No ZF-Intarder	With ZF-Intarder	
NH/1b	4844	Z	-	0.77 / 0.91	1000	1801647	1801611	1, 7, 9
NH/1c	4846					1801645	1801609	2, 7, 9
NH/4b	6327	U	32 / 25	0.98 / 1.17	430	1801666	1801625	1, 8, 10
	6558		27 / 30	0.69 / 0.82		1801668	1801627	
	4963	R	32 / 25	0.98 / 1.17		1801674	1801633	
	6329		27 / 30	0.69 / 0.82		1801676	1801635	
NH/4c	6328	U	32 / 25	0.98 / 1.17		1801661	1801621	2, 8, 10
	6575		27 / 30	0.69 / 0.82		1801663	1801623	
	4964	R	32 / 25	0.98 / 1.17		1801670	1801629	
	6342		27 / 30	0.69 / 0.82		1801672	1801631	

BODYBUILDERS' GUIDELINES

PTO and other energy consumers

Manual gearbox - 16 speeds - Direct drive Gearbox 16S1620, 16S1920, 16S2020, 16S2220 and 16S2320 (16.41 - 1.00)								
Type	Selco	Loc.	Gear ratio	Speed factor	Max. torque [Nm]	RAPIDO reference		Notes
						No ZF-Intarder	With ZF-Intarder	
N221/10b	4851	U	37 / 30	0.95 / 1.13	870	1801659	1801619	4, 8, 9
	4848		40 / 27	1.14 / 1.35	730	1801657	1801617	
	4849		44 / 23	1.47 / 1.75	560	1801655	1801615	
	4850		46 / 21	1.68 / 2.00	470	1801653	1801613	
N221/10c	6285	O	37 / 30	0.95 / 1.13	870	1801684	1801643	2, 8, 9
	6262		40 / 27	1.14 / 1.35	730	1801682	1801641	
	6217		44 / 23	1.47 / 1.75	560	1801680	1801639	
	8504		46 / 21	1.68 / 2.00	470	1801678	1801637	
	6193	U	37 / 30	0.95 / 1.13	870	1801651		
	6119		40 / 27	1.14 / 1.35	730	1801650		
	9213		44 / 23	1.47 / 1.75	560	1801649		
	2630		46 / 21	1.68 / 2.00	470	1801648		

6

1. PTO type b with flange diameter 90 mm, 4-hole
2. PTO type c with direct pump connection, ISO 7653
4. PTO type b with flange diameter 100 mm, 6-hole
7. Direction of rotation clockwise
8. Direction of rotation counter clockwise
9. Duration of operation, continuous
10. Duration of operation, < 60 min.

Manual gearbox - 16 speeds - Overdrive Gearbox 16S1820, 16S2220, 16S2520 and 16S2720 (13.80 - 0.84)								
Type	Selco	Loc.	Gear ratio	Speed factor	Max. torque [Nm]	RAPIDO reference		Notes
						No ZF-Intarder	With ZF-Intarder	
NH/1b	4844	Z	-	0.91 / 1.09	1000	1801647	1801611	1, 7, 9
NH/1c	4846					1801645	1801609	2, 7, 9
NH/4b	6327	U	32 / 25	1.17 / 1.40	430	1801666	1801625	1, 8, 10
	6558		27 / 30	0.82 / 0.98		1801668	1801628	
	4963	R	32 / 25	1.17 / 1.40		1801674	1801633	
	6329		27 / 30	0.82 / 0.98		1801676	1801635	
NH/4c	6328	U	32 / 25	1.17 / 1.40		1801661	1801621	2, 8, 10
	6575		27 / 30	0.82 / 0.98		1801663	1801623	
	4964	R	32 / 25	1.17 / 1.40		1801670	1801629	
	6342		27 / 30	0.82 / 0.98		1801672	1801631	
N221/10b	4851	U	37 / 30	1.13 / 1.35	870	1801659	1801619	4, 8, 9
	4848		40 / 27	1.35 / 1.62	730	1801657	1801617	
	4849		44 / 23	1.75 / 2.09	560	1801655	1801615	
	4850		46 / 21	2.00 / 2.40	470	1801653	1801613	

BODYBUILDERS' GUIDELINES

PTO and other energy consumers

Manual gearbox - 16 speeds - Overdrive Gearbox 16S1820, 16S2220, 16S2520 and 16S2720 (13.80 - 0.84)								
Type	Selco	Loc.	Gear ratio	Speed factor	Max. torque [Nm]	RAPIDO reference		Notes
						No ZF-Intarder	With ZF-Intarder	
N221/10c	6285	O	37 / 30	1.13 / 1.35	870	1801684	1801643	2, 8, 9
	6262		40 / 27	1.35 / 1.62	730	1801682	1801641	
	6217		44 / 23	1.75 / 2.09	560	1801680	1801639	
	8504		46 / 21	2.00 / 2.40	470	1801678	18016370	
	6193	U	37 / 30	1.13 / 1.35	870	1801651		
	6119		40 / 27	1.35 / 1.62	730	1801650		
	9213		44 / 23	1.75 / 2.09	560	1801649		
	2630		46 / 21	2.00 / 2.40	470	1801648		

1. PTO type b with flange diameter 90 mm, 4-hole
2. PTO type c with direct pump connection, ISO 7653
4. PTO type b with flange diameter 100 mm, 6-hole
7. Direction of rotation clockwise
8. Direction of rotation counter clockwise
9. Duration of operation, continuous
10. Duration of operation, < 60 min.

6

AS-Tronic - 6 speeds - Overdrive Gearbox 6AS700 (6.02 - 0.79)								
Type	Selco	Loc.	Gear ratio	Speed factor	Max. torque [Nm]	RAPIDO reference		Notes
						PTO	Fitting Kit	
NL/1b	4844	Z	-	0.57	600	1609527	1701416	1, 7, 9
NL/1c	4846					1609528	1701343	2, 7, 9
NL/4b	6327	U	32 / 25	0.73	350	1609529	1701390	1, 8, 10
NL/4c	6328					1609530	1742233	2, 7, 10

1. PTO type b, with flange diameter 90 mm, 4-hole
2. PTO type c with direct pump connection, ISO 7653
7. Direction of rotation clockwise
8. Direction of rotation counter clockwise
9. Duration of operation, continuous
10. Duration of operation, < 30 min.

AS-Tronic - 6 speeds - Overdrive Gearbox 6AS800 and 6AS1000 (6.58 - 0.78)								
Type	Selco	Loc.	Gear ratio	Speed factor	Max. torque [Nm]	RAPIDO reference		Notes
						PTO	Fitting Kit	
NH/1b	4844	Z	-	0.53	800 (6AS800) 1000 (6AS1000)	1609500	1701416	1, 7, 9
NH/1c	4846					1609519	1701343	2, 7, 9
NH/4b	6327	U	32 / 25	0.67	350	1609520	1701390	1, 8, 10
NH/4c	6328					1609522	1742233	2, 8, 10

BODYBUILDERS' GUIDELINES

PTO and other energy consumers

1. PTO type b, with flange diameter 90 mm, 4-hole
2. PTO type c with direct pump connection, ISO 7653
7. Direction of rotation clockwise
8. Direction of rotation counter clockwise
9. Duration of operation, continuous
10. Duration of operation, < 60 min.

AS-Tronic - 12 speeds - Direct drive Gearbox 12AS1220 and 12AS1420 (12.83 - 1.00)							
Type	Selco	Loc.	Gear ratio	Speed factor	Max. torque [Nm]	RAPIDO reference	Notes
NH/1b	4844	Z	-	0.80	800	1671921	1, 7, 9
NH/1c	4846					1671922	2, 7, 9
NH/4b	6327	U	32 / 25	1.02	430	1780518	1, 8, 10
	4963	R				1780516	
NH/4c	6328	U				1780519	2, 8, 10
	4964	R				1780517	
NH/4b	6558	U	27 / 30	0.72		1671925	1, 8,10
	6329	R				1671923	
NH/4c	6575	U				1671926	2, 8, 10
	6342	R				1671924	
NM AS/10b	4851	U	37 / 30	0.99	590	1671980	4, 8, 9
	4848		40 / 27	1.18	510	1671982	
	4849		44 / 23	1.53	420	1671984	
NM AS/10c	6285	O	37 / 30	0.99	590	1671978	2, 8, 9
	6262		40 / 27	1.18	510	1671976	
	6217		44 / 23	1.53	420	1671974	

1. PTO type b, with flange diameter 90 mm, 4-holes
2. PTO type c, with direct pump connection, ISO 7653
4. PTO type b, with flange diameter 100mm, 6-holes
7. Direction of rotation clockwise
8. Direction of rotation counter clockwise
9. Duration of operation, continuous
10. Duration of operation, < 60 min.

Note: with two active PTO's, NMAS/10b+c, the maximum allowed torque on the lay shaft is reduced to 800Nm. The pump connection is always in the upper and flange connection is in the lower position.

AS-Tronic - 12 speeds - Overdrive Gearbox Gearbox 12AS1420 and 12AS1620 (10.37 - 0.81)							
Type	Selco	Loc.	Gear ratio	Speed factor	Max. torque [Nm]	RAPIDO reference	Notes
NH/1b	4844	Z	-	0.99	800	1671921	1, 7, 9
NH/1c	4846					1671922	2, 7, 9

BODYBUILDERS' GUIDELINES

PTO and other energy consumers

AS-Tronic - 12 speeds - Overdrive Gearbox Gearbox 12AS1420 and 12AS1620 (10.37 - 0.81)							
Type	Selco	Loc.	Gear ratio	Speed factor	Max. torque [Nm]	RAPIDO reference	Notes
NH/4b	6327	U	32 / 25	1.27	430	1780518	1, 8, 10
	4963	R				1780516	
NH/4c	6328	U				1780519	2, 8, 10
	4964	R				1781517	
NH/4b	6558	U	27 / 30	0.89	430	1671925	1, 8, 10
	6329	R				1671923	
NH/4c	6575	U				1671926	2, 8, 10
	6342	R				1671924	
NM AS/10b	4851	U	37 / 30	1.22	590	1671980	4, 8, 9
	4848		40 / 27	1.47	510	1671982	
	4849		44 / 23	1.89	420	1671984	
NM AS/10c	6285	O	37 / 30	1.22	590	1671978	2, 8, 9
	6262		40 / 27	1.47	510	1671976	
	6217		44 / 23	1.89	420	1671974	

1. PTO type b with flange diameter 90 mm, 4-hole
2. PTO type c with direct pump connection, ISO 7653
4. PTO type b with flange diameter 100 mm, 6-hole
7. Direction of rotation clockwise
8. Direction of rotation counter clockwise
9. Duration of operation, continuous
10. Duration of operation, < 60 min.

Note: with two active PTO's, NMAS/10b+c, the maximum allowed torque on the lay shaft is reduced to 800Nm. The pump connection is always in the upper and flange connection is in the lower position.

AS-Tronic - 12 speeds - Overdrive Gearbox 12AS1930, 12AS2130, 12AS2330 and 12AS2530 (12.33 - 0.78)								
Type	Selco	Loc.	Gear ratio	Speed factor	Max. torque [Nm]	RAPIDO reference		Notes
						No ZF-Intarder	With ZF-Intarder	
NH/1b	4844	Z	-	1.35	1000	1448298	1809375	1, 7, 9
NH/1c	4846					1448299	1809376	2, 7, 9
NH/4b	6558	U	27 / 30	1.22	430	1448306	1809374	1, 8, 10
	6329	R				1448302	1809373	
NH/4c	6575	U				1448307	1809368	2, 8, 10
	6342	R				1448303	1809367	
NAS/10b	8994	U	35 / 32	1.48	710	1448219	1809436	4, 8, 9
	8996		32 / 25	1.73	580	1448218	1809435	
	8995		35 / 22	2.15	490	1448217	1809433	

BODYBUILDERS' GUIDELINES

PTO and other energy consumers

AS-Tronic - 12 speeds - Overdrive Gearbox 12AS1930, 12AS2130, 12AS2330 and 12AS2530 (12.33 - 0.78)								
Type	Selco	Loc.	Gear ratio	Speed factor	Max. torque [Nm]	RAPIDO reference		Notes
						No ZF-Intarder	With ZF-Intarder	
NAS/10c	8989	O	29 / 38	1.03	730	1613796	1809437	2, 8, 9
	8987		32 / 35	1.24	720	1613797	1809438	
	2713	U	29 / 38	1.03	730	1685788	1809453	
	2716		32 / 35	1.24	720	1685789	1809454	
NAS/10b + NAS/10c	8977	U	29 / 28	1.40	600	1613800	1809442	2, 4, 8, 9
		O	29 / 38	1.03	730			
NAS/10b + NAS/10c	9878	U	32 / 25	1.73	580	1613799	1809440	2, 4, 8, 9
		O	32 / 35	1.24	720			
NAS/10b + NAS/10c	8979	U	35 / 22	2.15	490	1613798	1809439	2, 4, 8, 9
		O	35 / 32	1.48	710			

1. PTO type b with flange diameter 90 mm, 4-hole
2. PTO type c with direct pump connection, ISO 7653
4. PTO type b with flange diameter 100 mm, 6-hole
7. Direction of rotation clockwise
8. Direction of rotation counter clockwise
9. Duration of operation, continuous
10. Duration of operation, < 60 min.

Note: with two active PTO's, NAS/10b+c, the maximum allowed torque on the lay shaft is reduced to 1000Nm. The pump connection is always in the upper and flange connection is in the lower position.

AS-Tronic - 12 speeds - Direct drive Gearbox 12AS1630, 12AS1930, 12AS2130, 12AS2330 and 12AS2540 (15.86 - 1.0)								
Type	Selco	Loc.	Gear ratio	Speed factor	Max. torque [Nm]	RAPIDO reference		Notes
						No ZF-Intarder	With ZF-Intarder	
NH/1b	4844	Z	-	0.82	1000	1448298	1809375	1, 7, 9
NH/1c	4846					1448299	1809376	2, 7, 9
NH/4b	6327	U	32 / 25	1.05	430	1448304	1809372	1, 8, 10
	6558		27 / 30	0.74		1448306	1809374	
	4963	R	32 / 25	1.05		1448300	1809369	
	6329		27 / 30	0.74		1448302	1809373	
NH/4c	6328	U	32 / 25	1.05	430	1448305	1809366	2, 8, 10
	6575		27 / 30	0.74		1448307	1809368	
	4964	R	32 / 25	1.05		1448301	1809365	
	6342		27 / 30	0.74		1448303	1809367	
N AS/10b	6751	U	37 / 20	1.51	430	1448210	1809426	4, 8, 9
	6750		40 / 17	1.93	400	1448209	1809425	
	6679		41 / 16	2.10	360	1448208	1809424	

BODYBUILDERS' GUIDELINES

PTO and other energy consumers

AS-Tronic - 12 speeds - Direct drive Gearbox 12AS1630, 12AS1930, 12AS2130, 12AS2330 and 12AS2540 (15.86 - 1.0)								
Type	Selco	Loc.	Gear ratio	Speed factor	Max. torque [Nm]	RAPIDO reference		Notes
						No ZF-Intarder	With ZF-Intarder	
N AS/10c	6922	O	37 / 30	1.01	690	1613792	1809429	2, 8, 9
	6915		40 / 27	1.21	670	1613791	1809428	
	6803		41 / 26	1.29	630	1613790	1809427	
	8243	U	37 / 30	1.01	690	1685784	1809452	
	2633		40 / 27	1.21	670	1685783	1809451	
	2705		41 / 26	1.29	630	1685782	1809450	
NAS/10b+ NAS/10c	6965	U	37 / 20	1.51	430	1613795	1809432	2, 4, 8, 9
		O	37 / 30	1.01	690			
NAS/10b+ NAS/10c	6964	U	40 / 17	1.93	400	1613794	1809431	2, 4, 8, 9
		O	40 / 27	1.21	670			
NAS/10b+ NAS/10c	6960	U	41 / 16	2.10	360	1613793	1809430	2, 4, 8, 9
		O	41 / 26	1.29	630			

1. PTO type b with flange diameter 90 mm, 4-hole
2. PTO type c with direct pump connection, ISO 7653
4. PTO type b with flange diameter 100mm, 6-hole
7. Direction of rotation clockwise
8. Direction of rotation counter clockwise
9. Duration of operation, continuous
10. Duration of operation, < 60 min.

Note: with two active PTO's, NAS/10b+c, the maximum allowed torque on the lay shaft is reduced to 1000Nm. The pump connection is always in the upper and flange connection is in the lower position.

AS-Tronic - 16 speeds - Overdrive Gearbox 16AS2630 (14.12 - 0.83)								
Type	Selco	Loc.	Gear ratio	Speed factor	Max. torque [Nm]	RAPIDO reference		Notes
						No ZF-Intarder	With ZF-Intarder	
NH/1b	4844	Z	-	1.11	1000	1448298	1809375	1, 7, 9
NH/1c	4846					1448299	1809376	2, 7, 9
NH/4b	6558	U	27 / 30	1.00	430	1448306	1809374	1, 8, 10
	6329	R				1448302	1809373	
NH/4c	6575	U				1448307	1809368	2, 8, 10
	6342	R				1448303	1809367	
NAS/10b	8994	U	35 / 32	1.21	710	1448219	1809436	4, 8, 9
	8996		32 / 25	1.42	580	1448218	1809435	
	8995		35 / 22	1.77	490	1448217	1809433	
NAS/10c	8989	O	29 / 38	0.85	730	1613796	1809437	2, 8, 9
	8987		32 / 35	1.02	720	1613797	1809438	

BODYBUILDERS' GUIDELINES

PTO and other energy consumers

AS-Tronic - 16 speeds - Overdrive Gearbox 16AS2630 (14.12 - 0.83)								
Type	Selco	Loc.	Gear ratio	Speed factor	Max. torque [Nm]	RAPIDO reference		Notes
						No ZF-Intarder	With ZF-Intarder	
NAS/10b + NAS/10c	8977	U	29 / 28	1.15	600	1613800	1809442	2, 4, 8, 9
		O	29 / 38	0.85	730			
NAS/10b + NAS/10c	8978	U	32 / 25	1.42	580	1613799	1809440	2, 4, 8, 9
		O	32 / 35	1.02	720			
NAS/10b + NAS/10c	8979	U	35 / 22	1.77	490	1613798	1809439	2, 4, 8, 9
		O	35 / 32	1.21	710			

1. PTO type b with flange diameter 90 mm, 4-hole
2. PTO type c with direct pump connection, ISO 7653
4. PTO type b with flange diameter 100mm, 6-hole
7. Direction of rotation clockwise
8. Direction of rotation counter clockwise
9. Duration of operation, continuous
10. Duration of operation, < 60 min.

6

Note: with two active PTO's, NAS/10b+c, the maximum allowed torque on the lay shaft is reduced to 1000Nm. The pump connection is always in the upper and flange connection is in the lower position.

6.7 SECOND PTO

Second PTO for CF75 - CF85 and XF Series

NM AS/10 in combination with				12AS1220 12AS1420 12.83 - 1.00	12AS1220 12AS1420 12AS1620 10.37 - 0.81		
Type	Selco	Loc.	Gear ratio	Speed factor	Speed factor	PTO reference	Notes
NL/1b	4853	Z	-	0.80	0.99	1399245	3, 7, 9
NL/1c	4855					1399246	2, 7, 9
NL/4b	1817	O	27 / 30	0.72	0.89	1801537	3, 6, 8, 10
	1825		32 / 25	1.02	1.27	1801539	
	6174	U	27 / 30	0.72	0.89	1399304	
	4996		32 / 25	1.02	1.27	1399250	
NL/4c	1872	O	27 / 30	0.72	0.89	1801541	2, 6, 8, 10
	1873		32 / 25	1.02	1.27	1801545	
	6538	U	27 / 30	0.72	0.89	1399305	
	4997		32 / 25	1.02	1.27	1399251	

2. Direct pump connection, ISO 7653
3. Flange diameter 75mm, 6-hole
6. Mounting position O in combination with NM AS/10
U, mounting position U in combination with NM AS/
10 O
7. Direction of rotation clockwise
8. Direction of rotation counter clockwise
9. Duration of operation, continuous at max. torque
600Nm
10. Duration of operation, < 60 min. at max. torque
430Nm

Note: with two active PTO's the maximum allowed torque on the lay shaft is reduced to 800Nm, for the NMAS/10b+c and to 1000Nm for the NAS/10b+c

N221/10 in combination with				8S1620	8S1820 8S2220	16S1820 16S2020 16S2220 16S2520 16S2720	16S1620 16S1920 16S2020 16S2220 16S2320		
				13.80-1.0	11.54-0.84	13.80-0.84	16.41-1.0		
Type	Selco	Loc.	Gear ratio	Speed factor	Speed factor	Speed factor	Speed factor	PTO refer- ence	Notes
NL/1b	4853	Z	-	0.91	1.09	0.91 / 1.09	0.77 / 0.91	1399245	3, 7, 9
NL/1c	4855							1399246	2, 7, 9
NL/4b	6174	U	27 / 30	0.82	0.98	0.82 / 0.98	0.69 / 0.82	1399304	3, 6, 8, 10
	4996		32 / 25	1.17	1.40	1.17 / 1.40	0.98 / 1.17	1399250	
	6155	R	27 / 30	0.82	0.98	0.82 / 0.98	0.69 / 0.82	1399252	
	4965		32 / 25	1.17	1.40	1.17 / 1.40	0.98 / 1.17	1399247	
NL/4c	6538	U	27 / 30	0.82	0.98	0.82 / 0.98	0.69 / 0.82	1399305	2, 6, 8, 10
	4997		32 / 25	1.17	1.40	1.17 / 1.40	0.98 / 1.17	1399251	
	6173	R	27 / 30	0.82	0.98	0.82 / 0.98	0.69 / 0.82	1399302	
	4966		32 / 25	1.17	1.40	1.17 / 1.40	0.98 / 1.17	1399249	

6.8 TRANSFER BOX

Transfer case PTO

Re-location of the tachograph speed sensor from outputshaft gearbox to outputshaft transfercase (to rear-axle) is required.

Also new tachograph calibration is mandatory.

In case the transfercase does not have a 1:1 ratio between input shaft speed and output shaft speed (to rear axle) also new vehicle system software is required.

For the use of PTO's on transfer cases or for the use of the transfer case as a PTO, you should **always** contact DAF.

6.9 PTO OPERATION

The cable harnesses of all DAF series are as standard prepared for PTO control wiring from the rear of the dashboard central console to the BBM (for LF Series to VIC) unit and from the BBM (for LF Series from VIC unit to the bulkhead lead-through. In the CF and XF series, the wiring from the bulkhead lead-through to the relevant electrical connection in the chassis upto the gearbox is also provided. On LF vehicles, the PTO switch can be mounted in the dashboard and directly connected, but on CF and XF vehicles a switch and a cable harness is required. All switchable PTO's are controlled by an electrical switch on the dashboard, interlock conditions in the BBM (for LF Series in the VIC) an electric/pneumatic valve in the chassis and a status return switch. On vehicles ex-works supplied with PTO preparation (except for LF and CF65 Series vehicles equipped with Allison Automatic Gearboxes), the PTO switch and wiring to BBM (for LF Series to VIC) is fitted in the reserved place in the dashboard and also additional wiring from gearbox to E/Pvalve and the E/Pvalve itself are fitted.

6

For PTO control and protection, see chapter 9.11: "LF series PTO control / protection", 10.18: "CF series PTO control / protection", or 11.16: "XF series PTO controls / protection". Dashboard switches are available as accessories from DAF Parts; for the part numbers concerned see chapter 13: "Part numbers".

The vehicles of the **LF and CF65 Series** are prepared for PTO1 operation **only**, which is controlled and checked via the VIC. The CF65 Serie does have the cab preparation for two PTO's via VIC, the chassis wiring loom however is only suitable for one PTO control and status return.

For the **CF75/85 and XF Series**, the operating system for at most 2 PTO's can be supplied ex-works, although three PTO switch positions are provided in the dashboard. They can be used, for instance:

- for a first PTO on the gearbox,
- for a second PTO on the gearbox and
- for an engine-dependent PTO.

For positions reserved for PTO switches, see chapters 9.1: "LF series cab switch and connector locations", 10.1: "CF series cab switch and connector locations", 11.1: "XF series cab switch and connector locations".

The range of available PTO's is linked to a specific PTO switch as is shown in the following table:

PTO1 switch	PTO2 switch
Engine PTO	--
Engine PTO	N../1 or N../4
Engine PTO	N../10
Engine PTO	Chelsea
--	N../10
N../1 or N../4	N../10
N../1 or N../4	--
NAS/10 b or c	--
--	Chelsea
NAS/10 b	NAS/10c

For N../10 PTO's, always the version with clutch protection must be specified.

If an N221/10 PTO is fitted at a later stage, the electrical system should be adapted (relay G259 should be added).

The N../10 PTO and a Chelsea PTO are always operated by the PTO2 switch and VIC interlocks. For further information, consult DAF.

6.10 COMPRESSED AIR SYSTEM

Modifications to the vehicle brake system must NOT be made without the prior written permission of DAF.



WARNING! Mechanical damage to the components of the brake system, in whatever form, should always be avoided.

All vehicle series

Air consumers can be connected an unused port of the air distribution unit (A) of circuit 4 of the CF75/85 and XF Series (this unit is connected to port 24 of the APU valve and is located on the left-hand side of the cab, behind the entrance steps). The air distribution unit on the FT CF and XF Series, WB 3.60m and 3.80m only, is located at the left side of the chassis in between the flanges of the K-crossmember.

The LF and CF65 Series, except when equipped with air suspension or ASR, have an air pipe in the right hand side member sealed with a red bung, which should be replaced with a standard DAF fitting to suit the feed required. Air could also be taken from the auxiliary circuit, port 28, by removing the blanking plug and fitting an M12 adapter.

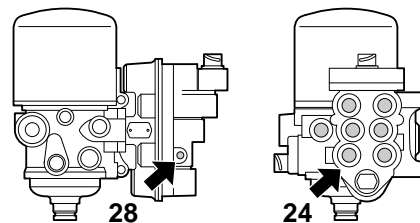

20070604-019

Port for connection of air consumers to APU valve

BODYBUILDERS' GUIDELINES

PTO and other energy consumers

Various tee couplings and other (L-V) Voss232 NG12 couplings are available for CF75/85 and XF Series through DAF Parts. Only Voss 232 connectors should be used and only port 2 or 3 can be used. For the part numbers, see the DAF Parts product range documentation and section 13.11: "Adapters air system".



WARNING! The minimum system pressure is $8.8^{\pm 0.2}$ bar, the maximum system pressure is $10.4^{\pm 0.2}$ bar for LF, CF and XF Series.

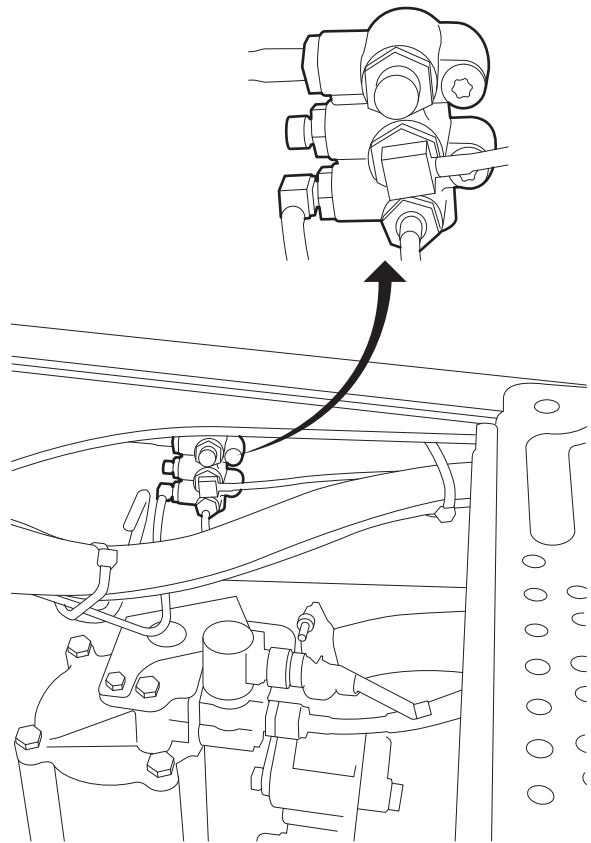

Circuit 4 air distribution unit on tractors 4x2
(CF75/85 and XF Series)

General remarks

Before the APU valve and in system circuit 4, there is no supply of compressed air therefore it is essential that external air consumers should only be supplied with air when the vehicle engine is running.

Furthermore, it is highly important that, irrespective of circumstances and the volume of supplied air, the cut-out pressure of the governor is periodically reached (at least 6 times per hour) to allow the air dryer element to regenerate while the compressor is running unloaded.

The regeneration cycles of the air dryer should always be adhered to, to avoid the possibility of degeneration of the crystals in the air dryer filter element as a result of unduly frequent and prolonged presence of moisture, and also to prevent freezing in periods of frost.

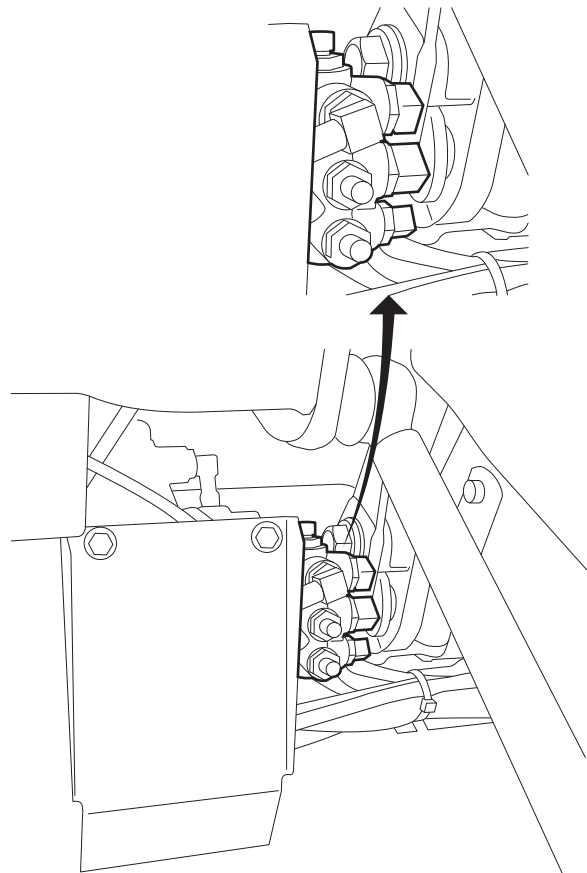

R601304

6

Maximum permitted average air consumption

If the compressor is used in accordance with the method described above, the maximum permitted average air consumption on CF75-85 and XF vehicles is 70 l/min* (continuous operation) at engine speeds = 1200 rpm (XF, CF85) or = 1400 rpm (CF75). The maximum average air consumption on LF and CF65 Series is 35 l/min* at 1200RPM

* Air volume at atmospheric pressure.

To guarantee the full compressor service life time and also meet the statutory requirements for compressed air systems for trucks, it is important that:

- the 25% limit of loaded compressor operation during the load cycle of the air compressor should not be exceeded. This means that during any period of 10 minutes the compressor must not run longer than 2.5 minutes without a break;
- after installation and/or during use of the external air consumption system, the vehicle should fully comply with the ECE-R13/09 (EBS brake system) and 98/12EC (conventional brake systems) directives.

BODYBUILDERS' GUIDELINES

PTO and other energy consumers

If the limit values of the compressor load cycle are exceeded frequently and/or for longer periods, this will lead to increased oil consumption and a shorter service life of the air compressor, the air dryer/element and the governor valve (APU).

If any of the above-mentioned conditions cannot be met, the fitting of a second (external) compressor, combined with a twin-chamber air dryer, is recommended. The second compressor can be driven by a PTO or have its own drive unit. Depending on vehicle type, air system capacity and vehicle options, extra air tanks can be used in combination with increased air dryer capacity.

Extra air consumers in the cab

The coupling for extra air consumers **in the cab** of CF and XF vehicles is shown in the opposite drawing. The air pipes can directly be connected to the unused ports. For reasons of safety, it is not allowed to connect air consumers at other points of the compressed air system.

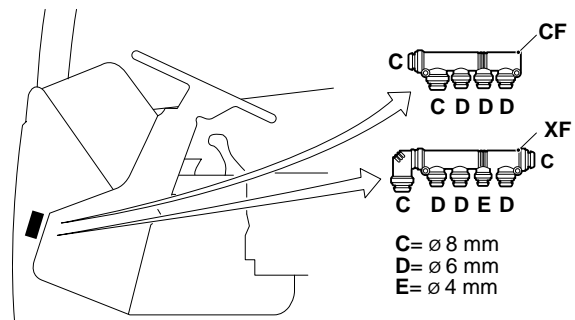

G000308

6

Horn

All CF and XF cabs, including Space Cab versions, are provided with a non-connected 6 mm pipe, running from underneath the driver's seat via the B pillar to the mounting place for a horn on the cab roof above the door on the driver's side.

6.11 AIR FEED, TIPPER PREPARATION

By ordering the option "air feed/tipper preparation" Selco 4331, the cab will be prepared with six air pipes and an indication light, thus preventing unnecessary opening of the cab interior panels.

The air pipes will be positioned from underneath the floor covering under the driver seat, via the threshold and a-pillar through the cab floor next to the steering column. The air pipes will have an outside diameter of 6mm and protrude appr. 1 meter outside the cab.

The tipper indication light will be positioned in the panel at the LHS of the steering wheel, for LHD vehicles. Pin 2 and 3, in the black 12 pole application connector for spare wires for body functions A103, positioned behind the right front mudguard can be used to switch on the indication light.

6.12 HEATING SYSTEM

A heating system for the load area may be connected to the engine cooling system. Its effectiveness depends on the amount of residual heat produced by the engine at that moment. If a heating system is connected to the engine cooling system without any further provisions, this may have an adverse effect on the capacity of the cab heater. An engine which does not reach its operating temperature uses more fuel and, in the longer term, additional engine wear may occur. Critical factors for the engine temperature are a low load collective (low GVM/GCM, level load) and low ambient temperatures.

Conditions:

- Use of a system with a thermostat must ensure that the engine temperature cannot fall below the minimum operating temperature, measured before the thermostat. This body thermostat, if fitted in the supply line, should open at most 5°C earlier than the engine thermostat.
- The present DAF thermostats meet the following criteria:

		LF and CF65 Series	CF series	XF series
Minimum operating temperature		82°C	87°C	79°C
Opening temperature	direct coolant return	82°C - 90°C	85°C - 88°C	85°C - 88°C
	indirect coolant return (Automatic transmission or ZF-Intarder)		81°C - 84°C	81°C - 84°C

- Closing temperature 2 to 3°C lower than opening temperature.
- No more than 10 litres, 5 litres for the LF and CF65 series, may be added to the engine coolant circuit, in view of the available capacity of the header tank (not in the case of transmission cooling).
- The connection to the engine cooling system on CF75/85 and XF series must be made **parallel** to the existing circuit, using pipes with an inside diameter not exceeding 20 mm. The engine cooling system is supplied

BODYBUILDERS' GUIDELINES

PTO and other energy consumers

with external "indirect" coolant line for all superstructure versions. This coolant line contains a 1 1/4" BSP connection, just before the thermostat house, which can be used for connection of supply line for the additional cooling system of the body builder. The return line of this system has to be connected to the coolant pump suction line. In the case of the CF75 series, DAF should be consulted.

- The connection to the engine cooling system on LF and CF65 series must be made **parallel** to the existing circuit, using pipes with an inside diameter not exceeding 15 mm. The coolant feed can be taken from the coolant port on the engine cylinder head, just before the thermostat housing. The return line of this system has to be connected to the coolant pump suction line.

A connection to the existing heater circuit of the engine is advised against in all cases because the (already limited) heater flow will then again be divided, as a result of which line resistance will be increased and the capacity of both systems will be reduced.

6

- The flow through the superstructure circuit is max. 60 l/min., 30 l/min. for LF and CF65 Series. The nominal capacity of the coolant pump averages between 400 and 500 l/min, and around 200 l/min. for LF and CF65 Series, depending on line resistance and pressure.
- Under these conditions, the drop in engine temperature ($\delta T_{\text{engine,av}}$) must not exceed 6°C!
- Pipes should, where possible, be fitted in a straight line, without sagging. Bleed nipples should be provided at the highest points in the system. The complete system must remain positively de-aerating, and must not trap air.
- If desired, the heating system may be supplemented with an auxiliary heater. In that case, an extra header tank should be added to the system (see general arrangement drawing). this auxiliary heater must be controlled such that it cannot increase the cooling load of the vehicle radiator.

System designs must always be submitted to DAF for verification!

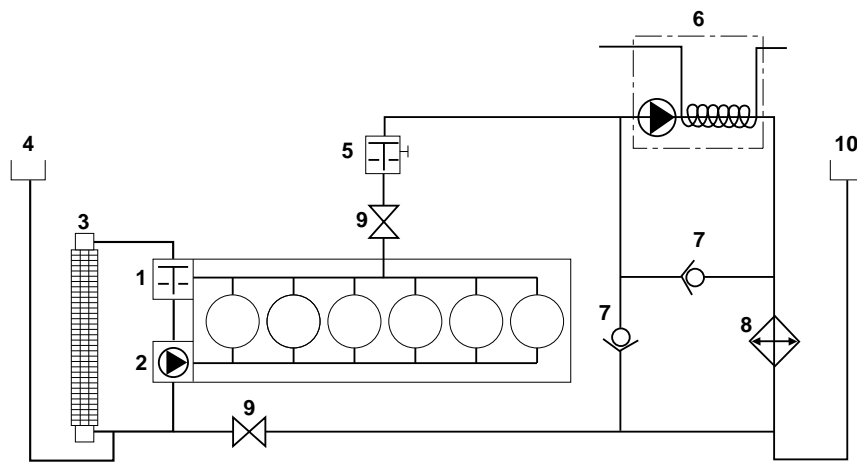

97122901-008

Example of a heating system with extra heating unit

- 1 = engine thermostat
- 2 = coolant pump
- 3 = radiator
- 4 = vehicle header tank
- 5 = superstructure thermostat
- 6 = extra heating unit
- 7 = non-return valves
- 8 = heat exchanger
- 9 = heater valve
- 10 = superstructure header tank

BODYBUILDERS' GUIDELINES

PTO and other energy consumers

6

ELECTRICAL SYSTEM GENERAL

	Page	Date
7.1 General	197	201019
7.2 Safety instruction	197	201019
7.3 Circuit diagram	197	201019
7.4 Earth connections	199	201019
7.5 Wire cross-section and fuse sizes	200	201019
7.6 Charging batteries	201	201019
7.7 Peak voltages	202	201019
7.8 EMC compatibility	202	201019
7.9 Maximum load	204	201019
7.10 Quiescent current	204	201019
7.11 Additional batteries	205	201019
7.12 Additional alternator	206	201019
7.13 Connection points and permitted power loads	206	201019
7.14 DAF dashboardpanel switches and indication lights	208	201019
7.15 Automated and automatic gearboxes	209	201019
7.16 Electrical retarders	212	201019
7.17 Taillift preparation	213	201019
7.18 Axle load monitoring (ALM)	214	201019
7.19 Guideline for the Customer Parameter Change Form	216	201019

BODYBUILDERS' GUIDELINES

Electrical system general

7

7. ELECTRICAL SYSTEM GENERAL

7.1 GENERAL

In many cases, the bodybuilder will connect the electrical system of the vehicle and that of the body, together. It is therefore essential that the following general guidelines be accurately followed, because the slightest disruption could result in failure of the complete system or parts of the system, as a consequence of which the entire vehicle may cease to operate.



WARNING! *It is strictly forbidden to make an electrical connection to the wiring of the vehicle, except via the connection points indicated as such, by DAF. For suitable connection points in the cab and on the chassis, see a description later in this section.*

7.2 SAFETY INSTRUCTION

Electrical equipment added to the electrical system of the chassis may not behave in such a way that the standard system of the chassis, or safety in general, is negatively affected.

Under all circumstances, first disconnect the positive terminal of the battery, when working on the electrical system.



NOTE: For welding work, follow the instructions laid down in section 2.3: "Welding on the chassis"

7.3 CIRCUIT DIAGRAM

For the electrical (circuit) diagrams for DAF vehicles refer to the Sales Engineering department at DAF. Also the local DAF dealer has electrical diagrams available in the workshop manuals.

If applicable, the bodybuilder should make additional circuit diagrams available, which must be added to the other documentation required to be kept in the vehicle. In the event of breakdown and/or repair, this permits more efficient working.

Marking of wiring

The marking system consists of a numerical and a colour coding system, according to which the wiring is clearly classified, and connection and manufacturing errors are avoided.

BODYBUILDERS' GUIDELINES

Electrical system general

The numerical coding consists of four figures, the first figure of which refers to the main group and the colour.

Main group			
Power supply (red)			
1000	upto	1099	Voltage generation
1100	upto	1199	Power supply before contact
1200	upto	1499	Power supply after contact
Lighting (yellow)			
2000	upto	2099	Direction and alarm lighting
2100	upto	2599	External vehicle lighting
2600	upto	2999	Internal vehicle lighting
Warning and control functions (blue)			
3000	upto	3399	Engine functions
3400	upto	3999	Vehicle functions
Consumers (black)			
4000	upto	4499	Start, stop, engine and glowing functions
4500	upto	5499	Vehicle functions
5500	upto	5999	Automatic gearboxes
6000	upto	6999	Special version (not ex-production line; ex-factory)
Earth (white)			
Not marked			
9000	upto	9499	Test and signal earth

LF, CF & XF105 series		
SAE J 1939 / ISO 11898 I-CAN wiring (twisted)		
3565	Dedicated Vehicle Controller-Dash Display	CAN-L (yellow)
3566	Dedicated Vehicle Controller-Dash Display	CAN-H (grey)
SAE J 1939 / ISO 11898 V-CAN wiring (twisted)		
3780	Vehicle CAN bus 1	CAN-L (yellow)
3781	Vehicle CAN bus 1	CAN-H (red)
3700	Vehicle CAN bus 2	CAN-L (yellow)
3701	Vehicle CAN bus 2	CAN-H (blue)
SAE J1939 / ISO 11898 FMS-CAN wiring (twisted)		
3782	D-CAN	CAN-L (yellow)
3783	D-CAN	CAN-H (green)
ISO 11992/2 EBS-CAN wiring (twisted)		
3558	Dedicated EBS Trailer connection	CAN-L (white)
3559	Dedicated EBS Trailer connection	CAN-H (blue)
BB-CAN or CANopen		
3810	BB-CAN	CAN-L (yellow)
3811	BB-CAN	CAN-H (orange)
ISO 11992/3 Truck Trailer interfacing (not for LF)		
3812	Dedicated TT-CAN (truck-trailer) connection ⁽¹⁾	CAN-L (white/brown)
3813	Dedicated TT-CAN (truck-trailer) connection ⁽¹⁾	CAN-H (white/green)

(1) TT-CAN is prepared but not yet released.

7.4 EARTH CONNECTIONS

There are two main ground point locations on a truck. One is located outside the cabin on the flywheel housing and one is located inside the cabin on the bulkhead panel. The main ground wiring is routed from the batteries to the starter motor (or very nearby; flywheel housing). From this point the power ground to the cabin is connected as follows:

1. The ground point on the flywheel housing may only be used for grounding electrical consumers that consume large electrical currents (>20A) and have no connections to the CAN network.
2. The ground point on the bulkhead lead through must be used for grounding all CAN systems and all other "low current" (<20A) or cabin (max40A) systems. If more power than 40A in the cabine is needed an extra ground wire must be routed between flywheel housing and cabin.

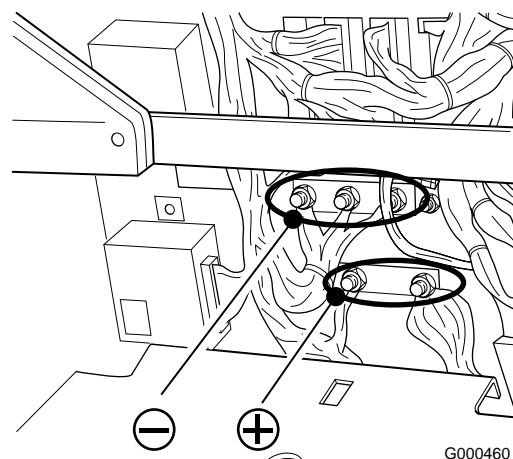

BODYBUILDERS' GUIDELINES

Electrical system general



WARNING! It is not permitted to make a connection (splice) to the white wiring with numerical coding 9000 to 9500. This is the central signal grounding system for all DAF electronic components in the vehicle.



WARNING! It is not allowed to connect any ground wires to other points than the 2 main ground points (e.g. directly on the chassis or cabin body). This is to avoid any ground loops or interference with DAF systems.



WARNING! Grounding directly on the battery ground terminal should also be avoided for the same reason as mentioned above.

7.5 WIRE CROSS-SECTION AND FUSE SIZES

Each wire in the truck should be protected by a fuse that is matching its wire size otherwise melting isolation could occur as a result of overload or short circuit. Separate fuses are needed to avoid result damage when a fuse blows (avoiding loss of system functions that did not cause the fuse to blow). If clustering can not be avoided, the additional function loss must be weighted. As a general rule, clustering is only allowed for similar functions and accessories (not for drive line- and CAN systems). The minimum cross-section of cables is shown in the following table. Above all for higher currents, the cable length should be kept as short as possible.

Cross-section wiring in relation to (continuous) current strength [amp.]				
Wire cross-section [mm ²]	< 3 m.	< 6 m.	< 9m.	> 9 m.
1	9	5	4	-
1.5	22.5	13.5	7.5	6
2.5	37.5	22.5	12.5	10
4	60	36	20	16
6	90	54	30	24
10	150	90	50	40
16	240	144	80	64
25	375	225	125	100
35	525	315	175	140
50	750	450	250	200
70	1050	630	350	280

Cross-section wiring in relation to (continuous) current strength [amp.]				
Wire cross-section [mm ²]	< 3 m.	< 6 m.	< 9m.	> 9 m.
95	1425	855	475	380
120	1800	1080	600	480

The minimum wire cross-section for the connection cable between the starter motor and the batteries depends on the length of the cables. Because for the starter motor cabling, the high current levels are of a short duration only, the permitted current per length category may be increased by a factor of 1.5.

The cable used should be of automotive quality and have temperature resistance upto 120°C minimum.

7.6 CHARGING BATTERIES

When charging the batteries, both battery cables must be disconnected. Then first connect the 'positive clamp' of the charger to the 'positive terminal' of the battery. Then connect the 'negative clamp' to the 'negative terminal'.

Only use a 'quick charger' if the batteries are disconnected from the vehicle. During 'normal charging' (< 28.5 volt charge voltage), the battery clamps may remain connected.

Also ensure a well ventilated environment, and avoid sparks and open flames. Following charging, first switch off the charger. On then remove the 'negative clamp' followed by the 'positive clamp'.



WARNING! The battery cables may not be removed with the engine running.

First allow frozen batteries to defrost, before charging.

Electronic components are extremely sensitive to overloading of the electrical circuit. High voltages or long-term overloading can damage the built-in fuses and subsequently the components in such a way that the components require replacement.



NOTE: If assisted starting is considered please consult on beforehand the appropriate procedure as described in the drivers' manual .

BODYBUILDERS' GUIDELINES

Electrical system general

7.7 PEAK VOLTAGES

Peak voltages

All power consumers to be added must be protected against inductive peak voltages.

A diode protection system according to the following circuit diagram may be installed. Inductive peak voltages at a minimum of 50 Hz may not exceed 40 V. Above this level, the electrical system may be damaged. The protection diode should be positioned as close as possible to the power consumer causing the peak voltages.

See the following circuit diagram

a = fuse

b = switch

c = diode

d = power consumer

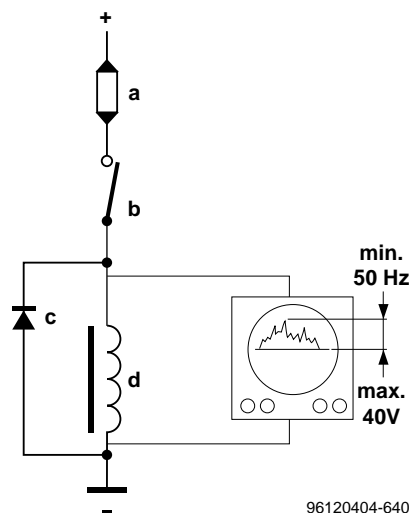

7.8 EMC COMPATIBILITY

Electromagnetic compatibility

Electromagnetic compatibility (EMC) should be taken to mean the degree of insensitivity of electrical systems to electromagnetic interference (EMI). EMI interference can be broken down into the following classifications:

1. Interference caused by magnetic fields which are in principle present close to all electrical appliances. Major sources of interference include transmission masts (e.g. for radio, television and mobile telephony) and electricity pylons.
2. Electromagnetic radiation generated by components in the vehicle itself. Major sources of interference are the generator, electromagnets, motors for electrical window operation, etc. and electronic units.
3. The influence of the systems upon one another, caused by switching signals.

In order to minimise the influence of electromagnetic interference, the bodybuilder should take account of the following points of departure:

- electronic systems added to the DAF chassis must be certified according to EMI legislation 95/54/EEC;
- for every system, a separate power supply wire and earth should be used. Only the power supply points and earths should be used, as described in the DAF After Sales system manuals (see various info in this section);

- the wiring should be positioned as close as possible to the DAF cable harness in the cab and in the chassis; always install the cable harness on the inside of the chassis, in order to prevent external radiation from electromagnetic fields, as far as possible;
- the wiring for components sensitive to EMI (consult with suppliers) must be twisted;
- excessively long wiring must be shortened, and the use of loops must be avoided; by carefully tying the cable harness, sensitivity can be reduced.

Generally speaking, portable telephones and transmitting equipment without an external antenna should not be used in the cab. The extremely high field strengths generated by these appliances in the cab can result in irregular behaviour or failure of electronic systems. Such equipment can also be harmful to health, because of the high electromagnetic fields. Installation should therefore be carried out by approved installation stations, whereby the correct connection of the external antenna must be verified.

The use of handheld portable telephones close to a vehicle with the contact switched on must be avoided.

For 27MC, 2m band and satellite communication equipment, the same applies as for portable telephones.



NOTE: Minimum currents for input and output signals of 8mA is required. The recommended value is 20 mA. This to ensure that no disturbance due to environmental conditions occurs. Also in case of lower currents used, an error detection due to too low load on the wire connected can occur (depending on the application)



*NOTE: Digital input signals comply to IEC1131-2 type 2 inputs, unless otherwise stated.
PNP only
Level0 $U < 5V$
Level1 $U > 11V$*



*NOTE: Digital output signals comply to specification below, unless otherwise stated.
PNP only
Level0 $U < 2V$
Level1 $U > 11V$
Max power see system or application specification*

BODYBUILDERS' GUIDELINES

Electrical system general

7.9 MAXIMUM LOAD

The electrical system may be additionally loaded to the following values:

Chassis type	Maximum extra (continuous) load for electrical system in watts	
	Alternator 80A/24V	Alternator 100A/24V
LF series	35A/840W	45A/1080W
CF series	30A/720W	40A/960W
XF series	15A/360W	25A/600W

The vehicles are equipped with two series-connected batteries. Additional power consumers can be connected at a number of points in the electrical system. In the event of brief high peak loads of the electrical network (>100A), it is recommended that a 2nd battery set be installed. At peak loads of more than 150A, a 2nd battery set must be installed. See section 7.11: "Additional batteries".



WARNING! Additional power consumers must at all times be fitted with a separate fuse. See the sections 9.1: "LF series cab switch and connector locations", 10.1: "CF series cab switch and connector locations" and 11.1: "XF series cab switch and connector locations".

7

7.10 QUIESCENT CURRENT

The required battery size is mainly determined by 2 factors:

1. The vehicle quiescent current
2. The required battery lifetime (which is very much depending on the amount of electrical consumers that are mounted on the vehicle.

The quiescent current is the electrical current that is drawn from the batteries when the vehicle is parked with all the electrical systems shut off. According to the DAF standards it must be possible to start the vehicle at -20°C with 50% discharged batteries. It is also a standard that a vehicle should start after 3 weeks standstill (when parked with fully charged batteries). This means that the maximum total quiescent current for a vehicle is depending on the battery size, configuration and the maximum battery charge level. On a vehicle the maximum reachable charge level is about 85% of the rated capacity. The table below gives an overview for most batteries that are used.

Battery type	Maximum quiescent current
140Ah SHD ⁽¹⁾	97 mA
175Ah SHD	122 mA
225Ah SHD	156 mA

(1) Super Heavy Duty

7.11 ADDITIONAL BATTERIES

The parts required for connecting additional batteries (for example for a tail lift) can be supplied by DAF Parts. Before additional batteries are installed, ensure that the alternator capacity is sufficient to charge all batteries. If this is not the case, a heavier-duty or additional alternator can be installed. The dividing relay should be positioned as close as possible to the additional batteries. The fuse for the additional power consumer will depend on the load. Minimum wire cross-section to second battery is 50 mm².

LF/CF/XF

- a = control relay
- b = dividing relay
- c = diode
- d = fuse
- e = power consumer

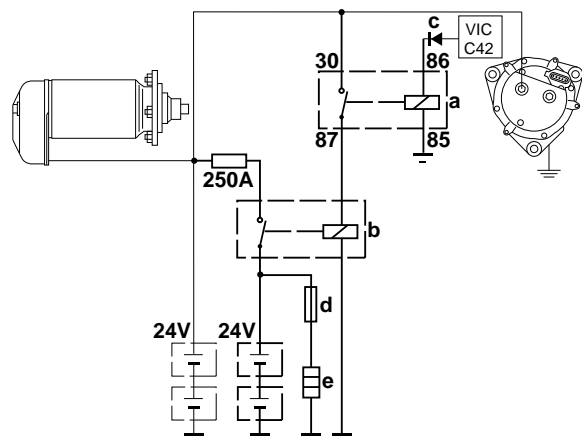

G000283

VIC C42 = engine running signal.

The 'engine running' signal is used for controlling the dividing relay. This signal can be found in the table 'Bulkhead lead-through for body functions' (see section 'Cab connection points' of the LF, CF or XF series).

- On LF wire 3003 on all models
- On CF wire 3157 on all models
- On XF wire 3157 on all models

BODYBUILDERS' GUIDELINES

Electrical system general

7.12 ADDITIONAL ALTERNATOR

It is desirable that the additional alternator has the same capacity as the original alternator, as well as an integrated voltage regulator. Differences in voltage regulation and capacity can result in a shorter service life of one of the two components.

Mechanical damage to electrical components or wiring, in whatever form, must at all times be avoided. Use original cable thickness and connectors.

LF, CF and XF series

Signal VIC D28 (LF series) or D29 (CF and XF series) is the L-signal from the alternator (wire number 1020). This wire is also located in the bulkhead lead-through.



NOTE: This signal also contains diagnosis information from the alternator voltage regulator. The signal is therefore not always 'high' when the engine is running. This makes it less suitable for protection purposes. Moreover, at most one extra mini-relay (150mA 24V) can be connected to it.

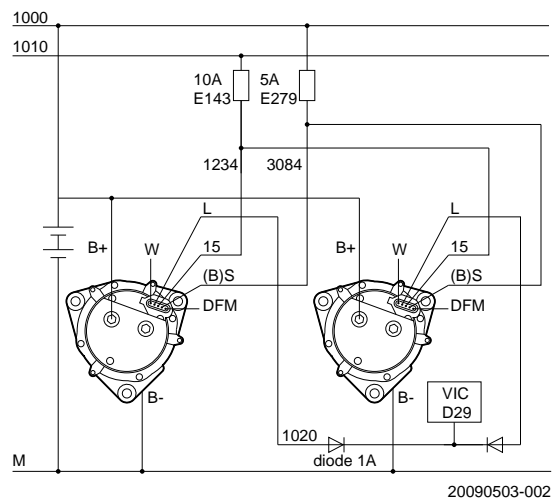

7.13 CONNECTION POINTS AND PERMITTED POWER LOADS

Permitted loads

In the different application connectors power and ground connections for the body builder are available. These power and ground connections are protected by fuses. The power and ground connections in these application connectors can be combined with one and the same fuse. These fuses are used not only for the application power but also for the different vehicle systems. That's why the netto power available for applications is less than the power on the fuse. To protect the electrical installation of the vehicle it is very important to know the maximum allowed total netto power that can be dissipated via the different power connections. In the table below an overview of all the power connections in the different application connectors is made together with the fuses where they are connected to:

Power connections KL30					
fuse	power	wire	application connector	pin nr.	Total Power (netto)
E048	15A	1113	A001 (connector Trailer 7-pole) A058 (connector trailer 15-pole) A070 (connector application superstructure 8-pole) A095 (connector application garbage truck) A117 (connector trailer 13-pole)	4 9 1 5 A	12A
E043	25A	1119	A004 (connector trailer ABS/EBS 7-pole)	1	20A
E036	15A	1103	A007 (connector accessoires 24V 2-pole)	2	12A
E431	5A	1131	A011 (connector accessoires 12V 2-pole)	2	4A
E168	40A	1175	A038 (connector accessories 40A 2-pole)	1	32A
E142	25A	1154	A095 (connector application garbage truck) A102 (connector body builder 8-pole) A105 (connector body builder open CAN 7-pole) A106 (connector CAN-cab 9-pole)	9 1 1 1	16A
E084	10A	1101	A097 (connector FMS 21-pole) A097 (connector FMS 21-pole) A098 (connector FMS 18-pole) A100 (connector HD-OBD diagnosis) A140 (connector extra camera 1-pole)	11 17 17 16 1	8A
E145	15A	1163	A108 (connector diagnosis AGC-A)	B	12A

Power connections KL15					
fuse	power	wire	application connector	pin nr.	Total Power (netto)
E053	10A	1229	A100 (connector HD-OBD diagnosis)	1	8A
E091	15A	1240	A043 (connector driver seat 2-pole) A068 (connector ESC - chassis) A095 (connector application garbage truck) 4C (connector ESC Cabin)	1 12 6 12	12A
E163	25A	1258	A088 (connector Tailift) A095 (connector application garbage truck) A097 (connector FMS 21-pole) A102 (connector body builder 8-pole) A123 (connector Hydraulic Platform) A125 (connector Hydraulic Platform feed through) A138 (connector FMS 12-pole) 12D (connector body builder 21-pole)	4 11 18 2 12 7 10 21	16A



NOTE: Minimum currents for input and output signals of 8mA is required. The recommended value is 20 mA. This to ensure that no disturbance due to environmental conditions (EMC See 7.8: "EMC compatibility") occurs. In case of lower currents used, an error detection due to too low load on the wire connected can occur (depending on the application).

BODYBUILDERS' GUIDELINES

Electrical system general



NOTE: Digital input signals comply to IEC1131-2 type 2 inputs, unless otherwise stated.

*PNP only
Level0 $U < 5V$
Level1 $U > 11V$*



NOTE: Digital output signals comply to specification below, unless otherwise stated.

*PNP only
Level0 $U < 2V$
Level1 $U > 11V$
Max power see system or application specification*

7.14 DAF DASHBOARD PANEL SWITCHES AND INDICATION LIGHTS

The panel switches for the LF, CF and XF series are exchangeable. (the header shelf switches on LF series are not exchangeable with dashboard panel switches)

Switches are available which also have a function indication (LED) in the switch. For an overview of available switch part numbers and symbol glasses, see section 13.9: "Switches".

For more information about the location of the cab switches see the here listed sections:

- Section 9.1: "LF series cab switch and connector locations" for the LF cab
- Section 10.1: "CF series cab switch and connector locations" for the CF cab
- Section 11.1: "XF series cab switch and connector locations" for the XF cab



NOTE: Current series LF, CF and XF have all amber LED illumination as search light. This is not suited as function indication.



NOTE: For indication lamps, a lamp holder with two lamps (24V) is available, in the shape of a switch. Additional indication lamps can therefore be placed in the dashboard, in design style. Identical symbol glasses as used with the switches can be used here.

Next to this a LED indication (single red LED) in similar housing is available. See section 13.8: "Indication lamps" .

7.15 AUTOMATED AND AUTOMATIC GEARBOXES

LF series and CF65

The LF series and CF65 offer both automated and automatic transmissions. These gearboxes do not have an application connector as standard.

CF75 and CF85 series

Vehicles fitted with an Allison automatic gearbox, are as standard equipped with an 2-pole application connector (connector code 175C) in the central box in the cab.

There will be three executions available;

1. Refuse collector application
2. Fire brigade application
3. Standard application

REFUSE COLLECTOR APPLICATION

Software package 126.

Specific features are :

- Auto neutral-auto drive function for Stop&Go
- Shifting form forward to reverse or reverse to forward gear only enabled at vehicle speed below 3km/h and engine speed below 900 RPM.
- 6 speed setup

STANDARD APPLICATION

Software package 127.

Specific features are:

- For all application not being refuse or fire brigade
- Shifting form froward to reverse or reverse to forward gear only enabled at vehicle speed below 3km/h and engine speed below 900 RPM
- 6 speed setup

FIRE BRIGADE APPLICATION

Software package 127.

Specific features are:

- Auto neutral function
- Shifting form froward to reverse or reverse to forward gear only enabled at vehicle speed up to 8km/h and engine speed below 900 RPM
- No auto drive function
- 5 gear setup

The following functions are prepared as standard, ex-factory:

1. Automatic neutral with PTO
2. Automatic neutral when stationary and PTO
3. Foot board protection (combined with Vmax application)

BODYBUILDERS' GUIDELINES

Electrical system general

AUTOMATIC NEUTRAL WITH PTO

This facility is standard on all vehicles with a PTO controlled via the Body Builder Module (BBM), and is intended for fire engines.

To prevent pumping being carried out whilst the transmission is in "DRIVE", the transmission is forced into neutral. To shift back to "Drive", the driver must first switch off the PTO, the engine speed must be below 900 rpm, and "D" must be pressed on the shift selector.

If this function is required (refuse vehicle), it has to be enabled in the BBM using DAVIE XD for programming customer parameters. The function can be enabled for PTO1 and PTO2 separately.

AUTOMATIC NEUTRAL WITH ESC

This facility is standard on all vehicles with a PTO controlled via the Body Builder Module (BBM), and is intended for fire engines.

To prevent pumping being carried out whilst the transmission is in "DRIVE", the transmission is forced into neutral. To shift back to "Drive", the driver must first switch off the PTO, the engine speed must be below 900 rpm, and "D" must be pressed on the shift selector.

If this function is required (refuse vehicle), it has to be enabled in the BBM using DAVIE XD for programming customer parameters.

AUTOMATIC NEUTRAL WITH PARKBRAKE

This facility is standard on all vehicles with a PTO controlled via the Body Builder Module (BBM).

To prevent heating up the torque converter or pumping being carried out whilst the transmission is in "DRIVE", the transmission is forced into neutral. To shift back to "Drive", the driver must first switch off the PTO, the engine speed must be below 900 rpm, and "D" must be pressed on the shift selector.

If this function is required (refuse vehicle), it has to be enabled in the BBM using DAVIE XD for programming customer parameters.

AUTOMATIC NEUTRAL POSITION WHEN STATIONARY (and operating PTO)

This option is not available ex-factory, but is prepared. If this function is required (refuse vehicle), it has to be enabled in the BBM using DAVIE XD for programming customer parameters.

Ensure that this function cannot be used in combination with the function AUTOMATIC NEUTRAL WITH PTO.

The function is intended for refuse vehicles. It provides for the selection of neutral if the PTO is operated, the brake pedal is operated and the vehicle is stationary. The transmission remains in neutral until "DRIVE" is selected.

FOOT BOARD PROTECTION

The foot board switch (EN1501) can be connected to the transmission control system. If this is done, the transmission can only be set to neutral or first gear.

This functionality is available only in combination with the option "Refuse prepared" (see chapter 10.19: "Refuse preparation CF75 - CF85 Series").

The maximum vehicle speed must be set in the engine management system (Vmax application see chapter 10.13: "CF65 series ESC system").

PTO OPERATION PARAMETERS

If the transmission is fitted with a switchable (on/off) PTO on the transmission, the PTO operation is controlled by a number of parameters, which together constitute the cut-in and cut-out conditions as used within the ALLISON control unit. Next to this the interlocks in the BBM are valid. See chapter 10.18: "CF series PTO control / protection".

Overview of cut-in and cut-out conditions for PTO's			
Parameter	Standard setting	Limit values	Notes
Maximum engine speed for PTO ⁽¹⁾ cut-in	1163 rpm	500 - 1940 rpm	PTO protection < (1400 rpm/PTO ratio)
Maximum drive shaft speed for PTO cut-in	250 rpm	60 - 5000 rpm	
Maximum engine speed during ⁽²⁾ PTO operation	4000 rpm	380 - 4000 rpm	
Maximum drive shaft speed during PTO operation	1500 rpm	60 - 5000 rpm	

(1) The PTO can only be switched on if both the engine speed and the drive shaft speed are lower than the pre-programmed parameter value.

(2) The PTO is automatically switched off if either the engine speed or the drive shaft speed exceed the pre-programmed parameter.

INCREASED ENGINE SPEED

If the engine is operating at an increased engine speed, and the vehicle is stationary, the automatic gearbox should be in neutral. This means that the activation of an increased engine speed should also be passed on to the transmission control system.

To make sure this happens we advise to activate the "Enable engine speed control" or " Enable N_variable" with wire 5149 in connector 4D (see chapter 12.6: "Connector 4C ESC system").

BODYBUILDERS' GUIDELINES

Electrical system general

Note: In fire engine application the use of this function may differ from that in other vehicle applications.

For all other applications, the selection of increased engine speed must be passed on to the transmission control system. This is for two reasons:

1. When the engine is running at increased speed, and the vehicle is stationary, the transmission must be in neutral.
2. If the vehicle is required to drive with Nvariable, N1, N2, or N3 active, it is necessary that the transmission briefly interrupts the increased engine speed when switching from neutral to "DRIVE". This is not possible at engine speeds higher than 900 rpm.

re1) ESC in neutral position

To ensure that the neutral position is selected when the ESC functions are activated,

re2) ESC during "DRIVE"

This function is possible, but can result in serious problems.

If additional braking is required, because a lower speed than creep speed is required, the interlocks of the ESC function will cause the ESC to be disabled. Re-engagement will be necessary. On the other hand, there is also a risk of overheating the transmission oil, if the engine speed is too high in relation to speed. The MAXIMUM limit applicable here is 1000 rpm for a MAXIMUM of 60 sec. If this becomes relevant, activation of the function AUTOMATIC NEUTRAL POSITION WHEN STATIONARY is always recommended.

If one of the standard settings does not agree with the desired application please consult DAF.

XF series

The XF series is only available with automated AS-Tronic gearboxes. For control, protection and settings, see section 11.16: "XF series PTO controls / protection".

7.16 ELECTRICAL RETARDERS

The installation of an electrical retarder on the gearbox or in the driveline requires a 'statement of no objection' from DAF. The installation drawing (to be submitted in duplicate) should show the following details:

- position of the retarder,
- position and angles of the driveline,

- power supply,
- freedom of movement,
- suspension of the retarder on the chassis,
- performance of the retarder,
- retarder cooling, if applicable,
- shielding of heat-sensitive components (such as pipes).



WARNING! On vehicles with EBS braking system it must be investigated how the installation can be done in such manner that the service braking system is not influenced. Always contact DAF for support.

For the installation of non-electrical retarders, DAF should also be consulted. Software modifications will very likely be necessary. Contact DAF for support.



NOTE: *The software needed to achieve desired functionality may not be available yet, but is released on demand. This means that leadtime may be upto 6 weeks. Please make your enquiries in time!*

7.17 TAILLIFT PREPARATION

As an option a preparation for connecting a taillift is available for CF65/75/85 and XF. By ordering the option, Application connector taillift, the vehicle will be equipped with chassis wiring and cab electric's, including starter interrupt when taillift is open, off/standby switch and 2 indication lamps on a switch position.

Application

The connector has been defined by the VEHH. The VEHH is a group of European Taillift manufacturers, which consists of participants: AMF, Bär, Behrens, Dautel, Dhollandia, MBB, Meiller and Sørensen. The 7-pole connector is located on the back of the chassis.

Check section 12.29: "Connector A088 taillift system 7-pole" for additional information on pinning and wire numbers within this connector used.

Check section 12.11: "Connector 12D body builder" for additional information on pinning and wire numbers within this connector used.

BODYBUILDERS' GUIDELINES

Electrical system general

7.18 AXLE LOAD MONITORING (ALM)

General

Axle Load monitoring is an option on CF75/85 and XF series (not available on the CF65 Series). This system allows you to read the actual axle loads. The system uses pressure sensors that are mounted in the air bellows and that convert the pressure into tons. The weight of the load can be determined on the basis of these axle loads. The information menu on the master display shows the actual axle load for each axle. The axle load is only shown when the ignition is turned on and the vehicle is stationary.

Axle load information

FT vehicles

In the menu, select 'axle load information' to display the axle loads. The displayed axle load (A) is the overall weight on the axle (load + own weight). The displayed axle load (A) on a vehicle with a leaf-sprung front axle is calculated by the system.

If a small arrow (B) is shown in the bottom right-hand corner of the display, the menu selection switch can be used to retrieve information on the semi-trailer.

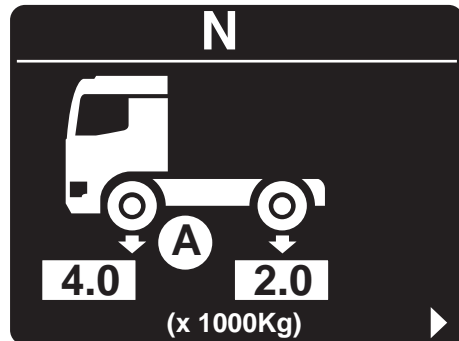

Semi-trailers

In order to display the axle loads on a semi-trailer, the following conditions have to be met: The semi-trailer must have an EBS brake system or air suspension that supports axle load monitoring.

On semi-trailers with axle load monitoring, all individual axle loads are shown.

On semi-trailers without axle load monitoring but with EBS, only the overall axle load of all axles is shown in the display.

On semi-trailers with neither EBS nor axle load monitoring only the axle load of the prime mover is shown.

If a small arrow (C) is shown in the bottom left-hand corner of the display, the menu selection switch can be used to retrieve information on the prime mover.

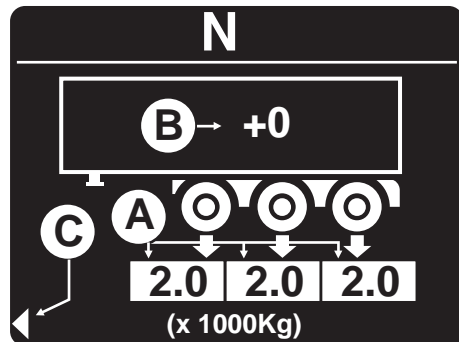

FA vehicles

When the 'axle load information' function is selected in the menu, a number of axle loads (A) are either or not shown, depending on the vehicle configuration. The value (B) which is displayed in the vehicle, indicates the weight of the load.

It depends on the type of the vehicle whether or not the axle load values are shown. For instance, the axle load on a leaf-sprung front axle is not shown. All the axle loads on a fully air suspended prime mover are always shown.

If a small arrow (C) is shown in the bottom right-hand corner of the display, the menu selection switch can be used to retrieve information on the semi-trailer.

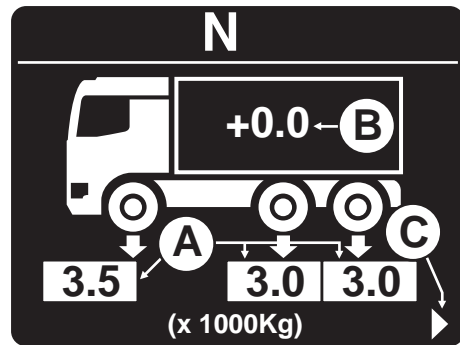

D001151

Trailer

In order to display the axle loads on a trailer, the following conditions have to be met: The trailer must have an EBS brake system or air suspension that supports axle load monitoring. On a trailer with axle load monitoring, all individual axle loads are shown.

On a trailer without axle load monitoring but with EBS, only the overall axle load of all axles is shown in the display.

On a trailer with neither EBS nor axle load monitoring only the axle load of the prime mover is shown.

If a small arrow (C) is shown in the bottom left-hand corner of the display, the menu selection switch can be used to retrieve information on the prime mover.

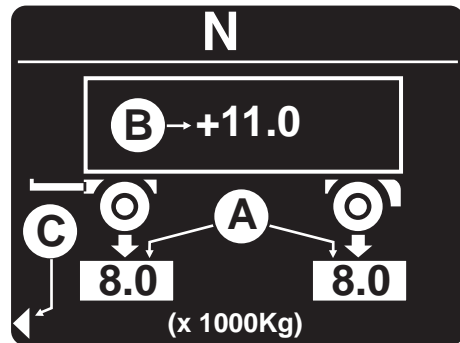

D001155

Reset loading weight

When the 'reset loading weight' function is selected, the actual axle load (A) will be used as a reference.

In this way it can be determined how much weight has been added or removed. Reset will put the loading weight (B) on 0.0. When the vehicle is loaded or unloaded, the indicate loading weight will increase or decrease.

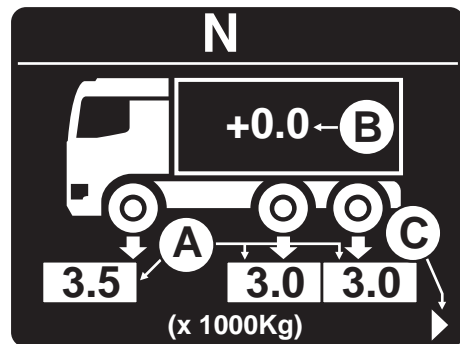

D001151

Axle overload warning

When the maximum load for an axle is exceeded, a warning will be shown on the master display. This warning can be suppressed by pressing the menu selection switch.

Each time the warning is suppressed by means of the menu selection switch, the value for the maximum load is increased by 500 kg.

It is advised to set the value for the maximum axle load somewhat below the legal maximum axle load.

BODYBUILDERS' GUIDELINES

Electrical system general

The DAF Service dealer can set the value for the maximum axle load.

7.19 GUIDELINE FOR THE CUSTOMER PARAMETER CHANGE FORM

This information highlights the existence and purpose of the customer parameter change form(s) that can be used by bodybuilders to inform a DAF dealer of changes that have to be made in the customer parameter list in order to effectively store this information. Please note that the parameter change forms list only a few of the Customer Parameter ID's available within the different ECU units. Contact the DAF Dealer for more information.

Demonstrated in the illustration at the end of this section is that by completing the ID-card change procedure all changed parameter information will be stored in the DAF After Sales RAPIDO parts file system.

Purpose of the parameter change form

The customer parameter change form aims to support the communication between bodybuilder and DAF Dealer by providing a standardised form wherein all wishes and implemented changes can be documented and made ready for easy archiving into the After Sales RAPIDO parts file system.

Using the customer parameter change form is strongly advised to ensure that the service settings of these parameters are not lost and always available for the complete DAF service network.

Work method

DAF dealers, being the actual ECU programmers via the DAVIE-XD service analyzing tool, receive the completed parameter change form from the bodybuilder/customer. The here mentioned issues are to be considered before submitting the form:

- Choose the right parameter change form for the vehicle series at hand as both forms list different customer parameter ID's and ECU designations. The empty tables at the end of the parameter change form can be used for expanding the list of changes if needed.
The parameter change forms can be downloaded from the "Information Sheet" webpage that is part of the Bodybuilder webpages.
(The Internet URL for the corporate DAF website is: www.daf.com -> follow the main menu item: "Products" -> Bodybuilder guidelines webpage -> Information Sheet webpage).
- All parties involved should sign the parameter change form to confirm correct communication and programming of the ECU units and preferably store a copy of it at the dealership, the bodybuilder and in the serviced vehicle itself.
- It is strongly advised to add a detailed description of the changes that are proposed to enable better understanding of the chosen parameter settings/values by all parties. Important: DAF headquarters can archive your settings but will not evaluate the created parameter configuration; this remains at all time the responsibility of the DAF dealer and bodybuilder/customer.
- Enabling specific functionality may require changed values/settings for several customer parameters simultaneously within the same or possibly another ECU unit.
- Please use the "✓" symbol to clearly indicate your choices.

ID-card change procedure

The changed parameter settings can be communicated to DAF headquarters by the DAF Dealer with the 'MESSAGE' form that is part of the After Sales RAPIDO parts file system. The submitted 'MESSAGE' form will initiate the RAPIDO database file update and distribution to the DAF dealer network.

Important:

- Changed customer parameter settings/values that are communicated to DAF will be stored in free text fields within the RAPIDO parts file system and DO NOT REPLACE the factory default parameter settings within the database file itself.
- During reprogramming of a ECU unit a choice must be made whether to overwrite **all** (changed and unchanged) customer parameters present in the ECU's with the default values as they were ex-factory or only **the unchanged** ones.

BODYBUILDERS' GUIDELINES

Electrical system general

7

DATA COMMUNICATION SYSTEMS

	Page	Date
8.1 Data communication CAN SAE J1939 / ISO 11898 (including FMS)	221	201019
8.2 Data communication CANopen	224	201019
8.3 Data communication ISO 11992/2 & 11992/3	225	201019
8.4 Body Builders' Module (Optional)	226	201019
8.5 CVSG type gauges	227	201019
8.6 Body Builders' CAN J1939	228	201019

BODYBUILDERS' GUIDELINES

Data communication systems

8

8. DATA COMMUNICATION SYSTEMS

8.1 DATA COMMUNICATION CAN SAE J1939 / ISO 11898 (INCLUDING FMS)

In the **LF, CF and XF series**, in addition to the already known systems, a number of new systems are used. These systems are intended to further increase ease of use, effectiveness and safety of the vehicle. The components including these systems are generally installed in the cab. Examples of these new systems (with appropriate abbreviations) are the following:

- Vehicle Intelligence Centre (VIC-3)
- DAF Instrument Pack (DIP-4)
- Engine management FR and GRPACCAR-Cummins engines (ECS-DC5)
- Engine management MX and PR engine (DMCI)
- Body Builders' Module (BBM)
- Controller Area Network (CAN databus)

VIC/DIP

The VIC-3 is the central processing unit from where all information is co-ordinated. The function of the VIC-3 includes converting the information received from vehicle systems, switches, sensors, etc. into protocols for the various vehicle systems, and subsequently passing on this information, in coded form. For example, in this way all information is exchanged with the instrument panel. Together with the protocols, messages are placed on the CAN network (CAN databus) in order of importance. At DAF, use is made of multiple CAN networks, namely the V(ehicle)-CAN 1 and 2, the I(nstrument)-CAN, the D(iagnosis)-CAN and the B(ody)B(uilder)-CAN. The VIC is connected to the vehicle system via the V-CAN, and the electronic instrument panel (DIP-4) via the I-CAN. The V-CAN-2 and BB-CAN are not in the architecture of the LF series electronics.

CAN-bus

The CAN databus is in principle a distribution network of various electronic signals. The pulsed digital signals represent coded messages. These can be transmitted, received and processed by all systems connected to the network. Each system takes up the information it requires, from the network. In this way, a signal which is generated by one system can also be used by other systems. In addition, each network consists of two lines: CAN-H (high) and CAN-L (low). The wires for these two lines are twisted (without

BODYBUILDERS' GUIDELINES

Data communication systems

shielding) in order to prevent magnetic influence from one another and from outside. CAN wiring is therefore always recognisable, by the twisting and the colour; see also "Marking of wiring" in section 7.3: "Circuit diagram".

In the automotive industry, a worldwide standard has been selected for communication (coded messages) between electronic systems:

- SAE J1939/21 (Society of Automotive Engineers) - cabling + network
- SAE J1939/71 (Society of Automotive Engineers) - messages + protocol handling

ISO 11898 is the European equivalent of the SAE J1939 standard. DAF has opted for the 250kB CAN 2.0B protocol application.

In addition, there is a further CAN connection for the EBS system, which operates according to the ISO 11992 standard.

Also at DAF, these international agreements are complied with. For the bodybuilder, there is a further possibility of using the existing CAN network, if the electrical system of the body operates using the same message structure and CAN communication. The V-CAN information is optionally available (via the CAN Connection Unit) in the 21-pin body connector, in the bulkhead lead-through or in the application connector for the superstructure in the chassis. See also the sections 9.2: "LF series bulkhead connections", 10.2: "CF series bulkhead connection overview", 11.2: "XF series bulkhead connection overview" and 8.4: "Body Builders' Module (Optional)".

For more information relating to message structure and accessibility of the V-CAN, contact DAF.

The alteration of existing cable harnesses in the vehicle, other than indicated in the bodybuilding guidelines, is not permitted! There is a possibility that the CAN network will thus be weakened or interrupted, resulting in possible unsafe, but certainly at least in unreliable situations.



WARNING! *Direct connection to CAN bus system for the purpose of retrieving operating data or with other purposes is not allowed since it can interfere with the correct functionality of the truck systems, for example engine or brakes. In case of a direct connection DAF reserves the right to withdraw any warranty on the product or to consider it null and void. At the same time DAF shall not be subject to product liability arising from any direct connection made by a third party.*

FMS Standard

FMS stands for Fleet Management Systems. The main chassis manufacturers, including DAF, have together agreed on the DATA to be universally provided for these FMS systems via the CAN link. Up to date information can be found on the internet at www.fms-standard.com. See chapters 9.12: "LF series FMS system" and 10.17: "CF75 - 85 series FMS / DTS system" for more information.

Important:

Any information (functions/data) supplied must be compiled in accordance with the definitions of the FMS standard.

If functions/data are not available, they should be passed on as 'not available' (NACK).



NOTE: Since the CAN data is depending on which systems are in the vehicle, and again the CAN data is depending on the specification week (software status) of the vehicle, please contact DAF for exact information on the CAN data available on a specific vehicle.

For general information on CAN messages and signals available as options FMS or BB-CAN are chosen, please contact DAF.



NOTE: In case the number of CAN messages in the FMS preparation ex-factory are not sufficient, an extended package can be supplied via DAF After Sales. Please contact DAF in those cases the extended package is required.

8.2 DATA COMMUNICATION CANOPEN

In the **CF & XF series**, in addition to the already known systems, a number of new systems are used.

CAN-bus

The CAN databus is in principle a distribution network of various electronic signals. The pulsed digital signals represent coded messages. These can be transmitted, received and processed by all systems connected to the network. Each system takes up the information it requires, from the network. In this way, a signal which is generated by one system can also be used by other systems. In addition, each network consists of two lines: CAN-H (high) and CAN-L (low). The wires for these two lines are twisted (without shielding) in order to prevent magnetic influence from one another and from outside. CAN wiring is therefore always recognisable, by the twisting and the colour; see also "Marking of wiring" in section 7.3: "Circuit diagram").

In the automotive industry, a worldwide standard has been selected for communication (coded messages) between electronic systems:

- SAE J1939/21 (Society of Automotive Engineers) - cabling + network
- SAE J1939/71 (Society of Automotive Engineers) - messages + protocol handling

ISO 11898 is the European equivalent of the SAE J1939 standard. DAF has opted for the 250kB CAN 2.0B protocol application.

CANopen uses the same interface hardware, but also a completely different software protocol. Since a lot of devices on CANopen are available (from chemical process industry) on 24V power supply, applications can be expected on short term.

The CF75/85 & XF105 series are prepared for CANopen applications. Application is pending on standardisation of the protocol.

Information on the protocols can be found at the Internet, CAN in Automation website **www.can-cia.de**.

For more information relating to message structure and accessibility of CANopen, contact DAF.

8.3 DATA COMMUNICATION ISO 11992/2 & 11992/3

In the **CF and XF series**, in addition to the already known systems, a number of new systems are used. These systems are intended to further increase ease of use, effectiveness and safety of the vehicle.

The CF and XF series are prepared for ISO11992/3 applications.

CAN-bus

The CAN databus is in principle a distribution network of various electronic signals. The pulsed digital signals represent coded messages. These can be transmitted, received and processed by all systems connected to the network. Each system takes up the information it requires, from the network. In this way, a signal which is generated by one system can also be used by other systems. In addition, each network consists of two lines: CAN-H (high) and CAN-L (low). The wires for these two lines are twisted (without shielding) in order to prevent magnetic influence from one another and from outside. CAN wiring is therefore always recognisable, by the twisting and the colour; see also "Marking of wiring" in section 7.3: "Circuit diagram").

In the automotive industry, a worldwide standard has been selected for communication (coded messages) between electronic systems:

- SAE J1939/21 (Society of Automotive Engineers) - cabling + network
- SAE J1939/71 (Society of Automotive Engineers) - messages + protocol handling

ISO 11898 is the European equivalent of the SAE J1939 standard. DAF has opted for the 250kB CAN 2.0B protocol application.

In addition, there is a further CAN connection for the EBS system, which operates according to the ISO 11992 standard.

Also at DAF, these international agreements are complied with. For the bodybuilder, there is a further possibility of using the existing CAN network. The ISO 11992/3 CANbus is one of these system options.

The CF & XF105 series are prepared for 11992/3 applications. Application is pending on standardisation of the protocol.

Information on the protocols can be found at the internet, International Standards Organisation website www.iso.org.

For more information relating to message structure and accessibility of the 11992/3 Truck-Trailer CANbus, contact DAF.

BODYBUILDERS' GUIDELINES

Data communication systems

8.4 BODY BUILDERS' MODULE (OPTIONAL)

Bodybuilders have expressed a strong wish for a clearly separated vehicle/body interface, which is also highly standardised.

With the advent of network structures in the **LF, CF and XF Euro 4/5 series**, and the accompanying increased complexity, the limiting conditions according to which bodybuilders and end users must comply in respect of the interfacing of their systems from and to the vehicle, have further changed.



WARNING! Partly as a consequence of ever increasing reliability requirements, unmonitored working on existing vehicle systems is absolutely undesirable!

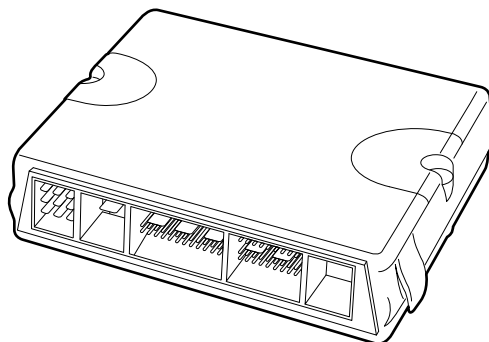

E502263

DAF responded to this demand by developing the Body Builder Module (BBM).

Using these systems, for example, the following functions can be offered:

- Icons and warnings displayed on a DOT matrix screen (dashboard).
- PTO-2 hour counter (only available via CAN).
Only one PTO counter available for the LF Series (which counts PTO1 and PTO2 hours together).
- Improved accessibility to various signals (including engine speed and vehicle speed signal).
- Various temperature signals.
- Tailor-made engine speed control functions.
- Torque and/or engine speed intervention from body.
- Full PTO control from body.
- Cable limitation between body and vehicle.
- Integration of body-PLC controls.
- Implementation of trip, PTO or engine collective meter.
- Etc, etc.

All CF and XF vehicles with the option Engine Speed Control, or PTO, or BodyBuilder CAN are equipped with a BBM.

For more information about applications please contact DAF.

8.5 CVSG TYPE GAUGES

The Body Builder Module (BBM) has an output called CVSG (Commercial Vehicle Slave Gauge). This is a communication bus. The CVSG bus is a single wire communication bus coming from the BBM. With this CVSG bus we can control several gauges, and by using the BBM application area (software) it is possible to translate for example signals available on the vehicle CAN link to an indication gauge on the superstructure control panel.

Dedicated gauges available

Description	Range Metric units	Range Imperial units
Primary air pressure	0 - 10 bar	0 - 150 psi
Secondary air pressure	0 - 10 bar	0 - 150 psi
Engine oil pressure	0 - 7 bar	0 - 100 psi
Engine coolant temperature	40 - 120 °C	100 - 250 °F
Engine oil temperature	40 - 150 °C	100 - 300 °F
Main trans oil temperature	65 - 150 °C	150 - 300 °F
Fuel level #1	E - 1/2 - F	E - 1/2 - F

Gauges not supported by the BBM module (ex-factory)

Description	Range Metric units	Range Imperial units
Application air pressure	0 - 10 bar	0 - 150 psi
Transfer case oil temperature	40 - 150 °C	not available
General oil temperature	40 - 150 °C	not available
PTO oil temperature	40 - 150 °C	100 - 300 °F

General gauges available

Description	Range
Engine RPM	0 - 3000 RPM
Voltmeter	18V-36V
Ampere	-150A - +150A
Hourmeter	0 - 999999 hours
Clock	Analog
Transmission display (Allison Gearbox)	

All gauges have a 52 mm diameter, chrome bezel, black scale with white printing, red pointer, white backlighting, and red indication LED. This red indication LED burns when something is wrong with concerned signal. Together with this red light an indication on the DIP shows a fault. Recommended panel cut-out is 52,5 mm.

BODYBUILDERS' GUIDELINES

Data communication systems

The power supply of the gauges is +12V. Not only an additional DC/DC converter should be applied but also a time relays has to be mounted in the relais foot of the power supply cable of the CVSG gauges. See chapter 13.13: "Miscellaneous parts" for part number information.

This 12V supply and databus connection can be found in the bulkhead lead-through if the CVSG system and BBM unit are specified for the chassis. See chapters 9.2: "LF series bulkhead connections", 10.2: "CF series bulkhead connection overview" and/or 11.2: "XF series bulkhead connection overview" for the wire number and pin location.

Every CVSG gauge has two 4 pin connectors on the back side. Pins 1 to 4 of connector A are bridged to pins 1 to 4 of connector B.

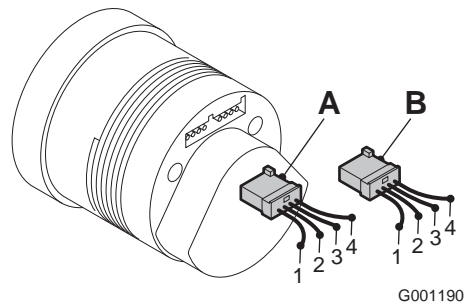

NOTE: In order to get the 12V power supply available, an additional DC/DC converter has to be placed inside the cab - co drivers side. These part numbers and additional items can be found in 13.10: "CVSG Gauges".

Pinning for connector A and B

Pin	Function
1	Data link (CVSG protocol) BBM required
2	Backlighting for no BBM required gauges
3	Ground connection
4	Power supply +12 V

8

8.6 BODY BUILDERS' CAN J1939

Following market developments and demands, DAF can offer an additional feature regarding CAN control to Body Builders.

For CF and XF series vehicles the connection points can be found in the bulkhead connector 12D and application connector chassis BB-CAN A105. See the chapters 10.2: "CF series bulkhead connection overview", 12.37: "Connector A105 Bodybuilder CAN system 7-pole", 11.2: "XF series bulkhead connection overview".



NOTE: For detailed message content see the "BB-CAN CAN message overview.pdf" document on the information sheet web page. (The Internet URL for the corporate DAF website is: www.daf.com -> follow the main menu item: "Products" -> Bodybuilder guidelines webpage -> Information Sheet webpage)



NOTE: All data is according SAE J1939 and detailed information can be found in the "BB-CAN message overview.pdf" on the information sheet web page. (The Internet URL for the corporate DAF website is: www.daf.com -> follow the main menu item: "Products" -> Bodybuilder guidelines webpage -> Information Sheet webpage)

BODYBUILDERS' GUIDELINES

Data communication systems

8

ELECTRICAL SYSTEM LF SERIES

	Page	Date
9.1 LF series cab switch and connector locations	233	201019
9.2 LF series bulkhead connections	234	201019
9.3 LF and CF65 series chassis connections	235	201019
9.4 LF series accessories connection headershelf	237	201019
9.5 LF series accessories connection dashboard	237	201019
9.6 LF series power supply	238	201019
9.7 LF series radio preparation	238	201019
9.8 LF series telephone preparation	239	201019
9.9 LF series anti-theft protection	240	201019
9.10 LF series ESC control	240	201019
9.11 LF series PTO control / protection	252	201019
9.12 LF series FMS system	257	201019
9.13 Refuse preparation LF Series	260	201019
9.14 LF series trailer connection points	265	201019

BODYBUILDERS' GUIDELINES

Electrical system LF series

9. ELECTRICAL SYSTEM LF SERIES

9.1 LF SERIES CAB SWITCH AND CONNECTOR LOCATIONS



WARNING! This paragraph explains for each vehicle series which connection points for additional power consumers are or are not fully or partially prepared ex-factory. Power supplies other than listed in this section, only in consultation with DAF.

Switch positions, overhead console

- 1 Rotating beam switch
- 2 Interior alarm on/off switch
- 3 System LED - Alarmsystem
- 4 Spare
- 5 Spare

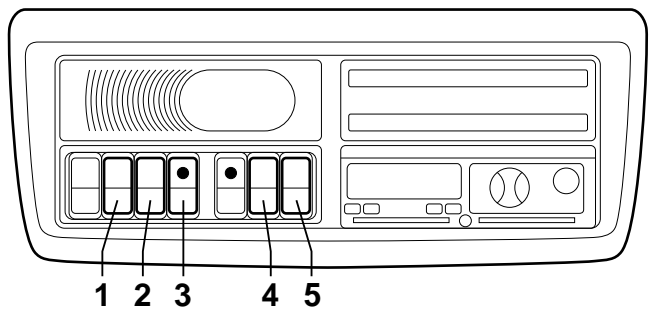

G000434

Switch positions, dashboard

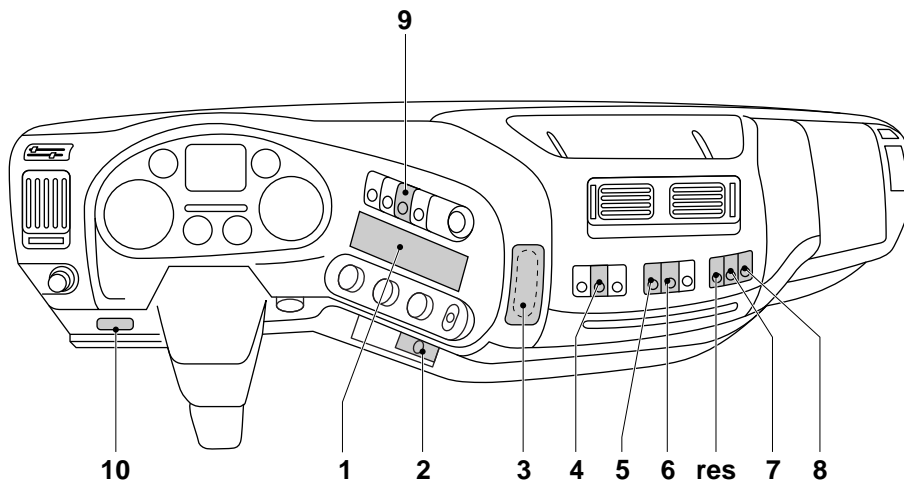

- 1 radio recess
- 2 accessory plug 12V/10A
- 3 telephone location
- 4 work lamp/body lighting
- 5 reversing buzzer on/off
- 6 main switch
- 7 PTO on/off
- 8 loading door alarm on/off
- 9 adjustable speed limiter

G000433

BODYBUILDERS' GUIDELINES

Electrical system LF series

- 10 Location of the FMS and HD-OBD connector. See sections 12.44: "Connector A126 FMS 2-pole" and 12.33: "Connector A100 HD-OBD diagnose" for more information.

RES reserve point

9.2 LF SERIES BULKHEAD CONNECTIONS

Locations of application connectors

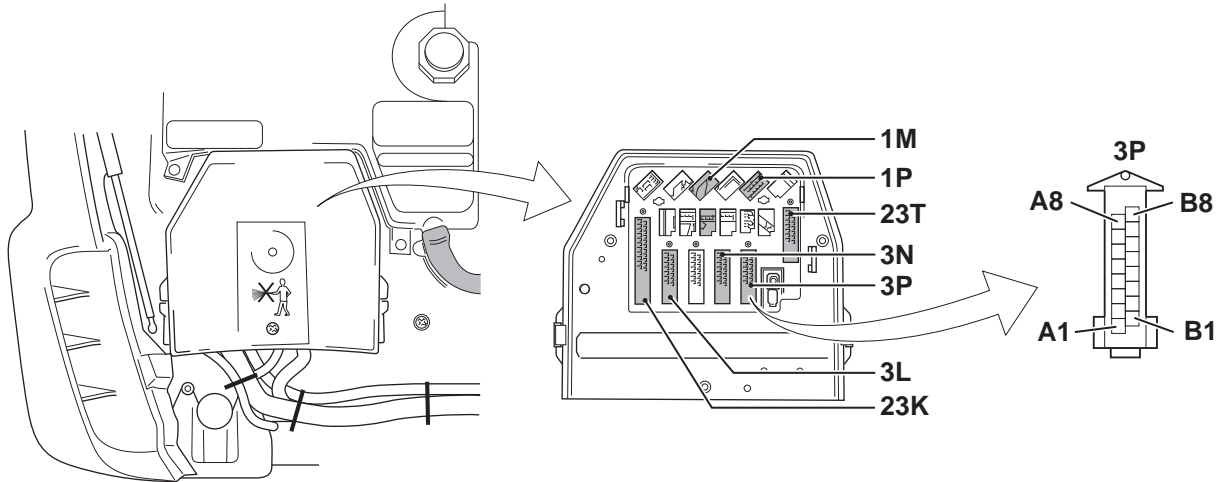

G000535

Connector Code	Descriptions ⁽¹⁾
1M	Application connector for spare wiring, see section: 12.1: "Connector 1M spare wiring"
1P	Application connector RAS-EC, see section: 12.2: "Connector 1P RAS-EC system"
3L	Application connector for accessories, see section: 12.4: "Connector 3L accessoires"
3P	Application connector for engine speed control, see section: 12.5: "Connector 3P ESC system"
23K	Application connector for body functions, see section: 12.12: "Connector 23K body functions"

(1) For pinning and wire numbers see the indicated sections.

Locations of application connectors

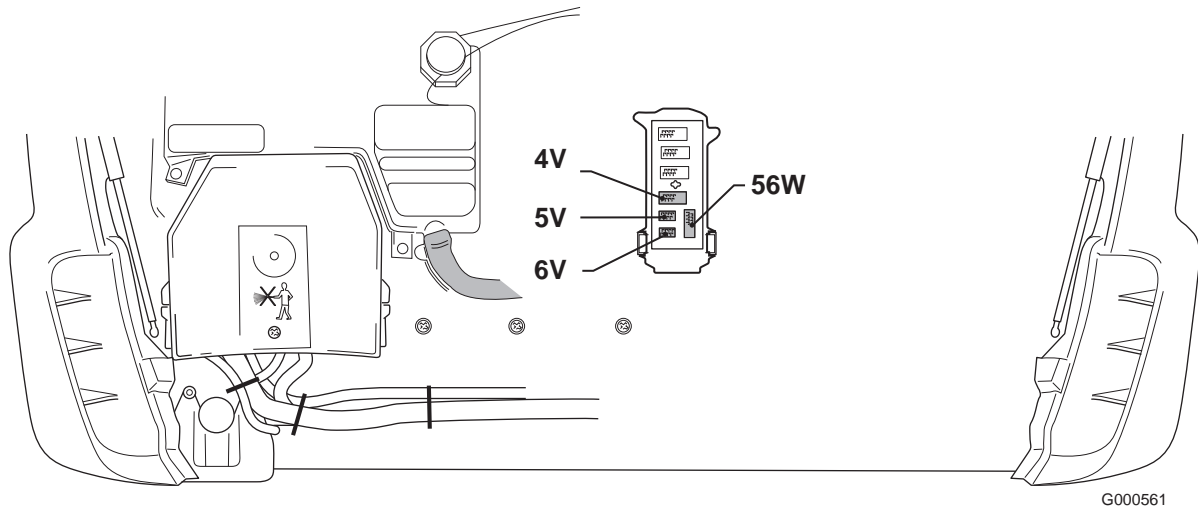

G000561

Connector Code	Descriptions ⁽¹⁾
4V	Application connector for refuse collector, see section: 12.8: "Connector 4V refuse collector"
5V	Application connector for refuse collector, see section: 12.9: "Connector 5V refuse collector"
6V	Application connector for refuse collector, see section: 12.10: "Connector 6V refuse collector"
56W	Application connector for refuse collector, see section: 12.14: "Connector 56W refuse collector"

(1) For pinning and wire numbers see the indicated sections.

9.3 LF AND CF65 SERIES CHASSIS CONNECTIONS

Location of application connectors

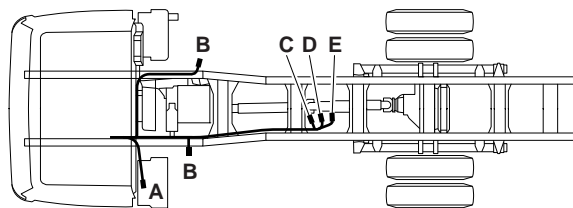

G000518

BODYBUILDERS' GUIDELINES

Electrical system LF series

Position	Connector Code	Description ⁽¹⁾
A	A070	Connector application superstructure; see section: 12.27: "Connector A070 accessories 8-pole)"
B		Connection for side markers
C	A103	Application connector for body function spare wires; see section: 12.35: "Connector A103 bodybuilder 12-pole"
D	A102	Application connector for body function; see section: 12.34: "Connector A102 body builder 8-pole"
E	A068	Application connector for engine speed control (12-pin); see section: 12.26: "Connector A068 (chassis - ESC system)"

(1) Check out the indicated sections for additional information on offered functionality, pinning and wire numbers within the connectors used.

Side marking lights

2-pole (location B in illustration)

At the position of the first side marker behind the cab, on both the left and right-hand side, a cable is located with a 2-pin connector. This connector contains wire numbers 2169 and 2170. Side markers and top lights can be connected from here (separate cables on the left and right hand chassis side), using the cable harnesses that are mentioned in chapter 13.6: "Electric cable contour lights chassis".



NOTE: If needed, director lamps on the cab mud guards can be repositioned to line up with the bodied chassis width by using the extension pieces as shown in chapter 13.7: "Extension piece for the LF mud guard".

**9.4 LF SERIES ACCESSORIES
CONNECTION HEADERSHELF**

Spare wiring headershelf

There is spare wiring from the bulkhead via the A-pillar to the headershelf.

The wiring (4 separate wires, no connector) runs from the headershelf to the bulkhead lead-through 1M (= grey 8 pole connector). The number of spare wires is 4. See chapter 12.1: "Connector 1M spare wiring" for the bulkhead connection details. See chapter 9.6: "LF series power supply" for the power supply connection details.

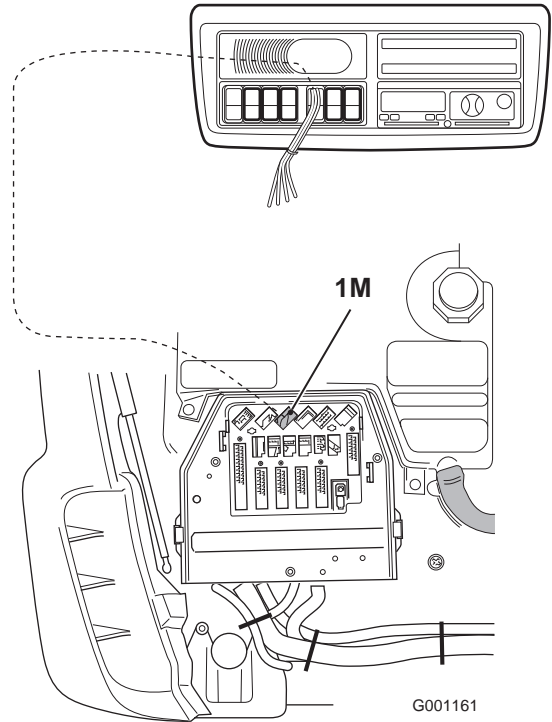

**9.5 LF SERIES ACCESSORIES
CONNECTION DASHBOARD**

**Spare wiring from dashboard area to
bulkhead lead-through**

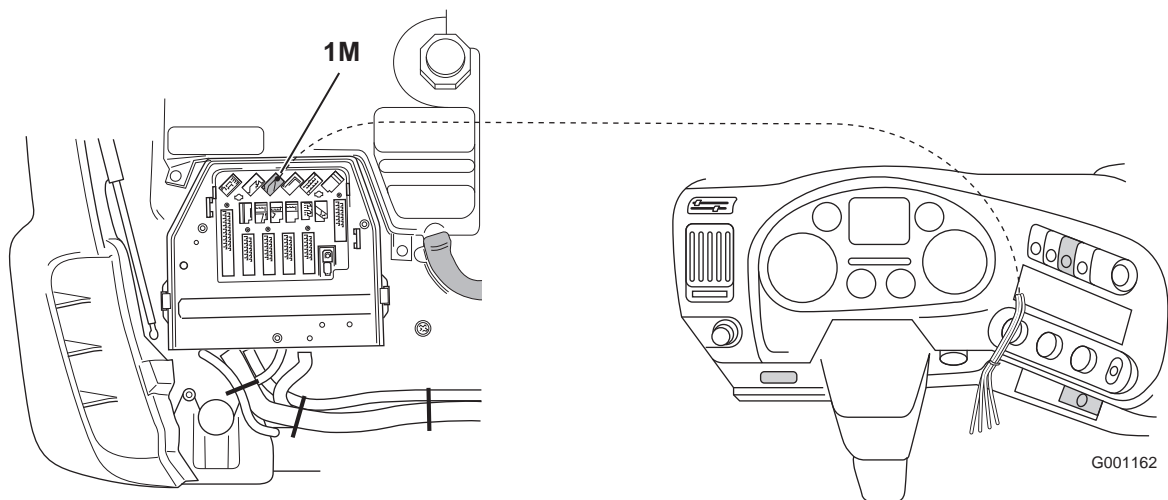

The wiring runs from a connector behind the radio compartment to the bulkhead lead-through 1M (= grey 8 pole connector). The number of spare wires is 4. See chapter 12.1: "Connector 1M spare wiring" for the bulkhead connection details.

BODYBUILDERS' GUIDELINES

Electrical system LF series

9.6 LF SERIES POWER SUPPLY

Power supply

Power supply - 24V/10A before and after contact are available in the bulkhead lead-through. See chapter 12.5: "Connector 3P ESC system" for details.



NOTE: Remember the total permissible power supply as listed in section 7.9: "Maximum load".

12V/15A accessory connection

A 24V/12V DC/DC- converter is used to provide a 12Volt for accessory systems. It is not allowed to use this 12V for driveline systems or driveline related systems. If a driveline (related) system needs 12V, it must be transformed from 24V into 12V inside the system itself for safety reasons. Connecting a 12V system via the DC/DC converter is only allowed for customer accessories.

12V/15A power supply is available for radio and telephone, and in the overhead console for CB and fax. Wire numbers: 1153 and M.



WARNING! The standard version 24/12V converter is 15A. The total current consumption from the 12V supply before and after contact for telephone, fax, radio and CB together (1 converter), must not exceed the specified value. Splitting of the 12V circuit using more than one converter is necessary if additional current consumption is required. Installing a heavier-duty converter is not recommended, in view of cable diameters and suppression. Location behind fuse PCB in central box.



NOTE: The result of this is that energy is continuously drawn from the batteries. Carry out this modification only if necessary.

9.7 LF SERIES RADIO PREPARATION

Radio preparation

For the radio connection, an ISO connector (connector code B365.A) has been fitted behind the radio panel, with 12V/ 10mA power supply before contact (wire 1153), power supply after contact (wire 1108: 12V/10A, switched via relay G377) and earth (M). Also, for the loudspeakers

(connector code B365.B), the wiring to the door, A-pillar (for tweeters) and rear wall (for loudspeakers) has been prepared as standard. If tweeters are installed, a dividing filter must be fitted.



WARNING! The standard version 24/12V converter is 15A. The total current consumption from the 12V supply before and after contact for telephone, fax, radio and CB together, must not exceed the specified value. Splitting of the 12V circuit using more than one converter is necessary if additional current consumption is required. Installing a heavier-duty converter is not recommended, in view of cable diameters and suppression.

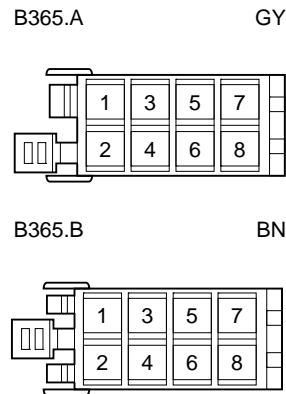
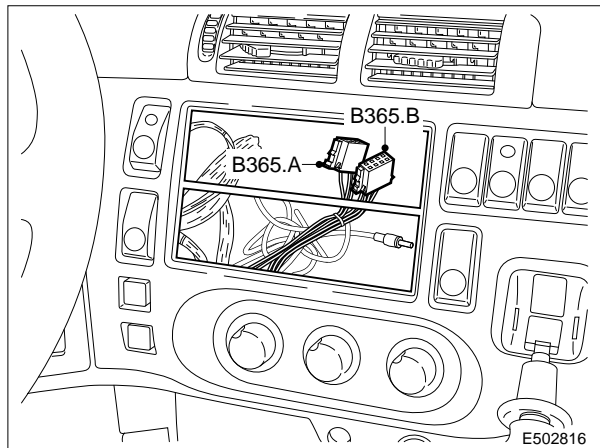

B365.A Power supply radio; see section: 12.49: "Connector D365.A - D365.B radio system"
 B365.B Loudspeakers radio

9.8 LF SERIES TELEPHONE PREPARATION

Telephone preparation

For a telephone connection, space has been reserved on the right-hand side of the radio panel, see position 1. The power supply to the telephone must be tapped from the 12V/10A accessory plug, see position 2.

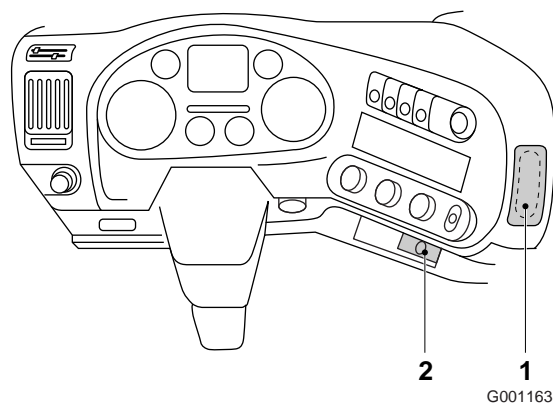

BODYBUILDERS' GUIDELINES

Electrical system LF series

9.9 LF SERIES ANTI-THEFT PROTECTION

LF series

If the vehicle is fitted with the standard anti-theft protection system, the body can be connected to the vehicle system via the application connector for accessories.

See section 9.3: "LF and CF65 series chassis connections".

Wire numbers 3659 and 3660 are both inputs, connected to **ground** via a switch. If interrupted, the alarm will sound. Wire 3651 is a 12 V supply coming from the alarm system, and meant for the power supply of the interior motion detection.



WARNING! For the latest details and versions, contact DAF.

9.10 LF SERIES ESC CONTROL

LF Series ESC control

Applicable selection codes:

0761: without engine speed control connector
0797: with engine speed control cab connector (3P)
9231: with engine speed control chassis connector (A068)



NOTE: Connector 3P is always present due to standardisation. If selco 0797 is selected, the corresponding functionality is also present (correct VIC software).

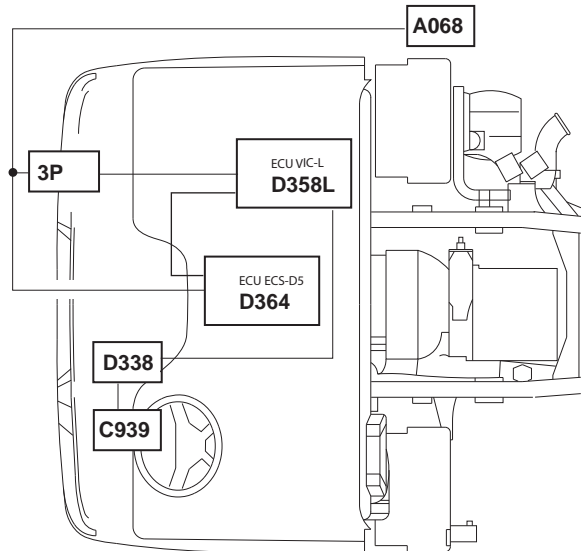

G001164

Applicable application connectors in cab and chassis depending on selection code:

Check out the sections indicated below for additional information on pinning and wire numbers within the connectors and ECU units used:

connector 3P: in section 12.5: "Connector 3P ESC system".

connector A068: in section 12.26: "Connector A068 (chassis - ESC system)".

Purpose of the function

The purpose of the engine speed control system is to enable the engine speed to be adjusted between idling speed and the maximum speed. This adjustable engine speed is used, among other things, to drive auxiliary consumers via a PTO. The engine speed control can be used while driving or when idling by setting the correct customer parameters using DAVIE. The engine speed control can be enabled by the driver using the steering wheel switches, if the correct selection codes have been chosen, through the superstructure equipment via the relevant application connector (A068 hardwired). Enabling the engine speed control via one of the application connectors takes priority over the steering wheel switches.

Schematic overview of ESC system control

The diagram below provides a schematic overview of the engine speed control. The two main groups for controlling the engine speed control can be identified as follows:

1. Enabling engine speed control by the driver via the VIC (Vehicle Intelligence Centre)
 - Steering wheel switches
2. Enabling engine speed control by the body via the VIC (Vehicle Intelligence Centre)
 - Cab application connector (3P connector)
 - Chassis application connector (A068 connector)

BODYBUILDERS' GUIDELINES

Electrical system LF series

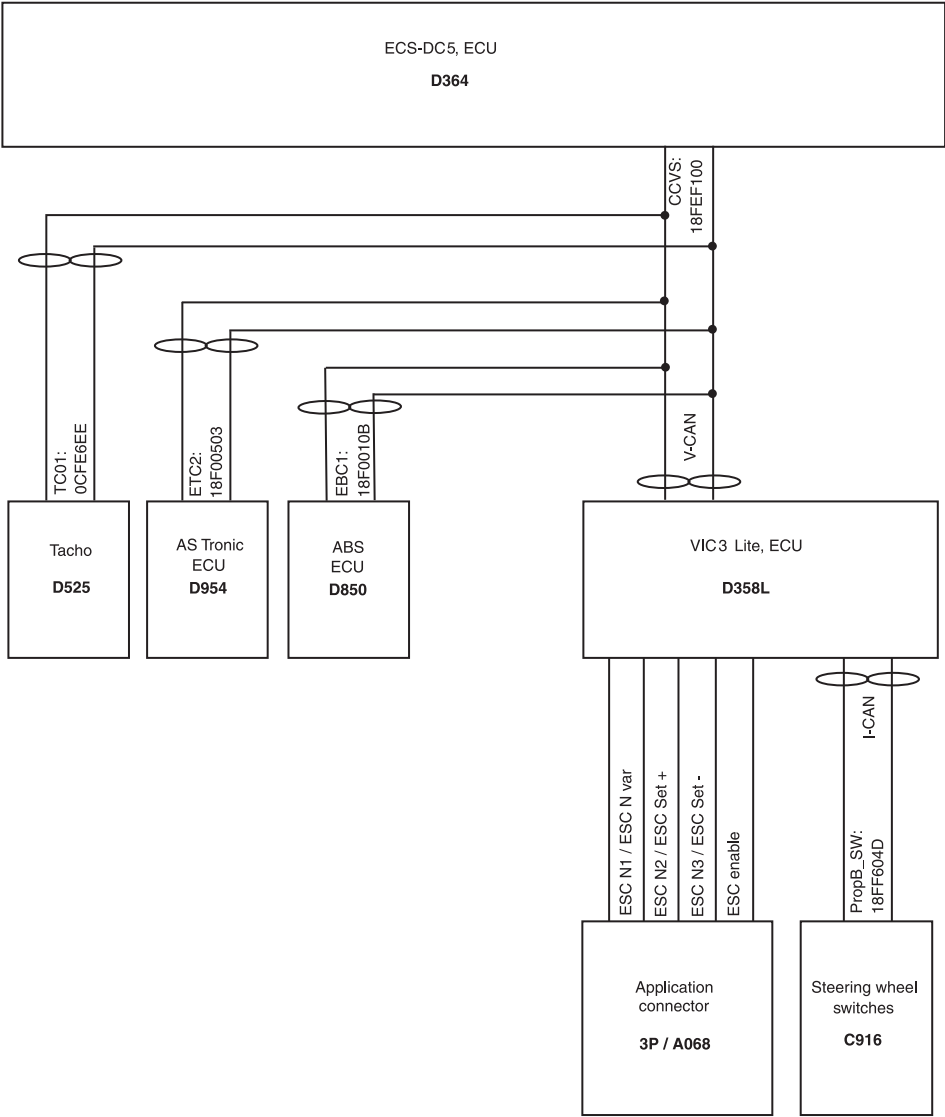

G001141

General ESC control system layout

9

CAN signal description				
CAN Message name	Message id	Used CAN Signals for ESC ⁽¹⁾	Startbit	Length
TC01	0CFE6CEE	Tachograph vehicle speed	48	16
PropB_SW	18FF604D	Cruise control resume switch	16	2
		Cruise control off switch	18	2
		Cruise control accelerate switch	20	2
		Cruise control coast switch	22	2
CCVS	18FEF100	Parking brake switch	2	2
		Cruise control active	24	2
		Cruise control enable switch	26	2
		Brake switch	28	2
		Clutch switch	30	2
		Cruise control set switch	32	2
		Cruise control coast switch	34	2
		Cruise control resume switch	36	2
		Cruise control accelerate switch	38	2
		Cruise control set speed	40	2
Cruise control state	53	2		
EBC1	18F0010B	EBS brake switch	6	2
ETC2	18F00503	Selected gear	0	8
PropA_BBM_to_Engine	18EF0025	tbd	tbd	tbd

(1) only ESC related messages are shown.

Enabling engine speed control by the driver

As is evident from the schematic overview, the VIC can receive the engine speed control signals from the steering wheel switches (via CAN). The VIC translates these signals into a CAN message, which is sent to the engine control unit.

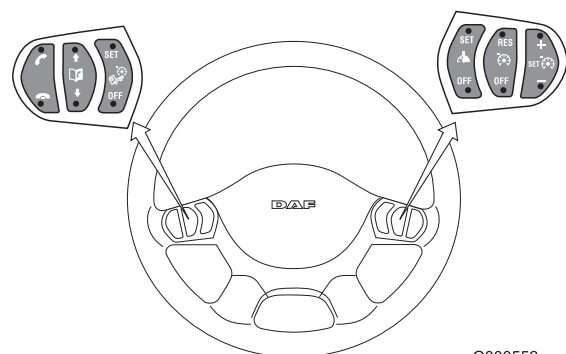

Steering wheel switches

G000552

BODYBUILDERS' GUIDELINES

Electrical system LF series

Operating functions of the steering wheel switches		
Function	Standard setting	Choices in ECS-DC5 (D358) via DAVIE (CP = customer parameter)
SET + SET -	Brief operating ⁽¹⁾ of "SET +" during engine speed control activates the set speed engine speed. The activation reacts on the falling edge of the signal.	CP 2-16
	Brief operation ⁽¹⁾ of "SET -" during engine speed control activates the resume speed engine speed. The activation reacts on the falling edge of the signal.	CP2-17
	Long operation ⁽²⁾ of "SET +" during engine speed control gives a continuous increase of the preset desired speed (default 250 rpm/s). This function can only be enabled after activation of the set speed once.	0<ramp<400 [rpm/s] CP2-22
	Long operation ⁽²⁾ of "SET -" during engine speed control gives a continuous decrease of the preset desired speed (default 250 rpm/s). This function can only be enabled after activation of the set speed once.	0<ramp<400 [rpm/s] CP2-22
	The desired engine speed can be varied using "set +/-" between minimum and the maximum speed to be set.	N_idling<speed limit<N_max (rpm) via CP2-15 and CP2-14
Res	Operating "Res" activates the engine speed control and sets the engine speed to the value entered using CP2-17 (default 1200 rpm). Activation by operating "Res" (resume) button twice. With this "Res" button the operation can toggle between N1 and N2..	To be set using CP2-17 between the values set using CP2-15 and CP2-14
OFF	Engine speed control is switched off using the "OFF" button.	

(1) Brief operation: touch time < 0.3 s.

(2) Long operation: touch time > 0.3 s.

9

Switch on and off conditions

To make engine speed control possible, a number of (default) cut-in conditions must be met, namely:

- The handbrake must be engaged. (CP2-32)
- The vehicle speed must not be faster than 10 km/h. (CP2-11)
- Clutch pedal is not operated. (CP2-34)
- Brake pedal is not operated. (CP2-33)
- Engine brake foot pedal is not operated. (no CP)

In addition, there are a number of faults that can be checked, which, if active, prevent the engine speed control from being activated.

- No faults are active that relate to vehicle speed.
- No faults are active that relate to Set+/Set-plausibility
- No faults are active that relate to engine speed.
- No faults are active that relate to CAN communication.

- No faults are active that relate to clutch signal plausibility.
- No faults are active that relate to handbrake signal.
- No faults are active that relate to clutch signal.
- No faults are active that relate to a neutral gearbox signal.

If, for the body function, it is necessary to deviate from the standard options tested and released by DAF, DAF shall no longer be responsible for the operation. The implementation of non-standard body functions and the possible consequences are the responsibility of the user (generally the bodybuilder), who then bears product liability.

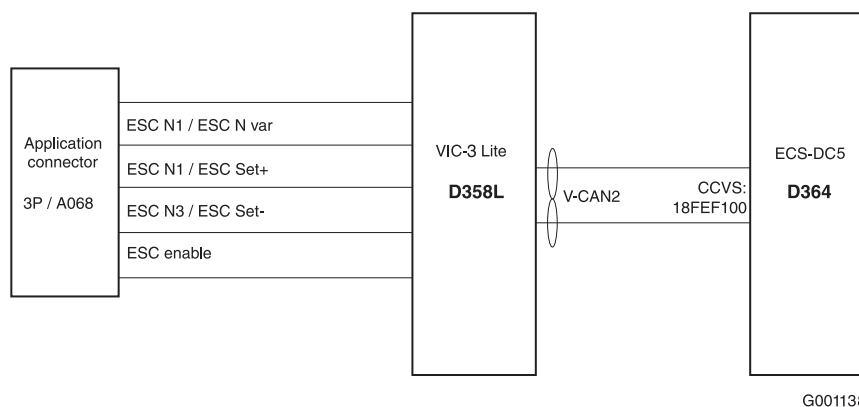

Schematic overview of ESC system control via the body

Hardwired activation of engine speed control

For operating the engine speed control through the body connection (see relevant selcos), the same functions, cut-in and cut-out conditions, and customer choices are offered as for the engine speed control through the steering wheel switch. Via the hardwired input on the application connector, two different engine speed control speed modes can be chosen via customer parameter 1-116. The two modes are:

1. Fixed speeds mode.
To activate these fixed speeds the engine speed control must first be enabled providing a high signal on pin A3 of cab connector 3P or pin 7 of the chassis connector A068. Then N1, N2 and N3 can be activated by providing a high signal on pins 8, 9 and 10 of chassis connector A068 or pin A4, A5 and A6 of connector 3P.
2. Variable engine speed control mode.
To activate the variable engine speed control mode first the enable pin A3 of the cabin connector or pin 7 of the chassis connector A068 must be activated. After that the Nvar enable pin on both connectors must be

BODYBUILDERS' GUIDELINES

Electrical system LF series

activated (pin A4/3P or pin 8/A068). Via the set+ or set- pins on both connectors a variable ESC will be possible. In the table on the next page all the different situations are described.



NOTE: For safety reasons it is **not** permitted to activate the "enable" via a through connection at the same time as N2, N3 or Nvar. If two separate connections are not used it will not be possible to switch off the engine speed control if a short circuit occurs.

Activation ESC fixed speeds via connector 3P or A068 (5 situations possible; functional description in next table)					
Function Connector / Pin	1	2	3	4	5
ESC enable Pin 3P/A3 or Pin A068/7	Oc	24V	24V	24V	24V
ESC_N1 Pin 3P/A4 or Pin A068/8	Dc	Oc	24V	Oc	Oc
ESC_N2 Pin 3P/A5 or Pin A068/9	Dc	Oc	Oc	24V	Oc
ESC_N3 Pin 3P/A6 or Pin A068/10	Dc	Oc	Oc	Oc	24V

(1) 24V only temporarily applied before start of engine. See situation 9 and 10 in next table for more details.

9

- Oc = open circuit
- Dc = don't care
- Sp = short pulse (brief operation: touch time with 24V < 0.3 s)
- Lp = long pulse (long operation: touch time with 24V > 0.3 s)

Situation	Engine Speed	CP ⁽¹⁾ in ECS-DC5 system	Default value	Remarks
1	N_engine = idle speed		700 rpm	Remote engine speed control disabled
2	N_engine = idle speed		700 rpm	Remote engine speed control enabled
3	N_engine = N1	2-27	900 rpm	Choice of throttle override available through customer parameter 2-30
4	N_engine = N2	2-28	1000 rpm	Choice of throttle override available through customer parameter 2-30
5	N_engine = N3	2-29	1100 rpm	Choice of throttle override available through customer parameter 2-30

(1) CP = Customer parameter.

Activation Variable Speed ESC speed via Application connector 3P or A068 (7 situations possible; functional description in next table)							
Function Connector / Pin	1	2	3	4	5	6	7
ESC enable Pin 3P/A3 or Pin A068/7	Oc	24V	24V	24V	24V	24V	24V
ESC_Nvar Pin 3P/A4 or Pin A068/8	Dc	Oc	24V	24V	24V	24V	24V
ESC_Set+ Pin 3P/A5 or Pin A068/9	Dc	Oc	Oc	Sp	Oc	LP	Oc
ESC_Set- Pin 3P/A6 or Pin A068/10	Dc	Oc	Oc	Oc	Sp	Oc	Lp

(1) 24V only temporarily applied before start of engine. See situation 9 and 10 in next table for more details.

- Oc = open circuit
- Dc = don't care
- Sp = short pulse (brief operation: touch time with 24V < 0.3 s)
- Lp = long pulse (long operation: touch time with 24V > 0.3 s)

BODYBUILDERS' GUIDELINES

Electrical system LF series

Situation	Engine Speed	CP ⁽¹⁾ in ECS-DC5 system	Default value	Remarks
1	N_engine = idle speed		700 rpm	Remote engine speed control disabled.
2	N_engine = idle speed		700 rpm	Variable remote engine speed control enabled.
3	N_engine = Nvar		900 rpm	Choice of throttle override available through customer parameter 2-30.
4	N_engine = current setting + 25rpm			"Bump-up" feature, Speed range available between Nidle en Nmax-esc parameter 2-14. If engine speed is not at current ESC setting (e.g. during throttle override) a short pulse on this connection will set the current ESC speed to the current engine speed.
5	N_engine = current setting - 25rpm			"Bump-down" feature, Speed range available between Nidle en Nmax-esc parameter 2-14. If engine speed is not at current ESC setting (e.g. during throttle override) a short pulse on this connection will set the current ESC speed to the current engine speed.
6	N_engine = current setting + 200rpm/sec			Ramp-up feature. Speed range available between Nidle and MAXESC speed'parameter.
7	N_engine = current setting - 200rpm			Ramp-up feature. Speed range available between Nidle and MAXESC speed'parameter.

(1) CP = Customer parameter.

Operating functions of the application connector (A068)		
Function ⁽¹⁾	Standard setting	Choice in ECS-DC5 via DAVIE (CP = customer parameter)
Enable ESC	If the engine speed control function is activated and the vehicle speed is lower than the limiting speed for engine speed control + 5 km/h, the engine speed control is enabled through the body connection. At the same time, operation via the steering column switch is blocked.	
SET + SET - Pulsing or continuous ⁽²⁾	Operating "SET+/-" switches the engine speed control on and sets the current engine speed as the desired speed (constant value).	
	Brief operation ⁽³⁾ of "SET +/-" during engine speed control gives a stepped increase or reduction of the engine speed (default 25 rpm).	0<step<400 [rpm] via CP2-20 and CP2-38
	Long operation ⁽⁴⁾ of "SET +/-" during engine speed control gives a continuous increase or reduction of the preset desired speed (default 200 rpm/s).	0<ramp<400 [rpm/s] via CP2-18 and 2-19
	When "SET+/-" is released, the current engine speed is set as the new desired engine speed	
	The desired engine speed can be varied using "SET +/-" between the minimum and the maximum speed to be set.	N_idling<speed limit<Nmax (0 rpm) via CP2-15 and CP2-14
N_variable	Operating "Enable N_variable" activates the engine speed control and sets the last desired engine speed set using SET+ and SET-. This value is also memorised when the ignition is switched off. Varying the desired speed is possible using SET+/- but only if the input "Enable N_variable" is activated.	
N_2	Operating "N2" activates the engine speed control and sets the engine speed to the value entered using CP2-16 (default 800 rpm).	To be set using CP2-28 between the values set using CP2-15 and CP2-14
N_3	Operating "N3" activates the engine speed control and sets the engine speed to the value entered using CP2-17 (default 1200 rpm).	To be set using CP2-29 between the values set using CP2-15 and CP2-14
V_max application ⁽⁵⁾	If the Vmax application input is activated by providing a 24 V signal, the vehicle speed is limited to the pre-programmed value (default 30 km/h).	Adjustable using CP2-10 between a value of 0 and 30 km/h
Engine speed	Output signal, square-wave, 30 pulses per revolution; LS pulse	

- (1) If operated simultaneously, the priority is as follows (high to low): "enable ESC", "N2", "N3", N_variable (SET+/-).
 (2) Pulse signal = a signal becomes a pulse when the rising edge reaches a value of 0.6 x U_{bat}. Continuous signal is "high" at a voltage level of 0.6 x U_{bat} and "low" if below a level of 0.4 x U_{bat}.
 (3) Brief operation: touch time < 0.3 s (default).
 (4) Long operation: touch time > 0.3 s (default).
 (5) Special applications (e.g. refuse vehicles).

BODYBUILDERS' GUIDELINES

Electrical system LF series

In addition to various cut-in conditions, the cut-out conditions must also be taken into account. These cut-out conditions are:

- The handbrake must be disengaged. (CP2-32)
- The vehicle speed is higher than limit value + offset (10+5=15 km/h). (CP2-11)
- Clutch pedal is operated. (CP2-34)
- Brake pedal is operated. (CP2-33)
- Engine brake foot pedal is operated. (no CP)
- Retarder is operated. (no CP)

In addition, there are a number of faults that are checked and if active, the engine speed control should be switched off:

- A vehicle speed fault is active.
- A plausibility fault is active on the set+/set-switches.
- An engine speed fault is active.
- A fault that relates to the CAN communication is active.
- A plausibility fault is active that relates to the clutch signal.
- A fault is active that relates to the handbrake signal.
- A fault is active that relates to the clutch signal.
- A fault is active that relates to the neutral signal of the gearbox.

In addition to the cut-in and cut-out conditions, the system also has a number of overrule conditions. An overrule condition means that the control under which the system is operating at that point is temporarily suppressed. These overrule conditions are:

- Accelerator pedal operation. (CP 2-30)
The accelerator pedal can be used to temporarily increase the engine speed up to a maximum value preset under customer parameter 2.14 (max. ESC speed).
- Exceeding vehicle speed limit. (CP 2-11)
- ASR activation.
- Speed limiter activation.

BODYBUILDERS' GUIDELINES

Electrical system LF series

Customer ⁽¹⁾ parameter ID	Customer parameter name	System	Value
	ENGINE SPEED CONTROL		
1-28	ESC Brake enable	VIC-3L	ACTIVE / NOT ACTIVE
1-29	ESC Clutch enable	VIC-3L	ACTIVE / NOT ACTIVE
1-30	ESC Parkbrake enable	VIC-3L	ACTIVE / NOT ACTIVE
1-116	ESC Speed mode	VIC-3L	VARIABLE SPEED / 3 FIXED SPEEDS

(1) For changing default parameter settings see chapter 7.19: "Guideline for the Customer Parameter Change Form"

Customer ⁽¹⁾ parameter ID	Customer parameter name	System	Value
	ENGINE SPEED CONTROL		
2-14	MAX ESC SPEED	ECS-DC5	Rpm
2-15	MIN ESC SPEED	ECS-DC5	Rpm
2-16	SET SWITCH ESC-SPEED	ECS-DC5	Rpm
2-17	RESUME SWITCH ESC-SPEED	ECS-DC5	Rpm
2-21	MAX ENGINE LOAD ESC	ECS-DC5	Nm
2-22	ACCELERATE / DECELERATE ESC	ECS-DC5	Rpm/s
2-27	ESC CHANGE APPLICATION CONN. N1	ECS-DC5	Rpm
2-28	ESC CHANGE APPLICATION CONN. N2	ECS-DC5	Rpm
2-29	ESC CHANGE APPLICATION CONN. N3	ECS-DC5	Rpm

(1) For changing default parameter settings see chapter 7.19: "Guideline for the Customer Parameter Change Form"

Customer ⁽¹⁾ parameter ID	Customer parameter name	System	Value
	ENGINE SPEED CONTROL CONDITIONS		
2-30	ACCEL. PEDAL	ECS-DC5	ACTIVE / NOT ACTIVE
2-31	MAX RPM ACCELERATOR PEDAL	ECS-DC5	Rpm
2-32	PARK BRAKE	ECS-DC5	ACTIVE / NOT ACTIVE
2-33	BRAKE	ECS-DC5	ACTIVE / NOT ACTIVE
2-34	CLUTCH	ECS-DC5	ACTIVE / NOT ACTIVE

(1) For changing default parameter settings see chapter 7.19: "Guideline for the Customer Parameter Change Form"

BODYBUILDERS' GUIDELINES

Electrical system LF series

9.11 LF SERIES PTO CONTROL / PROTECTION

LF45 - LF55 Series PTO-control

Applicable selection codes:

Selco codes	description
4610	without engine PTO
9181	with engine PTO / without control

Selco codes	description
1412	without gearbox PTO-1 / without control
1118	with gearbox PTO-1 / without control
various	with gearbox PTO / with control

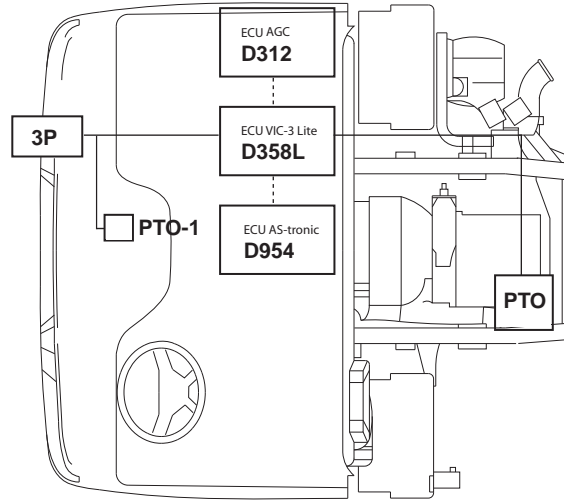

G001203

Applicable application connectors in cab and chassis depending on selection code:

Connector Codes	See the sections indicated below for additional information on pinning and wire numbers in the connectors used.
3P	section: 12.5: "Connector 3P ESC system"

Purpose of the function

A PTO (power take off) enables a body builder or customer to derive mechanical energy from the vehicle to activate special functions, e.g. pumps. A PTO can be switched on by activating an EP valve. The driver can request activation of the PTO by activating the PTO switch. Before activating the PTO the VIC3L will check if the switch-on conditions are met. Also the PTO will be disabled if, with an activated PTO, one of the switch-off conditions are met. The switch on and off conditions can be adjusted by the DAF dealer via DAVIE. For the LF series, only one PTO control has been prepared.

The main purpose of the PTO control system is to engage the PTO under safe conditions. The PTO can be used while driving or when idling by setting the correct customer parameters using DAVIE.

Schematic overview of PTO control

The diagram below provides a schematic overview of the PTO control. The two main groups for controlling the PTO can be identified as follows:

1. Enabling PTO control by the driver via the dashboard switches.
2. Enabling PTO control by the body via hardware connector 3P.
 - Cab application connector (hard wired)
 - Chassis application connector (CAN controlled)

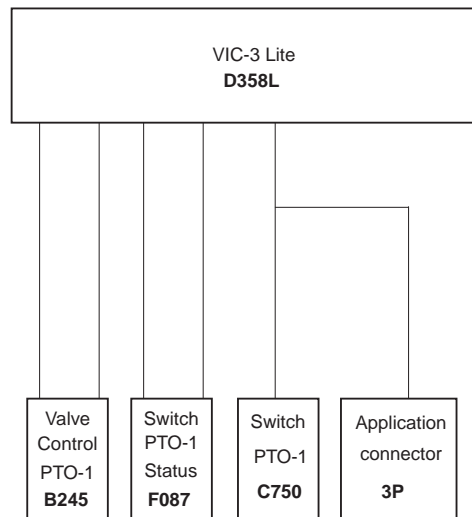

G001202

General PTO control system layout

Engine PTO

For vehicles with a GR engine a special engine PTO can be used. This 12 o'clock GR engine PTO cannot be switched on and off.

Gearbox PTO (manual gearbox)

By using the switch on position 7 (see section 9.1: "LF series cab switch and connector locations"), the VIC (Vehicle Intelligence Centre) is activated via wire 4594 (active earth). The VIC checks on the basis of the cut-in conditions whether the output (wire 4596) may be activated. These conditions must be met within a specified control time (default = 4 sec.). If this is not the case, an error message will appear on the DIP (display on instrument panel). The PTO output will not be switched on, even if following the expiry of the control time, the cut-in conditions are met. To allow the PTO to be switched on, the switch must first be set to off, and then switched back on.

If activation of the PTO is permitted, wire 4596 is activated, and the VIC expects a return status message from the PTO system, within a second control time. An immediate check will also be carried out as to whether the cut-out conditions are met, or not. If the return status message does not arrive on time, or if the message states that the cut-out conditions are met, the output will be switched off, and the PTO warning will once

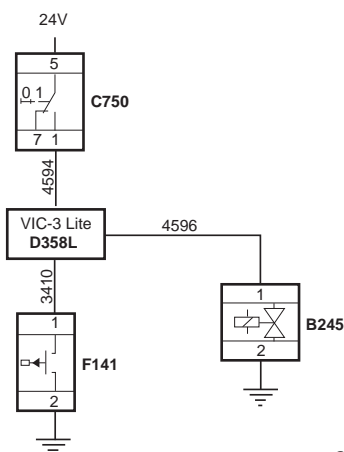

G001206

BODYBUILDERS' GUIDELINES

Electrical system LF series

again appear on the DIP. The 'PTO active' indication on the DIP will not illuminate, until the return status message is concluded successfully. If this indication lights up, the PTO-1 hour counter will start to run (installed in the DIP menu). Control wire 4594 (active +24V, in the cab this wire has number 3420) is included in the ESC application connector, which means that preparation for operating the PTO (switching it on and keeping it running) from the body is provided.

Gearbox PTO (Automatic gearbox)

In general the PTO operation (including the interlocks) in combination with automatic gearboxes is identical to the manual gearbox PTO operation, with the following exception;

After switching the PTO on and complying with the interlocks programmed, the E/P valve output (2) of the BBM is activated. This signal is used by the automatic gearbox control unit (AGC-A4) as a request for activating the gearbox PTO. The automatic gearbox control unit checks its internal parametring (see chapter 7.15: "Automated and automatic gearboxes") whether the PTO can be switched on.

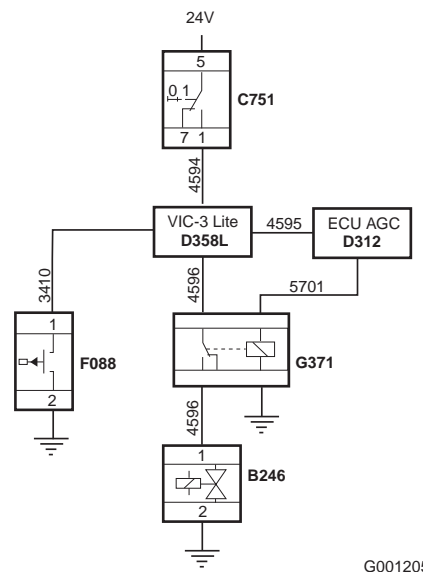

G001205

Gearbox PTO (Automated gearbox)

DAF introduced an automated gearbox called AS-Tronic. This is a mechanical gearbox, which is operated via an electronic control unit. This means that some of the driver's tasks are monitored or taken over.

The PTO which is fitted to this gearbox, therefore has a control/protection system that is different from that used in combination with the manually operated gearboxes.

There is a choice between two settings of the PTO interlocks:

- operation of PTO on a stationary vehicle
- operation of PTO on a moving vehicle

Operation of PTO on a stationary vehicle is always the basic setting

Cut-in conditions:

- The handbrake must be active
- The engine is running
- The gearbox must be in neutral
- The engine speed is lower than Nmax cut-in (650 rpm)
- The vehicle speed is lower than 1.5 km/h

Cut-out conditions:

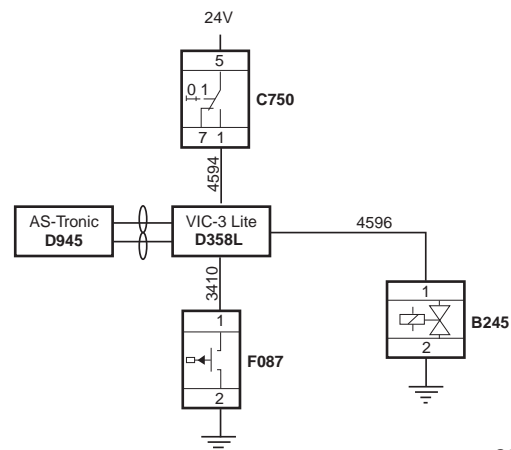

G001204

- The handbrake must be de-activated
- The engine is not running
- The vehicle contact is switched off
- The vehicle speed is higher than 1.5 km/h

Gear-shift commands are not carried out during PTO operation.

Operation of PTO on a moving vehicle should be activated using the diagnostic tool (DAVIE XD)

Cut-in conditions:

- The handbrake must be active
- The engine is running
- The gearbox must be in neutral
- The engine speed is lower than Nmax cut-in (650 rpm)
- The vehicle speed is lower than 1.5 km/h

Cut-out conditions:

- The engine is not running
- The vehicle contact is switched off

Changing gear during driving is not possible. So when driving off, the gear eventually required during driving should already be engaged!

Note:

AS-Tronic software version limits instationary PTO use, to 1st and RL gear. No gearchange is possible in this version. Check the vehicle configuration on this in case instationary PTO use is required.

Depending on the situation, the PTO warning is given between 2 and 5 seconds after a defect or undesirable situation occurs.

Customer parameter list

In the next tables all related customer parameters are listed.

BODYBUILDERS' GUIDELINES

Electrical system LF series

Customer ⁽¹⁾ parameter ID	Customer parameter name	System	Value
	PTO-1 switch on conditions		
1-01	PTO 1 ON - brake valid	VIC-3L	ACTIVE / NOT ACTIVE
1-02	PTO 1 ON - brake use	VIC-3L	PRESSED / RELEASED
1-03	PTO 1 ON - clutch valid	VIC-3L	ACTIVE / NOT ACTIVE
1-04	PTO 1 ON - clutch use	VIC-3L	PRESSED / RELEASED
1-05	PTO 1 ON - park brake valid	VIC-3L	ACTIVE / NOT ACTIVE
1-06	PTO 1 ON - park brake use	VIC-3L	APPLIED / RELEASED
1-07	PTO 1 ON - engine running valid	VIC-3L	ACTIVE / NOT ACTIVE
1-08	PTO 1 ON - engine running use	VIC-3L	RUNNING / NOT RUNNING
1-09	PTO 1 ON - maximum engine speed	VIC-3L	Rpm
1-10	PTO 1 ON - maximum vehicle speed	VIC-3L	km/h

(1) For changing default parameter settings see chapter 7.19: "Guideline for the Customer Parameter Change Form"

Customer ⁽¹⁾ parameter ID	Customer parameter name	System	Value
	PTO-1 switch off conditions		
1-12	PTO 1 OFF - brake valid	VIC-3L	ACTIVE / NOT ACTIVE
1-13	PTO 1 OFF - brake use	VIC-3L	PRESSED / RELEASED
1-14	PTO 1 OFF - clutch valid	VIC-3L	ACTIVE / NOT ACTIVE
1-15	PTO 1 OFF - clutch use	VIC-3L	PRESSED / RELEASED
1-16	PTO 1 OFF - park brake valid	VIC-3L	ACTIVE / NOT ACTIVE
1-17	PTO 1 OFF - park brake use	VIC-3L	APPLIED / RELEASED
1-18	PTO 1 OFF - engine running valid	VIC-3L	ACTIVE / NOT ACTIVE
1-19	PTO 1 OFF - engine running use	VIC-3L	RUNNING / NOT RUNNING
1-20	PTO 1 OFF - maximum engine speed	VIC-3L	Rpm
1-21	PTO 1 OFF - maximum vehicle speed	VIC-3L	km/h

(1) For changing default parameter settings see chapter 7.19: "Guideline for the Customer Parameter Change Form"

Customer ⁽¹⁾ parameter ID	Customer parameter name	System	Value
	PTO-1 Other		
1-31	PTO 1 Type	VIC-3L	STATIONAIRY / INSTATIONAIRY / ENGINE
1-34	PTO 1 ON Timeout	VIC-3L	Milliseconds
1-35	PTO 1 OFF Timeout	VIC-3L	Milliseconds

(1) For changing default parameter settings see chapter 7.19: "Guideline for the Customer Parameter Change Form"

9.12 LF SERIES FMS SYSTEM

LF series FMS system

Applicable selection codes:

8360: without Fleet Management System

6407: with Fleet Management System preparation

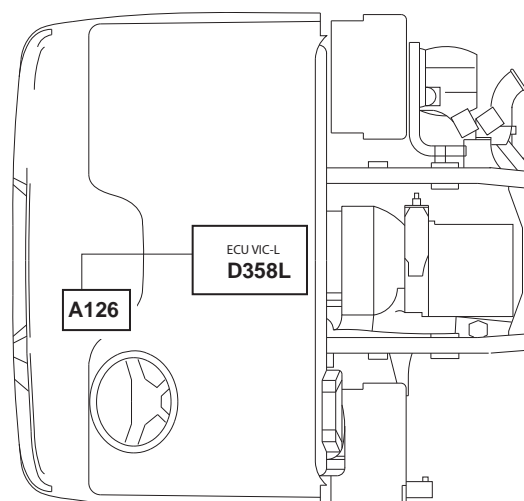

Applicable FMS application connectors cabine:

Check out the sections indicated below for additional information on pinning and wire numbers within the connectors and ECU units used:

connector A126: in section 12.44: "Connector A126 FMS 2-pole".

Purpose of the function

FMS stands for **F**leet **M**anagement **S**ystem and is used to provide information about condition of the vehicle to the fleet owner for logistic purposes. The (wireless) transmission of the data from vehicle to user is performed by a third party ECU which will get the data provided by the VIC-3 via de D-CAN interface.

BODYBUILDERS' GUIDELINES

Electrical system LF series

The main vehicle manufacturers, including DAF, have together agreed on the data to be universally provided for these FMS systems via the CAN link. Third parties are able to connect and to get the data from the truck CAN bus system. This document describes which D-CAN messages will be supported via the FMS prepared selco 6407.

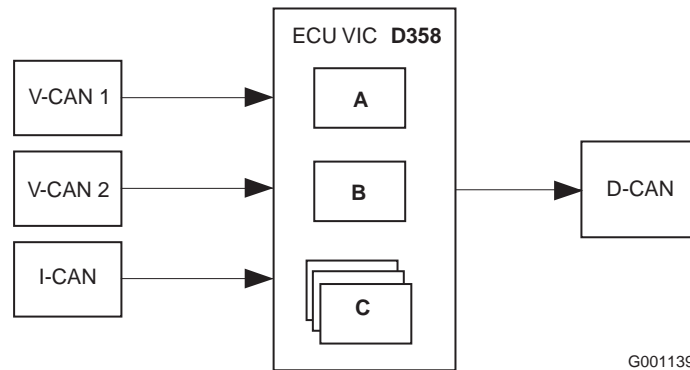

G001139

- A D-CAN gateway for FMS standard messages
- B D-CAN gateway for additional DTS messages (for future use)
- C PLC functions

From week 2008-13 a new two pole-connector is available for connecting to the D-CAN bus where the FMS messages will be broadcasted.

A Fleet Management System needs some specific information to know which CAN-data is available and how to handle this CAN-data. This information is sent in the CAN-message "FMS standard software version supported". This CAN-message is accepted by SAE J1939. Before there was no standard CAN-message and DAF would send the CAN-message "FMS standard information".

The following table describes the amount of data which will be sent by DAF on the D-CAN for FMS preparation.

BODYBUILDERS' GUIDELINES

Electrical system LF series

Message	Message ID ⁽²⁾	Repetition Rate (ms)	FMS Prepared Selco 6407
EEC2	0C F0 03 00	50	X
EEC1	0C F0 04 00	20	X
Engine hours revolution	18 FE E5 00	On request	X
Vehicle Identification	18 FE EC EE	On request	X
High Resolution Vehicle Distance	18 FE C1 EE	1000	X
TC01	0C FE 6C EE	50	X
Engine temperature	18 FE EE 00	1000	X
Fuel economy	18 FE F2 00	100	X
Service	18 FE C0 27	1000	X
Vehicle weight	18 FE EA 27	1000	X
Dash display	18 FE FC 27	1000	X
FMS standard interface	1C FD D1 27	10000	X
CCVS	18 FE F1 00	100	X
Fuel consumption	18 FE E9 00	1000	X
DM1	18 FE CA XX	1000 ⁽¹⁾	X
TP_DT (BAM)	1C EB FF XX	-	X
TP_CM	1C EC FF XX	-	X
DM1 VIC	18 FE CA 27	1000	X
TP_DT (BAM)	1C EB FF XX	-	X
TP_CM	1C EC FF XX	-	X
PropB_BBM	18 FF 82 25	250	X
ERC1_XR	18 F0 00 29	100	X
ERC1_DR	18 F0 00 10	100	X
EBC1	18 F0 01 0B	100	X
Tire condition (truck)	18 FE F4 33	500	X
Tire condition (trailer)	18 FE F4 C8	500	X
EBS23	18 FE C6 C8	100	X
RGE23	18 FE 5E C8	1000	X
EBS22	18 FE C4 C8	100	X
RGE22	18 FE 5C C8	100	X
Ambient conditions	18 FE F5 00	1000	X
Inlet / exhaust conditions	18 FE F6 00	500	X
Engine fluid level pressure	18 FE EF 00	500	X
Time date	18 FE E6 EE	1000	X
PropB_EST42	18 FF 40 10	100	X
Tank information #1	18 FE 56 3D	1000	X
Driver information	18 FE 6B EE	On request	X
Combination vehicle weight	18 FE 70 0B	On request	X
ETC2	18 F0 05 03	100	X

BODYBUILDERS' GUIDELINES

Electrical system LF series

Message	Message ID ⁽²⁾	Repetition Rate (ms)	FMS Prepared Selco 6407
Operator wiper and washer controls	18 FD CD 27	100	X
Operator external Light controls	18 FD CC 27	100	X
Cab illumination	18 D0 FF 27	5000	X
Vehicle hours	18 FE EC 27	1000	X

(1) Repetition rate when DM1 is active.

(2) For detailed message content see equivalent document "FMS CAN message overview.pdf" on the information sheet web page. (The Internet URL for the corporate DAF website is: www.daf.com -> follow the main menu item: "Products" -> Bodybuilder guidelines webpage -> Information Sheet webpage)

9.13 REFUSE PREPARATION LF SERIES

Applicable application connectors in cab and chassis depending on selection code:

9107: 30 +85km

9240: Application connector refuse collector



NOTE: Connector 3P is always present due to standardisation.

For part numbers of the bulkhead connectors check chapter 9.2: "LF series bulkhead connections".

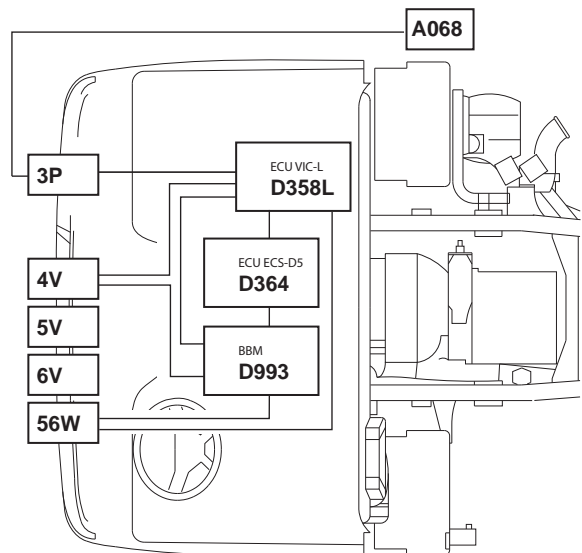

G001218-1

Connector location Codes ⁽²⁾	Description ⁽¹⁾
3P	Engine Speed Control, see section: 12.5: "Connector 3P ESC system"
4V	Refuse Collector, see section: 12.8: "Connector 4V refuse collector"
5V	Refuse Collector, see section: 12.9: "Connector 5V refuse collector"
6V	Refuse Collector, see section: 12.10: "Connector 6V refuse collector"
56W	Refuse Collector, see section: 12.14: "Connector 56W refuse collector"

(1) For pinning and wire numbers see the indicated sections.

(2) The here mentioned connector location codes sometimes are identical with the connector code of the actual plugged in connector.

The LF series can be specified with Selco 9240, which will offer 4 connectors in the narrow sized bulkhead lead through located in the middle of the cab front panel. Signal processing is carried out in a BBM (Body Builder Module) application.

A refuse preparation enables a body builder to activate special refuse functionality such as:

1. Stop&Go
 2. Body Release
 3. Body Active
 4. High rpm Request
 5. Vehicle speed limitation with operated footboard
 6. Remote engine start
 7. Remote engine stop
 8. Brake control
 9. Speed Switches
1. Stop&Go
This function automates the process of shifting from drive to neutral at vehicle standstill and shifting from neutral to drive when driving off without the driver manually have to operate the gear shift selector. The Stop&Go function can be activated and deactivated by the driver by operating the toggle switch. When this function is active, the superstructure of a refuse truck can set a high idle speed or customer to derive mechanical energy from the vehicle to activate special functions, e.g. pumps. A PTO can be switched on by activating an EP valve. The driver can request activation of the PTO by activating a PTO switch. Before activating the PTO the BBM will check if the switch-on conditions are met. Also the PTO will be disabled if, with an activated PTO, one of the switch-off conditions are met. The switch on and off conditions can be adjusted by the DAF dealer via DAVIE. Up to two PTO's can be controlled by the Body Builder Module.
 2. Body Release.
This function can be used to provide the body builder with the information that the vehicle is in a secure state of operation. The body builder can use this signal to safely operate/control the superstructure. It is possible to configure the reset conditions for body release by adjustin the customer parameters.
 3. Body Active.
This function is a safety function and will enable or disable the outputs to the function body release and high rpm request depending on the input status body active. If the body active input is enabled both seperate outputs will be set for activation.

BODYBUILDERS' GUIDELINES

Electrical system LF series

The outputs will be enabled if the related input for this output (high rpm request and body release) are active. These outputs will be disabled if the enable condition aren't met anymore.

4. High rpm request.
This function is to set a predefined engine speed when a high engine speed is requested by the superstructure. The requested engine speed will only be set if the switch on conditions are met. This enables the superstructure of a refuse truck to set a high idle engine speed N3 in neutral gear position at vehicle standstill. The superstructure can request this high idle engine speed to drive a hydro pump to perform a press cycle. When the autoneutral request is released, engine speed N2 (reduced high idle speed) is set and the engine speed drops in order to enable the Allison gearbox to shift from neutral to drive (Stop&Go functionality) and to limit clutch wear with manual gearboxes.
5. Vehicle speed limitation with active footboard.
In this function the Vmax application input or application speed limiter input from a body builder CAN message is used to set the signal application speed limiter in a CAN message to the engine ECU. The function can be used by the body builder e.g. limiting speed if a person is on the footboard of a garbage truck. The speed limit value can be adjusted by a customer parameter.
6. Body Release.
This function can be used to provide the body builder with the information that the vehicle is in a secure state of operation. The body builder can use this signal to safely operate/control the superstructure. It is possible to configure the reset conditions for body release by adjusting the customer parameters.
7. Remote engine start.
In the function Remote Engine Start the Remote Engine Start input from the engine application connector or the engine start signal from a CAN message or the internal engine start (start/stop) signal is used to control the Remote Engine Start output. This output is directly connected to the starter engine relay. The body builder can use this function to start the engine from outside the cabin. This function can be used to provide the body builder with the information that the vehicle is in a secure state of operation. The body builder can use this signal to safely operate/control the superstructure. It is possible to configure the reset conditions for body release by adjusting the customer parameters.

8. Remote engine stop.
In the function Remote Engine Stop the Remote Engine Stop input from the engine application connector or internal Start/Stop or Engine Stop from a Body builder CAN message is used to set the signal Engine Stop in a CAN message to the Engine ECU. This function can be used by the body builder to connect an stop button.
9. Brake Control.
If somebody is standing on the footboard of a refuse truck, reversing of the vehicle shall be made impossible. For refuse trucks the parking brake must and engine stop can be activated when reverse gear is selected while the refuse step switch (Vmax application) is active. The parking brake must be kept active untill KL15 is switched off. For safety reasons, this functions can only be activated if the vehicle speed is below a predefined speed (default 30km/h) To activate the parking brake the BBM activates a 3/2 electro pneumatic valve (via a relay) which depressurizes the spring brakes. To activate the engine stop, the BBM sends a CAN message to the engine.
10. Speed switches.
This function is to provide three information signals to the body builder; two for indicating that the vehicle speed is above a predefined speed (5km/h or 10km/h) and one for indicating that the engine speed is above a predefined value (1400rpm)

Customer parameter list in BBM unit

Customer Parameter ID	Customer Parameter Name	Value (Recommended)
	PTO status out	
1-94	PTO input	NO PTO PTO 1 status PTO 2 status PTO 1 and 2 status

(1) For changing default parameter settings see chapter 7.19: "Guideline for the Customer Parameter Change Form".

	Body Release Refuse	
1-99	Body release	DEACTIVATED
1-101	Driveline engaged	NOT ACTIVE
1-102	Maximum engine speed	Rpm
1-103	Park Brake	APPLIED / RELEASED
1-104	Maximum vehicle speed	Km/h

	Engine running	
1-105	Engine running	ENABLED

BODYBUILDERS' GUIDELINES

Electrical system LF series

Remote engine start/stop parameters		
1-86	Engine start enable	ENABLED
1-87	Engine stop maximum speed	0 km/h

Speed switches		
1-95	RPM switch	1400 Rpm
1-96	Vehicle speed switch 1	5 km/h
1-97	Vehicle speed switch 2	10 Km/h

Stop & Go Allison		
1-127	External auto neutral request	DISABLED

CVSG (Gauges)		
1-120	Coolant temperature	DISABLED
1-121	Oil pressure	DISABLED
1-122	Oil temperature	DISABLED
1-123	Fuel level	DISABLED
1-124	Transmission oil temperature	DISABLED
1-125	Air pressure circuit 1	DISABLED
1-126	Air pressure circuit 2	DISABLED

Fault detection Vmax Application pin C17		
1-128	Fault detection pin C17	Open circuit / Short circuit ground

Customer parameter list in ECS-DC5 unit

Customer Parameter ID	Customer Parameter Name	Value (Recommended)
LIMITERS		
2-10	Vmax APPLICATION SPEED	30 Km/h
2-11	vmax ESC	30 Km/h
2-12	MAX. CRUISE CONTROL SPEED	85 Km/h

(1) For changing default parameter settings see chapter 7.19: "Guideline for the Customer Parameter Change Form".

ENGINE SPEED CONTROL		
2-14	MAX. ESC-SPEED	1500 Rpm
2-15	MIN. ESC-SPEED	600 Rpm
2-18	ACCELERATION RAMP CONTINUOUS UP ESC	200 Rpm/s
2-19	ACCELERATION RAMP CONTINUOUS DOWN ESC	200 Rpm/s
2-20	ACCELERATE UP PER TIP	25 Rpm/tip
2-38	DEACCELERATE DOWN PER TIP	25 Rpm/tip

	ENGINE SPEED CONTROL	
2-22	ACCELERATE FROM IDLE TO TARGET SPEED IN ESC	1000 Rpm/s
2-16	ESC CAB N1	600 Rpm
2-17	ESC CAB N2	600 Rpm
2-28	ESC CHANGE APPLICATION CONN. N2	850 Rpm
2-29	ESC CHANGE APPLICATION CONN. N3	1100 Rpm

	ENGINE SPEED CONTROL CONDITIONS	
2-30	ACCEL. PEDAL	ACTIVE
2-31	MAX. RPM ACCEL. PEDAL	1500 Rpm
2-32	PARK BRAKE	NOT ACTIVE
2-33	BRAKE	NOT ACTIVE

9.14 LF SERIES TRAILER CONNECTION POINTS

Vehicle models for drawbar applications always have a 24V electric trailer connection. The electric trailer connection consists of three 7-pin sockets:

- Standard Lighting connector A000; see section 12.18: "Connector A000 trailer system (ISO1185 type 24N)"
- Accessories connector A001; see section 12.19: "Connector A001 trailer system (ISO3731 type 24S)"
- ABS/EBS connector A004; see section 12.20: "Connector A004 trailer system (ISO7638)"

BODYBUILDERS' GUIDELINES

Electrical system LF series

ELECTRICAL SYSTEM CF SERIES

	Page	Date
10.1 CF series cab switch and connector locations.	269	201019
10.2 CF series bulkhead connection overview	270	201019
10.3 CF75 and CF85 series chassis connections	272	201019
10.4 CF series accessories connections	273	201019
10.5 CF series accessories connection in dashboard	274	201019
10.6 CF series power supply	274	201019
10.7 CF series radio preparation	275	201019
10.8 CF series CB preparation	277	201019
10.9 CF series telephone preparation	277	201019
10.10 CF series anti-theft protection	277	201019
10.11 CF series refrigerator preparation	278	201019
10.12 CF series LED preparation immobiliser / Alarm.	278	201019
10.13 CF65 series ESC system	278	201019
10.14 CF65 series FMS system	290	201019
10.15 CF series trailer connection points	293	201019
10.16 CF75 - CF85 ESC system	294	201019
10.17 CF75 - 85 series FMS / DTS system	311	201019
10.18 CF series PTO control / protection	315	201019
10.19 Refuse preparation CF75 - CF85 Series	326	201019
10.20 Hydraulic Platform CF75 series	331	201019

BODYBUILDERS' GUIDELINES

Electrical system CF series

10.ELECTRICAL SYSTEM CF SERIES

10.1 CF SERIES CAB SWITCH AND CONNECTOR LOCATIONS

Switch positions, overhead console

- 1 Tachograph
- 2 Toll Collect (ECU) connector (See 12.48: "Connector D318 (ECU) Toll Collect".)
- 3 Switch working light on roof
- 4 Switch rotating beam
- 5 Spare / CB / telephone microfoon
- RES reserve points

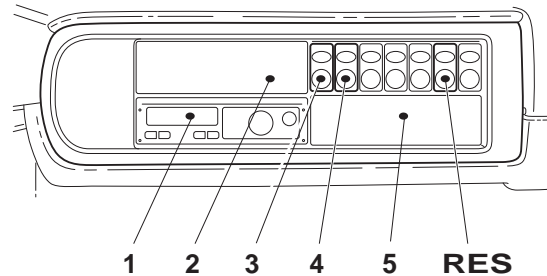

G001135

Switch positions, dashboard

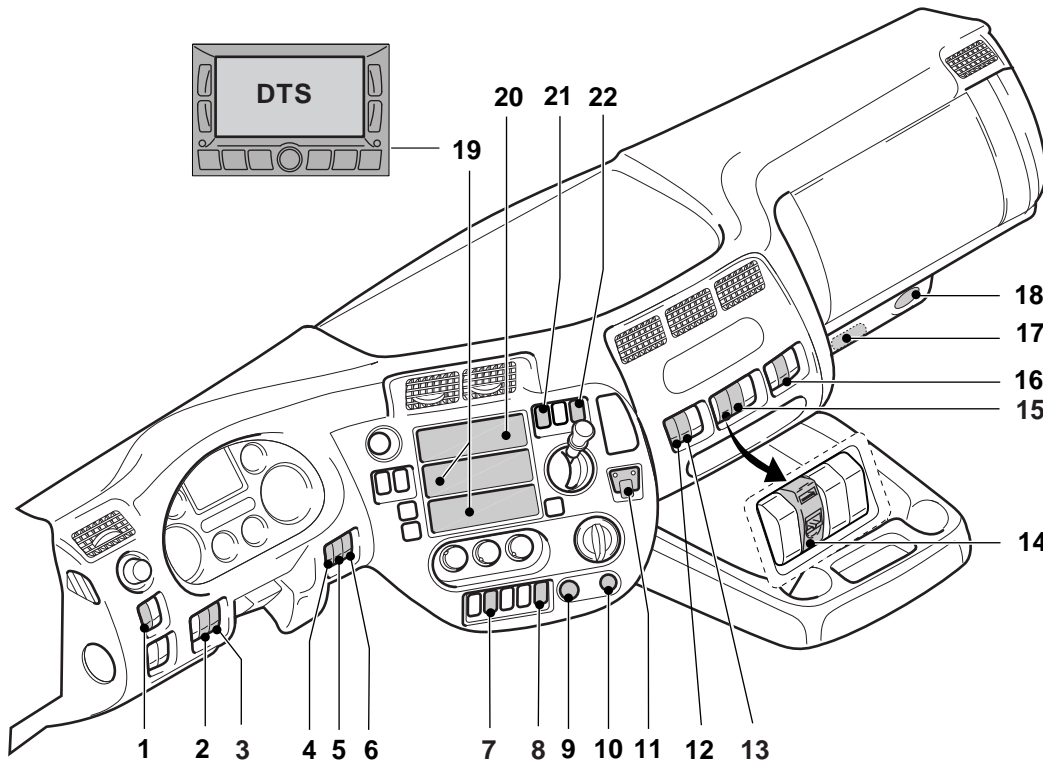

G001223

- | | |
|---|--|
| <ul style="list-style-type: none"> 1 Work lamp 2 Control light cargo lift active/open 3 Cargo lift 4 PTO 3 5 PTO 2 6 PTO 1 7 Stop & Go | <ul style="list-style-type: none"> 12 hazard switch 13 Main switch 14 DTS plug LAN and USB 15 reverse buzzer 16 Reserve 17 FMS connector location. (See 12.46: "Connector A138 FMS 12-pole".) 18 HD-OBD plug (See 12.33: "Connector A100 HD-OBD diagnose".) |
|---|--|

BODYBUILDERS' GUIDELINES

Electrical system CF series

- | | |
|---|--|
| <ul style="list-style-type: none"> 8 Surround lights Hydraulic platform 9 12V accessories plug with cigar lighter
(See 12.22: "Connector A011 accessories 12V 2-pole".) 10 24V accessories plug
(See 12.21: "Connector A007 accessories 24V 2-pole".) 11 Telephone carkit | <ul style="list-style-type: none"> 19 Storage recess 2 and 3 or DTS unit 20 Radio recess 1 21 Cross lock rear axle 22 Lane departure warning assistant |
|---|--|

For an overview of available switches and symbols, see section 7.14: "DAF dashboardpanel switches and indication lights".

10.2 CF SERIES BULKHEAD CONNECTION OVERVIEW

Bulkhead lead-through overview

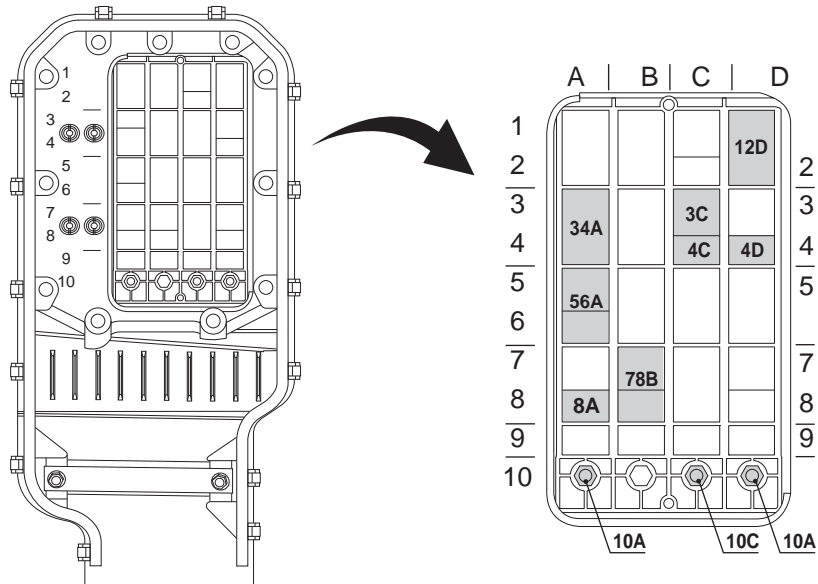

G001185

Connector location Codes ⁽²⁾	Description ⁽¹⁾
3C	Engine torque limiter, see section: 12.3: "Connector 3C engine torque limiter"
4C	Engine Speed Control, see section: 12.6: "Connector 4C ESC system"
4D	PTO control, see section: 12.7: "Connector 4D PTO control system"
8A	Refuse preparation, see section: 12.39: "Connector A113 garbage truck"
	Hydraulic platform preparation, see section: 12.41: "Connector A122 hydraulic platform 9-pole"
12D	Bodybuilder functions, see section: 12.11: "Connector 12D body builder"
34A	- Fleet Management Systems (FMS), see section: 12.31: "Connector A097 FMS system" (For general communication standard information, see section: 8.1: "Data communication CAN SAE J1939 / ISO 11898 (including FMS)")
56A	Accessories, see section: 12.13: "Connector 56A accessories"
78B	Refuse preparation, see section: 12.30: "Connector A095 application refuse collector"
	Hydraulic platform preparation, see section: 12.42: "Connector A123 hydraulic platform 21-pole"

(1) For pinning and wire numbers see the indicated sections.

(2) The here mentioned connector location codes sometimes are identical with the connector code of the actual plugged in connector.



WARNING! All signals mentioned in the tables explaining application connector pinning are active +24V (HS = High Side) and inactive open or 0V (LS = Low Side) unless stated otherwise!

Bulkhead lead-through for body functions (connector code 12D)

For the bodybuilding industry, a 21-pin application connector is available, as standard, in the bulkhead lead-through, so that the bodybuilder can subsequently simply take up signals, without interfering with the standard system. The following signals are available:



NOTE: The power supply **before** contact (Kl.30) is fused via fuse E142. The power supply **after** contact is fused via fuse E163. Both the fuses are designed for 25A current. Via E142 also other equipment, like rotating beacons, refrigerator, main beam lights etc. are fused.

The CAN wiring for CAN-H / CAN-L is available in the bulkhead lead-through following assembly of the "BODY BUILDER MODULE" (BBM), which can be ordered as an accessory. CAN wiring for body functions may be up to 40 metres long,

BODYBUILDERS' GUIDELINES

Electrical system CF series

provided that a terminal resistor of 120 ohms is installed at the end. The maximum length of the stubs must not exceed 1 metre. The twisted wiring, orange/yellow, with protection, must comply with SAE standard J1939/21.

Option BB-CAN

The option Body Builder CAN default provides communication only from the vehicle to the body. For applications involving the transmission of CAN messages to the vehicle, contact DAF. For special applications and specific customer requirements, DAF can supply the so-called BBM Full, which is described in section 8.4: "Body Builders' Module (Optional)". This offers the possibility of tailor-made solutions.

10.3 CF75 AND CF85 SERIES CHASSIS CONNECTIONS



NOTE: Following information is NOT valid for CF65 chassis. For these vehicles see section 9.3: "LF and CF65 series chassis connections".

Locations of application connectors

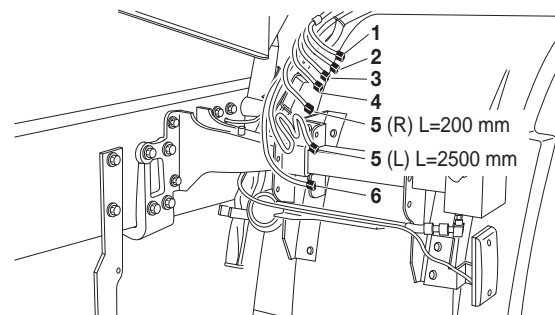

G000541

Position	Connector Code	description ⁽¹⁾
1	A068	Application connector for engine speed control; see section: 12.26: "Connector A068 (chassis - ESC system)"
2	A070	Application connector for superstructure; see section: 12.27: "Connector A070 accessories 8-pole"
3	A102	Application connector for body function spare wires (12-pin); see section: 12.34: "Connector A102 body builder 8-pole"
4	A103	Application connector for body function signals (8-pin); see section: 12.35: "Connector A103 bodybuilder 12-pole"
5		Connection for side markers (2x)
6	A105	Application connector BB-CAN chassis; see section: 12.37: "Connector A105 Bodybuilder CAN system 7-pole"

(1) Check out the indicated sections for additional information on offered functionality, pinning and wire numbers within the connectors used.

Side marker lights

At the position of the first side marker behind the cab, on right-hand side, there are two cables with a 2-pin connector. Both connectors contain wire numbers 2102 and 2103. Side markers and top lights can be connected from here using the cable harnesses that are mentioned in chapter 13.6: "Electric cable contour lights chassis"

10.4 CF SERIES ACCESSORIES CONNECTIONS

Wiring headershelf Space Cab

There are several connectors available in the headershelf at the driver side.

- 9-pin connector 182C: in section 12.15: "Connector 182C power supply".
- 12-pin connector 183C: in section 12.16: "Connector 183C power supply".

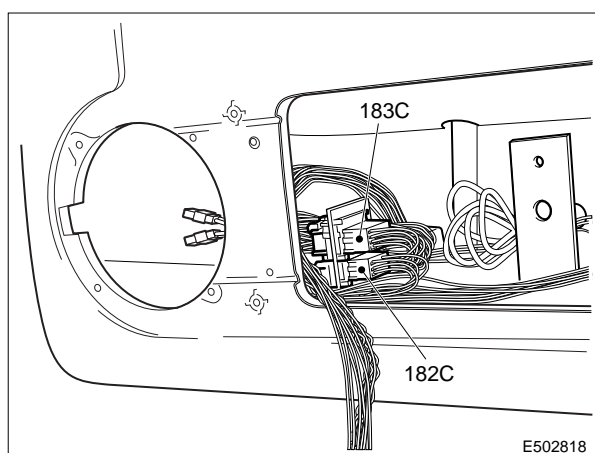

Spare wiring

There is no spare wiring from dashboard area via the A-pillar to the headershelf.

BODYBUILDERS' GUIDELINES

Electrical system CF series

10.5 CF SERIES ACCESSORIES CONNECTION IN DASHBOARD

Spare wiring from dashboard area to bulkhead lead-through

The wiring runs from a 18-pole connector (A104) behind the radio compartment to the bulkhead lead-through 12D. The number of spare wires is 11, except when a FMS preparation is present. In this case spare wire A1 is used as wire 3772 panic button input for the FMS system. For details see 8.1: "Data communication CAN SAE J1939 / ISO 11898 (including FMS)".

Check the sections indicated below for additional information on pinning and wire numbers within the connectors used:

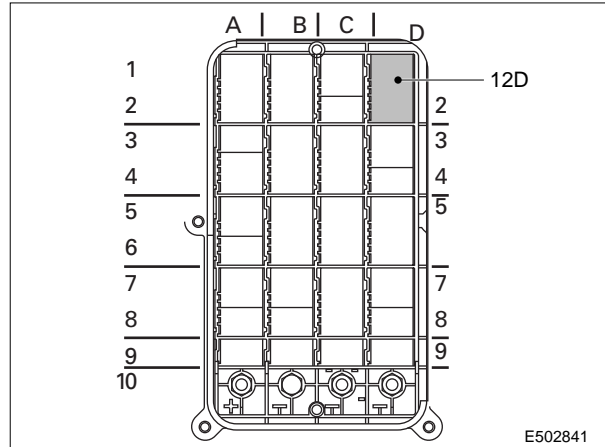

Connector 12D

- connector A104 in section:
12.36: "Connector A104 spare wiring 18-pole" .
- connector 12D in section:
12.11: "Connector 12D body builder".

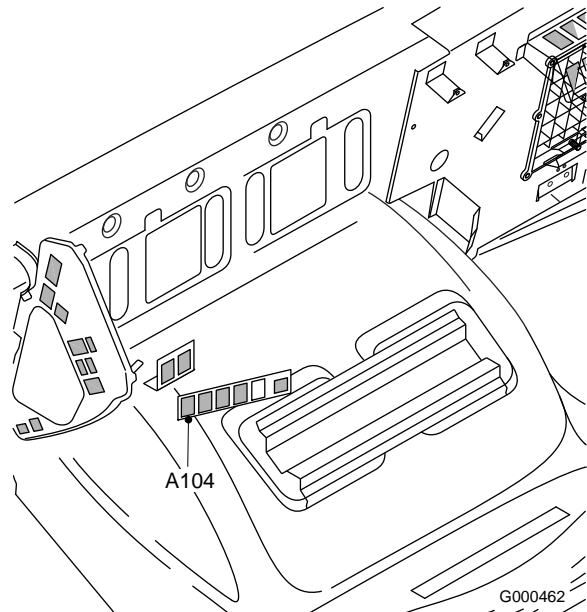

Connector A104

10.6 CF SERIES POWER SUPPLY

Power Supply

The power supply for all accessories should be taken from connector 12D in the bulkhead lead-through.

For details on pinning see chapter 12.11: "Connector 12D body builder".

- Power supply - 24V/25A before contact, wire number 1154, and 24V/25A after contact, wire number 1258 - is available in the 6-pin green connector in the central box behind the fuse/relay board. In this connector, the signals 'engine running' (3157), 'cab locking' (3412) and 'earth' (2x) are also available.
- 24V/40A power supply, before contact, is available in the 2-pin connector in the central box behind the fuse/relay board. Wire numbers: 1175 and M.
- 24V/10A via the accessory plug on the dashboard, beside the lighter position.

Remember the total permissible power supply as stated in section 7.9: "Maximum load".

Beside this 24V connection, there are two earth connections, M8 screw version, in positions 10C and 10D, in the bulkhead lead-through.

12V/10A or 12V/20A (optional) power supply is available behind the panel of the central console for radio and telephone, and in the overhead console for CB and fax (see below).



WARNING! The 24V connections on the bulkhead lead-through (10A) and on the distributor block behind the foot panel on the co-driver's side are all un-fused and must not be used for power supply unless separately fused within 10 cm from the connection.



NOTE: a maximum of 3 ring connectors per bolt connection.

Accessories preparations

Several preparations are standard in the CF series cab.

40A power supply preparation

This is a 2 pole connector (connector code A038). Designed for currents up to 40 A!. See section: 12.23: "Connector A038 accessories". The wires 1175 (KI30) and M22 (earth) are both 4,0 mm². The powersupply is taken via fuse E168 KI30 (before contact). The fuse is a MAXI FUSE, located on the top side of the fuse-relay board. See also chapter 7.4: "Earth connections".

10.7 CF SERIES RADIO PREPARATION

8304: no radio, no speakers
8305: no radio, with basic speakers
8450: no radio, with luxury speakers

BODYBUILDERS' GUIDELINES

Electrical system CF series

8508: basic radio/CD player

8562: luxury radio/CD player



WARNING! The standard version 24/12V converter is 10A. A 20A version is available. The total current consumption from the 12V supply before and after contact for telephone, fax, radio and CB together, must not exceed the specified value. Splitting of the 12V circuit using more than one converter is necessary if additional current consumption is required. Installing a heavier-duty converter is not recommended, in view of cable diameters and suppression.

Radio preparation

For the radio connection, an ISO connector is fitted behind the radio panel, with 12V/10A power supply before contact (wire 1108), power supply after contact (wire 1363, switched via relay G377) and earth (M). Also, for the loudspeakers, the wiring to the door, A-pillar (for tweeters) and rear wall (for loudspeakers) has been prepared as standard. If tweeters are installed, a dividing filter must be fitted.

Position	Connector	Description
A	D347.A	Power supply 24V radio
	238C	Power supply 12V radio
B	D347.B	Loudspeakers radio

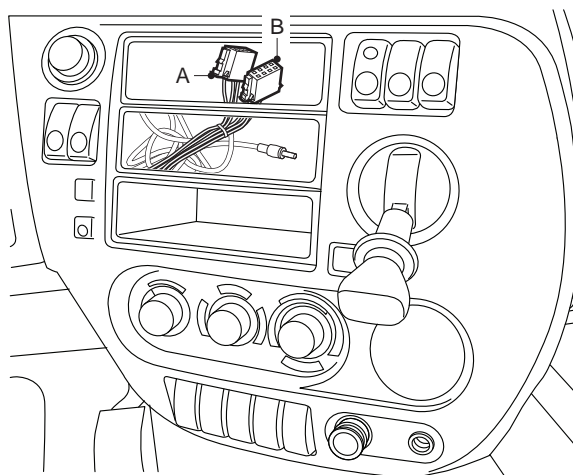

G001220

10



WARNING! If a vehicle is ordered without radio (selco 8304, 8305 or 8450) the three above mentioned connectors are available were connector D347.A is tightened up. If a vehicle is ordered with radio (selco 8508 or 8562) only connector D347.A and D347.B are available. When the vehicle needs to be rebuild from 24V into 12V radio an extra wiring loom has to be ordered at DAF.

10.8 CF SERIES CB PREPARATION

CB preparation

In the headershell there is a 2-pole white connector (connector code B026) containing the wires 1108 (+12V, KI30) en M515 (earth). These are meant for connecting CB or fax equipment.

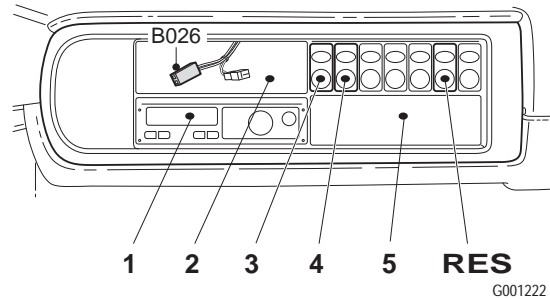

G001222

10.9 CF SERIES TELEPHONE PREPARATION

Telephone preparation

For a telephone connection, space has been reserved on the right-hand side of the radio panel. An AMP plug is fitted as standard behind the radio panel, with 12V/10A power supply before contact (wire 1108), 12V/25 mA power supply after contact (wire 1353) and earth (M).

Check the section 12.28: "Connector A076 telephone" for additional information on pinning and wire numbers within this connector used.

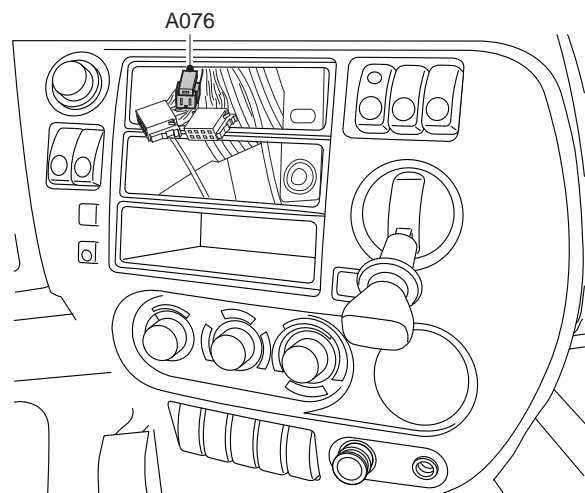

G001221

10.10 CF SERIES ANTI-THEFT PROTECTION

CF series

If the vehicle is fitted with the standard anti-theft protection system, the body can be connected to the vehicle system via the application connector accessories.

See section 10.3: "CF75 and CF85 series chassis connections" and 9.14: "LF series trailer connection points".

Wire numbers 3659 and 3660 are both inputs connected to **ground** via a switch. If interrupted, the alarm will sound. Wire 3651 is a 12 V supply coming from the alarm system, and meant for the power supply of the interior motion detection.

BODYBUILDERS' GUIDELINES

Electrical system CF series



WARNING! For the latest details and versions, contact DAF.

10.11 CF SERIES REFRIGERATOR PREPARATION

Refrigerator preparation

The refrigerator wiring is standard prepared and can be found in the lower bed bunk. In this connector (connector code B356) the wires 1154 (+24V, KI30) en M72 (earth) can be found.



NOTE: The powersupply 1154 runs via fuse E142. Via this fuse also other functions are secured among which as rotating beacons, bodybuilder application connector etc. See section 7.13: "Connection points and permitted power loads" for the maximum permitted load on fuse E142.

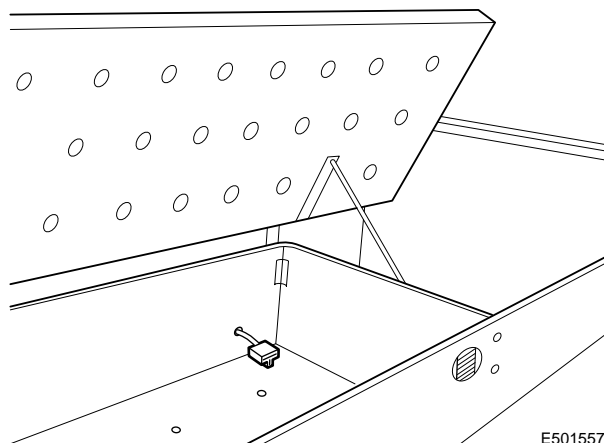

10.12 CF SERIES LED PREPARATION IMMOBILISER / ALARM

LED preparation immobiliser / Alarm

In the headershell there is a 2-pole black connector (connector code 143C). The wire 1107 and 3482 are meant for connecting the LED of the immobiliser.

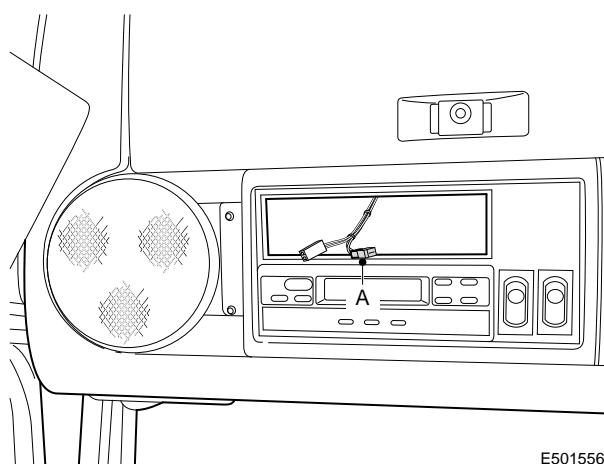

10.13 CF65 SERIES ESC SYSTEM

CF65 Series ESC control

Applicable application connectors in cab and chassis depending on selection code:

0761: without engine speed control connector
 0797: with engine speed control cab connector
 9231: with engine speed control chassis connector



NOTE: Connector 4C is always present due to standardisation if selco 0797 is selected including correct BBM software.

For part numbers of the bulkhead connectors check chapter 13.4: "Electric connector parts cabine (CF75-85 and XF Series)".

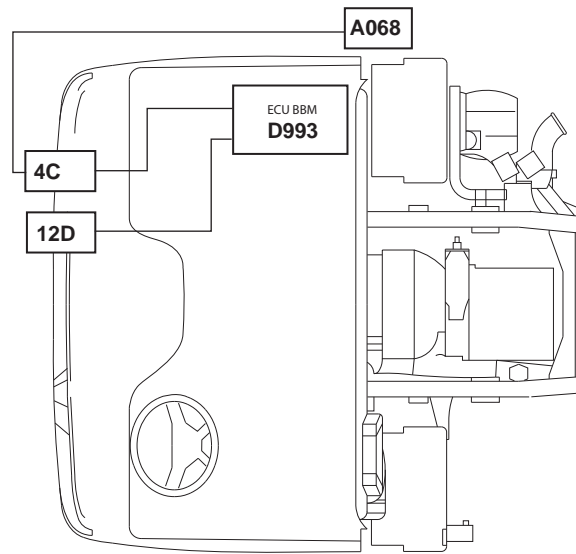

G001166

Check out the sections indicated below for additional information on pinning and wire numbers within the connectors and ECU units used:

connector A068 in the vehicle chassis: see section 12.26: "Connector A068 (chassis - ESC system)".
 connector 4C in the bulkhead: see section 12.6: "Connector 4C ESC system".

Purpose of the function

The purpose of the engine speed control system is to enable the engine speed to be adjusted between idling speed and the maximum speed. This adjustable engine speed is used, among other things, to drive auxiliary consumers via a PTO. The engine speed control can be used while driving or when idling by setting the correct customer parameters using DAVIE. The engine speed control can be enabled by the driver using the steering wheel switches, if the correct selection codes have been chosen, through the superstructure equipment via the relevant application connector (A068 hardwired). Enabling the engine speed control via one of the application connectors takes priority over the steering wheel switches.

Schematic overview of ESC system control

The diagram below provides a schematic overview of the engine speed control. The two main groups for controlling the engine speed control can be identified as follows:

1. Enabling engine speed control by the driver via the VIC (Vehicle Intelligence Centre)
 - Steering wheel switches
 - Steering column switch

BODYBUILDERS' GUIDELINES

Electrical system CF series

2. Enabling engine speed control by the body via the BBM (Body Builder Module)

- Cab application connector (4C connector)
- Chassis application connector (A068 connector)

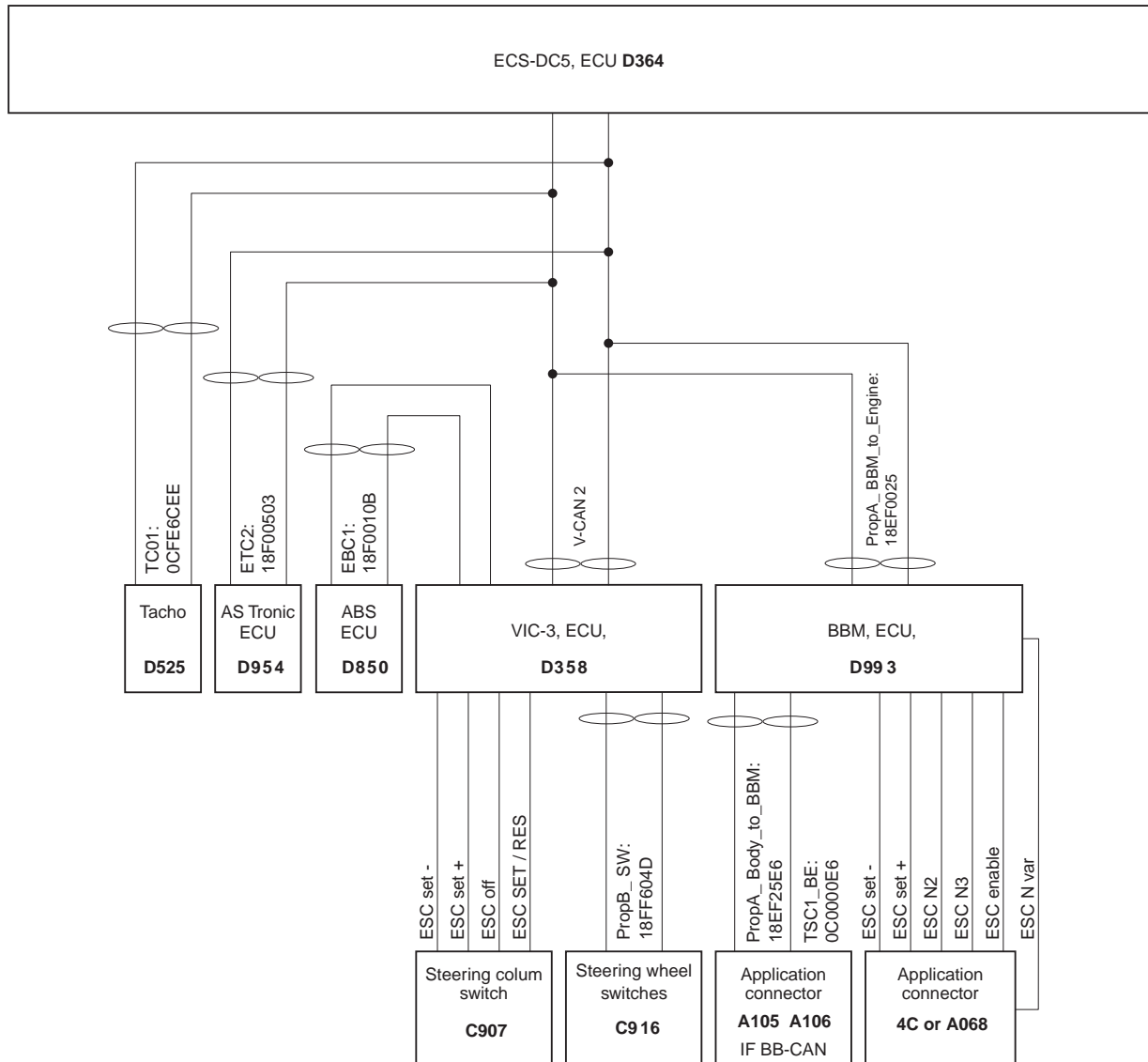

G001143

General ESC system layout (VIC3 - ECS-DC5)

CAN signal description				
CAN Message name	Message id	Used CAN Signals for ESC	Startbit	Length
TC01	0CFE6CEE	Tachograph vehicle speed	48	16
PropB_SW	18FF604D	Cruise control resume switch	16	2
		Cruise control off switch	18	2
		Cruise control accelerate switch	20	2
		Cruise control coast switch	22	2

CAN signal description				
CAN Message name	Message id	Used CAN Signals for ESC	Startbit	Length
CCVS	18FEF100	Parking brake switch	2	2
		Cruise control active	24	2
		Cruise control enable switch	26	2
		Brake switch	28	2
		Clutch switch	30	2
		Cruise control set switch	32	2
		Cruise control coast switch	34	2
		Cruise control resume switch	36	2
		Cruise control accelerate switch	38	2
		Cruise control set speed	40	2
		Cruise control state	53	2
EBC1	18F0010B	EBS brake switch	6	2
ETC2	18F00503	Selected gear	0	8
PropA_ BBM_ to_Engine	18EF25E6	Engine start	42	2
		ESC enable	48	2
		ESC set minus	50	2
		ESC n variabel	52	2
		ESC set plus	54	2
		Application speed limiter	56	2
		ESC N2	58	2
		ESC N3	60	2
		Engine stop	62	2

Enabling engine speed control by the driver

As is evident from the schematic overview, the VIC can receive the engine speed control signals from the steering wheel switches (via CAN) or via the steering column switch (hardwired). The VIC translates these signals into a CAN message, which is sent to the engine control unit. The steering column switches and the steering wheel switches have the same engine speed control operating functions, namely: "SET+", "SET-", "SET", "RESUME" AND "OFF".

BODYBUILDERS' GUIDELINES

Electrical system CF series

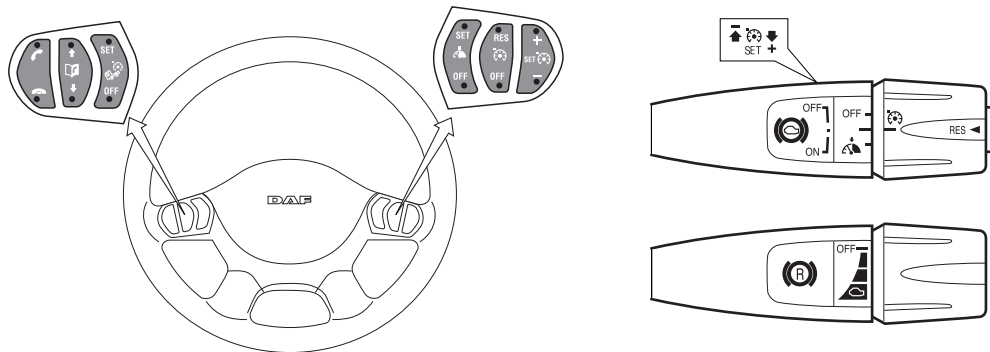

Steering wheel switches and stalk lever switches.

G000391

Operating functions of the steering wheel switches		
Function	Standard setting	Choices in ECS-DC5 (D364) via DAVIE (CP = customer parameter)
SET + SET -	Brief operating ⁽²⁾ of "SET +" during engine speed control activates the set speed engine speed. The activation reacts on the falling edge of the signal.	CP 2-16
	Brief operation ⁽²⁾ of "SET -" during engine speed control activates the resume speed engine speed. The activation reacts on the falling edge of the signal.	CP2-17
	Long operation ⁽¹⁾ of "SET +" during engine speed control gives a continuous increase of the preset desired speed (default 250 rpm/s). This function can only be enabled after activation of the set speed once.	0<ramp<400 [rpm/s] CP2-22
	Long operation ⁽¹⁾ of "SET -" during engine speed control gives a continuous decrease of the preset desired speed (default 250 rpm/s). This function can only be enabled after activation of the set speed once.	0<ramp<400 [rpm/s] CP2-22
	The desired engine speed can be varied using "set +/-" between minimum and the maximum speed to be set.	N_idling<speed limit<N_max (rpm) via CP2-15 and CP2-14
Res	Operating "Res" activates the engine speed control and sets the engine speed to the value entered using CP2-17 (default 1200 rpm). Activation by operating "Res" (resume) button twice. With this "Res" button the operation can toggle between N1 and N2..	To be set using CP2-17 between the values set using CP2-14 and CP2-15
OFF	Engine speed control is switched off using the "OFF" button.	

(1) Long operation: touch time>0,1s

(2) Brief operation: touch time<0,1s

Switch on and off conditions

To make engine speed control possible, a number of (default) cut-in conditions must be met, namely:

- The handbrake must be engaged. (CP2-32)
- The vehicle speed must not be faster than 10 km/h. (CP2-11)
- Clutch pedal is not operated. (CP2-34)

- Brake pedal is not operated. (CP2-33)
- Engine brake foot pedal is not operated. (no CP)

In addition, there are a number of faults that can be checked, which, if active, prevent the engine speed control from being activated.

- No faults are active that relate to vehicle speed.
- No faults are active that relate to Set+/Set-plausibility
- No faults are active that relate to engine speed.
- No faults are active that relate to CAN communication.
- No faults are active that relate to clutch signal plausibility.
- No faults are active that relate to handbrake signal.
- No faults are active that relate to clutch signal.
- No faults are active that relate to a neutral gearbox signal.

If, for the body function, it is necessary to deviate from the standard options tested and released by DAF, DAF shall no longer be responsible for the operation. The implementation of non-standard body functions and the possible consequences are the responsibility of the user (generally the bodybuilder), who then bears product liability.

If the above conditions are met, the application connector can be used in various ways to activate the engine speed control, namely via:

	Hardwired or CAN	Activation	Priority ⁽¹⁾
Application connector	Hardwired	ESC enable	1
PropA_Body_to_BB	CAN	ESC enable	2

(1) If a unit is active and a unit with a higher priority is activated, the unit with the highest priority will become active immediately. Only one unit of the above variations can be active, so no combination of various units is possible.

The above table indicates that hardwired activation has the highest priority followed by activation via CAN.

BODYBUILDERS' GUIDELINES

Electrical system CF series

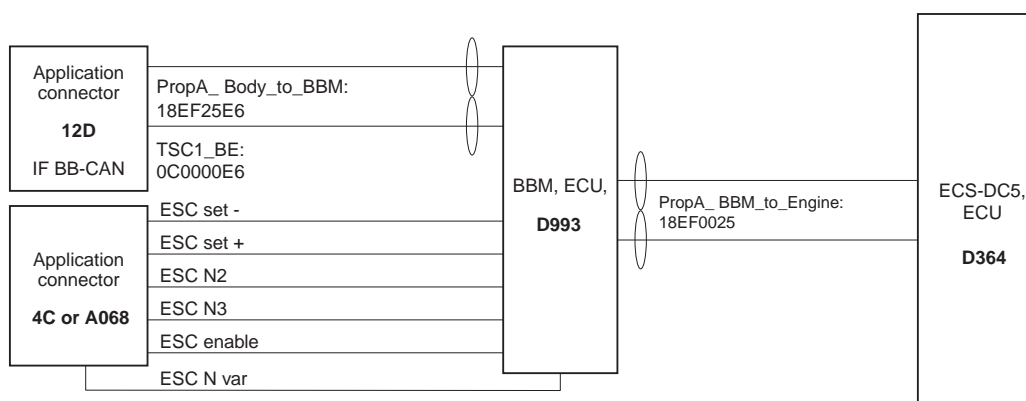

G001144

Hardwired activation of engine speed control

For operating the engine speed control through the body connection (see relevant selco's), the same functions, cut-in and cut-out conditions, and customer choices are offered as for the engine speed control through the steering wheel or column switch. The functions "SET+" and "SET-" are controlled using pulse and continuous signals. Via the hardwired input on the application connector, two engine speeds N2 or N3 are to be reprogrammed and a variable speed (Nvar) are also to be activated. To activate these speeds the engine speed control first must be enabled by providing a high signal on pin 7 of the cab connector 4C or chassis connector A068. Then N2 and N3 can be activated providing a high signal on pins 10 and 11 respectively of this connector and if a high signal is provided on pin 8 of the above connectors, Nvar is activated. It is not possible to wire the ESC enable and N2 or N3 together to switch ESC on. The ESC enable must be switched on before the required set speed is switched on.

10

Operating functions of the application connector (4C or A068)		
Function ⁽¹⁾	Standard setting	Choice in ECS-DC5 via DAVIE (CP = customer parameter)
Enable ESC	If the engine speed control function is activated and the vehicle speed is lower than the limiting speed for engine speed control + 5 km/h, the engine speed control is enabled through the body connection. At the same time, operation via the steering column switch is blocked.	
SET + SET - Pulsing ⁽²⁾ or continuous ⁽³⁾	Operating "SET+/-" switches the engine speed control on and sets the current engine speed as the desired speed (constant value).	
	Brief operation of "SET +/-" during engine speed control gives a stepped increase or reduction of the engine speed (default 25 rpm).	0<step<400 [rpm] via CP2-20 and CP2-38
	Long operation ⁽⁴⁾ of "SET +/-" during engine speed control gives a continuous increase or reduction of the preset desired speed (default 200 rpm/s).	0<ramp<400 [rpm/s] via CP2-18 and 2-19
	When "SET+/-" is released, the current engine speed is set as the new desired engine speed	
	The desired engine speed can be varied using "SET +/-" between the minimum and the maximum speed to be set.	N_idling<speed limit<Nmax (0 rpm) via CP2-15 and CP2-14
N_variable	Operating "Enable N_variable" activates the engine speed control and sets the last desired engine speed set using SET+ and SET-. This value is also memorised when the ignition is switched off. Varying the desired speed is possible using SET+/- but only if the input "Enable N_variable" is activated.	
N_2	Operating "N2" activates the engine speed control and sets the engine speed to the value entered using CP2-16 (default 800 rpm).	To be set using CP2-28 between the values set using CP2-15 and CP2-14
N_3	Operating "N3" activates the engine speed control and sets the engine speed to the value entered using CP2-17 (default 1200 rpm).	To be set using CP2-29 between the values set using CP2-15 and CP2-14
V_max application ⁽⁵⁾	If the Vmax application input is activated by providing a 24 V signal, the vehicle speed is limited to the pre-programmed value (default 30 km/h).	Adjustable using CP2-10 between a value of 10 and 24km/h ⁽⁶⁾
Engine speed	Output signal, square-wave, 30 pulses per revolution; LS pulse	

(1) If operated simultaneously, the priority is as follows (high to low): "enable ESC", "N2", "N3", "Nvar" (set+/-)

(2) Pulse signal; when rising edge reaches value of 0,6xUbat

(3) Continuous signal; "high" at a voltage level of 0,6xUbat and "low" if below a level of 0,4xUbat

(4) Long operation; touch time>0,1s

(5) Special applications (e.g. refuse vehicles)

(6) Contact Sales engineering for speed limit higher than 24km/h

BODYBUILDERS' GUIDELINES

Electrical system CF series

Activation of engine speed control via CAN message PropA_Body_to_BBM

In addition to calling up two, pre-set target speeds via the hardwired option, it is also possible, providing selection code 9562 "with application connector body builder CAN" has been chosen, to activate these target speeds via CAN. To be able to use this functionality, the body must provide CAN message PropA_Body_to_BBM with identifier 18_EF_25_E6 to pin 17 and 18 of connector 12D. The data that must be provided in this message is as follows:

Signal name	Byte	Bit	Type	Offset	Min	Max	Unit	Comments
ESC enable	7	2,1	Status	-	0	3	-	00 _b =passive 10 _b =error 01 _b =active 11 _b =not available
ESC set min	7	4,3	Status	-	0	3	-	00 _b =passive 10 _b =error 01 _b =active 11 _b =not available
ESC N variable	7	6,5	Status	-	0	3	-	00 _b =passive 10 _b =error 01 _b =active 11 _b =not available
ESC set plus	7	8,7	Status	-	0	3	-	00 _b =passive 10 _b =error 01 _b =active 11 _b =not available
ESC N2	8	4,3	Status	-	0	3	-	00 _b =passive 10 _b =error 01 _b =active 11 _b =not available
ESC N3	8	6,5	Status	-	0	3	-	00 _b =passive 10 _b =error 01 _b =active 11 _b =not available
Engine requested Speed Control Conditions	5	4,3	Status	-	0		-	00 _b =override disabled 01 _b =Speed control 10 _b =Torque control 11 _b =Speed/Torque limit control

BODYBUILDERS' GUIDELINES

Electrical system CF series

Signal name	Byte	Bit	Type	Offset	Min	Max	Unit	Comments
Engine Override Control mode	5	-2,1	Status	-	0	3	-	00 _b =Transient optimized for driveline disengaged and non-lockup conditions 01 _b = Stability optimized for driveline disengaged and non-lockup conditions 10 _b = Stability optimized for driveline engaged and/or in lockup condition 1 11 _b = Stability optimized for driveline engaged and/or in lockup condition 2
Engine requested Speed/ Speed limit	4,3		Value	-	0	803 1,87 5	Rpm	
Engine requested Torque/ Torque limit	2		Value	-125	-125	125	%	

In message PropA_Body_to_BBM the commands that are provided through the hardwired option may also be provided via CAN, as is evident from the table. In addition, contrary to earlier releases, a torque/speed limit can be forced via this message by selecting the correct CAN configuration of the message provided. This function makes it possible to select any speed between the limits defined using customer parameters (2-14 and 2-15) via the Body Builder CAN.

By way of clarification, an example of the content of the PropA_Body_to_BBM message is given below.

PropA_Body_to_BBM (18 EF 25 E6)												
Name	Source	Destination	Direction	Data Length Code	DATA: 01 00 E2 04 F0 F7 41 04							
PropA_Body_to_BBM	E6	5	X	8	Byte 1	Byte 2	Byte 3	Byte 4	Byte 5	Byte 6	Byte 7	Byte 8
					01	00	E2	04	F0	F7	41	04

10

BODYBUILDERS' GUIDELINES

Electrical system CF series

signal	Physical value	Byte / bit number	(b) = Binair (h) = Hexagonal value	Comment
Requested_Torque_Torque_limit	-125%	Byte 2	00(h) 0000 000(b)	Physical value = (CAN data x rise/scale) + offset = (0 x 1/1) + (-125) = -125%
Requested_Speed_Speed_limit	1250 rpm	Byte 4,3	04 E2(h) 0000 0100 1110 0010(b)	Physical value = (CAN data x rise/scale) + offset = (1250 x 1/1) + 0 = 1250 rpm
Requested_Speed_Control_Condition	00 _b = override disabled	Byte 5 bit 4,3	F0(h) 1111 0000(b)	(00)
Override_Control_Mode	00 _b =Transient optimized for driveline disengaged and non-lockup conditions	Byte 5 bit 2,1	F0(h) 1111 0000(b)	(00)
ESCn3	00 _b =passive	Byte 8 bit 6,5	04(h) 0000 0100(b)	(00)
ESCn2	01 _b =active	Byte 8 bit 4,3	04(h) 0000 0100(b)	(01)
ESCn_variable	00 _b =passive	Byte 7 bit 6,5	41(h) 1000 0001(b)	(00)
ESC_set_plus	01 _b =active	Byte 7 bit 8,7	41(h) 0100 0001(b)	(01)
ESC_set_minus	00 _b =passive	Byte 7 bit 4,3	41(h) 1000 0001(b)	(00)
ESC_enable	01 _b =active	Byte 7 bit 2,1	41(h) 0100 0001(b)	(01)
Engine_stop	00 _b =passive	Byte 8 bit 8,7	04(h) 0000 0100(b)	(00)
Engine_start	01 _b =active	Byte 6 bit 4,3	F7(h) 1111 0111(b)	(01)
Application_speed_limiter	00 _b =passive	Byte 8 bit 2,1	04(h) 0000 0100(b)	(00)

In addition to various cut-in conditions, the cut-out conditions must also be taken into account. These cut-out conditions are:

- The handbrake must be disengaged. (CP2-32)
- The vehicle speed is higher than limit value + offset (10+5=15 km/h). (CP2-11)
- Clutch pedal is operated. (CP2-34)
- Brake pedal is operated. (CP2-33)
- Engine brake foot pedal is operated. (no CP)

In addition, there are a number of faults that are checked and if active, the engine speed control should be switched off:

- A vehicle speed fault is active.

- A plausibility fault is active on the set+/set-switches.
- An engine speed fault is active.
- A fault that relates to the CAN communication is active.
- A plausibility fault is active that relates to the clutch signal.
- A fault is active that relates to the handbrake signal.
- A fault is active that relates to the clutch signal.
- A fault is active that relates to the neutral signal of the gearbox.

In addition to the cut-in and cut-out conditions, the system also has a number of overrule conditions. An overrule condition means that the control under which the system is operating at that point is temporarily suppressed. These overrule conditions are:

- Accelerator pedal operation. (CP 2-30)
The accelerator pedal can be used to temporarily increase the engine speed up to a maximum value preset under customer parameter 2.14 (max. ESC speed).
- Exceeding vehicle speed limit. (CP 2-11)
- ASR activation.
- Speed limiter activation.

Customer ⁽¹⁾ parameter	ENGINE SPEED CONTROL		
2-14	MAX ESC SPEED.	DMCI	Rpm
2-15	MIN ESC SPEED	DMCI	Rpm
2-16	ACCELERATION RAMP CONTINUOUS DOWN ESC	DMCI	Rpm/s
2-17	ACCELERATE UP PER TIP	DMCI	Rpm/tip
2-21	DECELERATE DOWN PER TIP	DMCI	Rpm/tip
2-22	ACCELERATE FROM IDLE TO TARGET SPEED IN ESC	DMCI	Rpm/s
2-27	ESC CHANGE STEERING COLUMN N VARIABLE	DMCI	Rpm
2-28	ESC CHANGE APPLICATION CONN. N2	DMCI	Rpm
2-29	ESC CHANGE APPLICATION CONN. N3	DMCI	Rpm

(1) For changing default parameter settings see chapter 7.19: "Guideline for the Customer Parameter Change Form"

BODYBUILDERS' GUIDELINES

Electrical system CF series

Customer ⁽¹⁾ parameter	ENGINE SPEED CONTROL CONDITIONS		
2-30	ACCEL. PEDAL	DMCI	ACTIVE / NOT ACTIVE
2-31	MAX RPM ACCELERATOR PEDAL	DMCI	Rpm
2-32	PARK BRAKE	DMCI	ACTIVE / NOT ACTIVE
2-33	BRAKE	DMCI	ACTIVE / NOT ACTIVE
2-34	CLUTCH	DMCI	ACTIVE / NOT ACTIVE

(1) For changing default parameter settings see chapter 7.19: "Guideline for the Customer Parameter Change Form".

10.14 CF65 SERIES FMS SYSTEM

Applicable selection codes:

8360: without Fleet Management System
 6407: with Fleet Management System preparation
 9990: with DAF Telematics System preparation
 1075: with DAF Telematics System

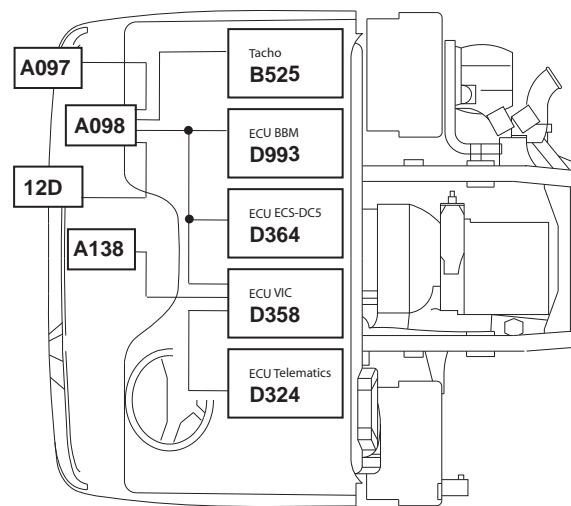

G001167

Applicable FMS application connectors cabine:

Check out the sections indicated below for additional information on pinning and wire numbers within the connectors and ECU units used:

connector A098: in section 12.32: "Connector A098 FMS system".
 connector A097: in section 12.31: "Connector A097 FMS system".
 connector A138: in section 12.46: "Connector A138 FMS 12-pole".

Purpose of the function

FMS stands for **F**leet **M**anagement **S**ystem and is used to provide information about condition of the vehicle to the fleet owner for logistic purposes. The (wireless) transmission of the data from vehicle to user is performed by a third party ECU which will get the data provided by the VIC-3 via de D-CAN interface.

The main vehicle manufacturers, including DAF, have together agreed on the data to be universally provided for these FMS systems via the CAN link. Third parties are able to connect and to get the data from the truck CAN bus system. This document describes which D-CAN messages will to be supported via the FMS prepared selco 6407 or the DTS (DAF Telematics System) prepared selco 9990.

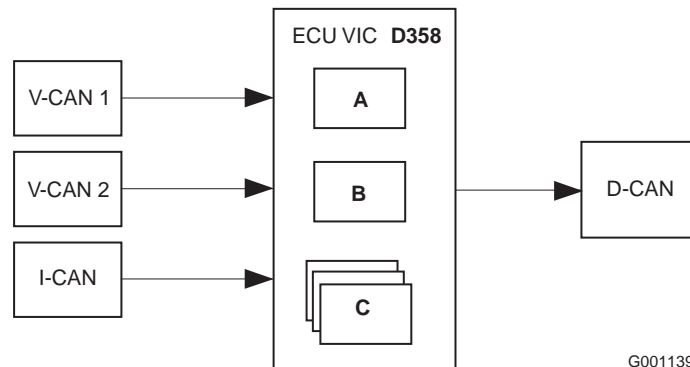

G001139

- A D-CAN gateway for FMS standard messages
- B D-CAN gateway for additional DTS messages
- C PLC functions

From week 2008-13 in total three connectors are available for connecting to the D-CAN bus were the FMS messages will be broadcasted. One of these three connectors is the standardised 12-pins FMS connector and is called A138.

A Fleet Management System needs some specific information to know which CAN-data is available and how to handle this CAN-data. This information is send in the CAN-message "FMS standard software version supported". This CAN-message is accepted by SAE J1939. Before there was no standard CAN-message and DAF would send the CAN-message "FMS standard information".

The following table describes the amount of data which will be send by DAF on the D-CAN for FMS preparation and DTS preparation.

BODYBUILDERS' GUIDELINES

Electrical system CF series

Message	Message ID ⁽¹⁾	Repetition Rate (ms)	FMS Prepared Selco 6407	DTS Prepared Selco 9990
EEC2	0C F0 03 00	50	X	X
EEC1	0C F0 04 00	20	X	X
Engine hours revolution	18 FE E5 00	On request	X	X
Vehicle Identification	18 FE EC EE	On request	X	X
High Resolution Vehicle Distance	18 FE C1 EE	1000	X	X
TC01	0C FE 6C EE	50	X	X
Engine temperature	18 FE EE 00	1000	X	X
Fuel economy	18 FE F2 00	100	X	X
Service	18 FE C0 27	1000	X	X
Dash display	18 FE FC 27	1000	X	X
FMS standard interface	1C FD D1 27	10000	X	X
Fuel consumption	18 FE E9 00	1000	X	X
DM1	18 FE CA XX	1000		X
TP_DT (BAM)	1C EB FF XX	-		X
TP_CM	1C EC FF XX	-		X
DM1 VIC	18 FE CA 27	1000		X
TP_DT (BAM)	1C EB FF XX	-		X
TP_CM	1C EC FF XX	-		X
PropB_BBM	18 FF 82 25	250		X
ERC1_XR	18 F0 00 29	100		X
ERC1_DR	18 F0 00 10	100		X
EBC1	18 F0 01 0B	100		X
Ambient conditions	18 FE F5 00	1000		X
Inlet / exhaust conditions	18 FE F6 00	500		X
Engine fluid level pressure	18 FE EF 00	500		X
Time date	18 FE E6 EE	1000		X
Tank information #1	18 FE 56 3D	1000		X
Driver information	18 FE 6B EE	On request		X
Combination vehicle weight	18 FE 70 0B	On request		X
ETC2	18 F0 05 03	100		X
Operator wiper and washer controls	18 FD CD 27	100		X
Operator external Light controls	18 FD CC 27	100		X
Cab illumination	18 D0 FF 27	5000		X
Vehicle hours	18 FE EC 27	1000		X

(1) For detailed message content see equivalent documents ("FMS CAN message overview.pdf" or "DTS CAN message overview.pdf") on the information sheet web page. (The Internet URL for the corporate DAF website is: www.daf.com -> follow the main menu item: "Products" -> Bodybuilder guidelines webpage -> Information Sheet webpage)

Terminator resistor D-CAN

FMS and DTS prepared are connected at the end of the D-CAN bus and therefore a terminator resistor is required. Vehicles with FMS prepared are ex-factory equipped with a terminator resistor in connector A098 on pin 10 and 11. Depending on the connected FMS system (with or without internally terminator resistor) one terminator resistor has to be fitted at the end of the D-CAN bus. In the table below the different situations are described.

	Terminator resistor in A098	Terminator resistor in A138
No FMS system connected	Yes	No
FMS with internal terminator resistor	No	No
FMS connected to A098 without terminator resistor	No	Yes
FMS connected to A138 without terminator resistor	Yes	No

10.15 CF SERIES TRAILER CONNECTION POINTS

A 24V electric trailer connection is standard for all vehicle types.

The electric sockets are located on a bracket behind the cab for tractors and mounted below the drawbar cross member for rigid.

Different arrangements are possible for the lighting and accessory connections namely:

1. Two 7-pin sockets (not in combination with safety regulations ADR)
 1. Standard Lighting connector A000; see section 12.18: "Connector A000 trailer system (ISO1185 type 24N)"
 2. Accessories connector A001; see section 12.19: "Connector A001 trailer system (ISO3731 type 24S)"
2. One 15-pole socket with locking device (if ADR is specified)
 1. Accessories connector A058; see section 12.25: "Connector A058 trailer system (ISO12098)"
3. Additional 7-pin socket is mounted to connect the EBS system of the (semi-)trailer
 1. EBS connector A004; see section 12.20: "Connector A004 trailer system (ISO7638)"
4. 12V/40A electric trailer connection (Vehicles for application class 2A. Not in combination with anti-theft systems)
 1. 12V connector (connector code is A019).

BODYBUILDERS' GUIDELINES

Electrical system CF series

10.16 CF75 - CF85 ESC SYSTEM

CF75 - CF Series ESC control.



NOTE: Following information, except the PR engine related data, is also valid for the XF Series.

Applicable selection codes:

Selco codes	description
0761	without engine speed control connector (a) + b
0797	with engine speed control cab connector a + b
9231	with engine speed control chassis connector a + b + c
9560	without body builder CAN/without CANopen
9562	with application connector body builder CAN a + d + e + f

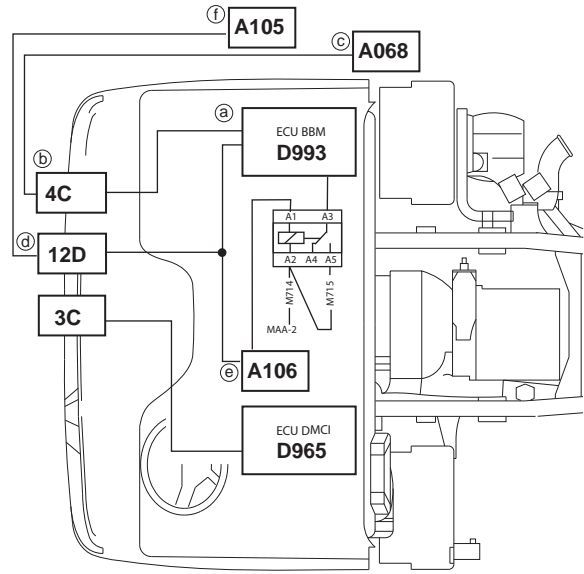

G001186



*NOTE: Connector 4C is always present due to standardisation. If selco 0797 is selected, the corresponding functionality is also present (correct BBM software).
For part numbers of the bulkhead connectors check chapter 13.4: "Electric connector parts cabine (CF75-85 and XF Series)".*

Applicable application connectors in cab and chassis depending on selection code:

Connector Codes	See the sections indicated below for additional information on pinning and wire numbers in the connectors used.
A068	section: 12.26: "Connector A068 (chassis - ESC system)"
A105	section: 12.37: "Connector A105 Bodybuilder CAN system 7-pole"
A106	section: 12.38: "Connector A106 CAN-cab 9-pole"
4C	section:12.6: "Connector 4C ESC system"
12D	section:12.11: "Connector 12D body builder"

Purpose of the function

The purpose of the engine speed control system is to enable the engine speed to be adjusted between idling speed and the maximum speed. This adjustable engine speed is used, among other things, to drive auxiliary consumers via a

PTO. The engine speed control can be used while driving or when idling by setting the correct customer parameters using DAVIE. The engine speed control can be enabled by the driver using the steering wheel switches, steering column switches or, if the correct selection codes have been chosen, through the superstructure equipment via the relevant application connector (A068 hardwired and A105 CAN). Enabling the engine speed control via one of the application connectors takes priority over the steering column switches.

Schematic overview of ESC system control

The diagram below provides a schematic overview of the engine speed control. The two main groups for controlling the engine speed control can be identified as follows:

1. Enabling engine speed control by the driver via the VIC (Vehicle Intelligence Centre)
 - Steering wheel switches
 - Steering column switch
2. Enabling engine speed control by the body via the BBM (Body Builder Module)
 - Cab application connector
 - Chassis application connector

BODYBUILDERS' GUIDELINES

Electrical system CF series

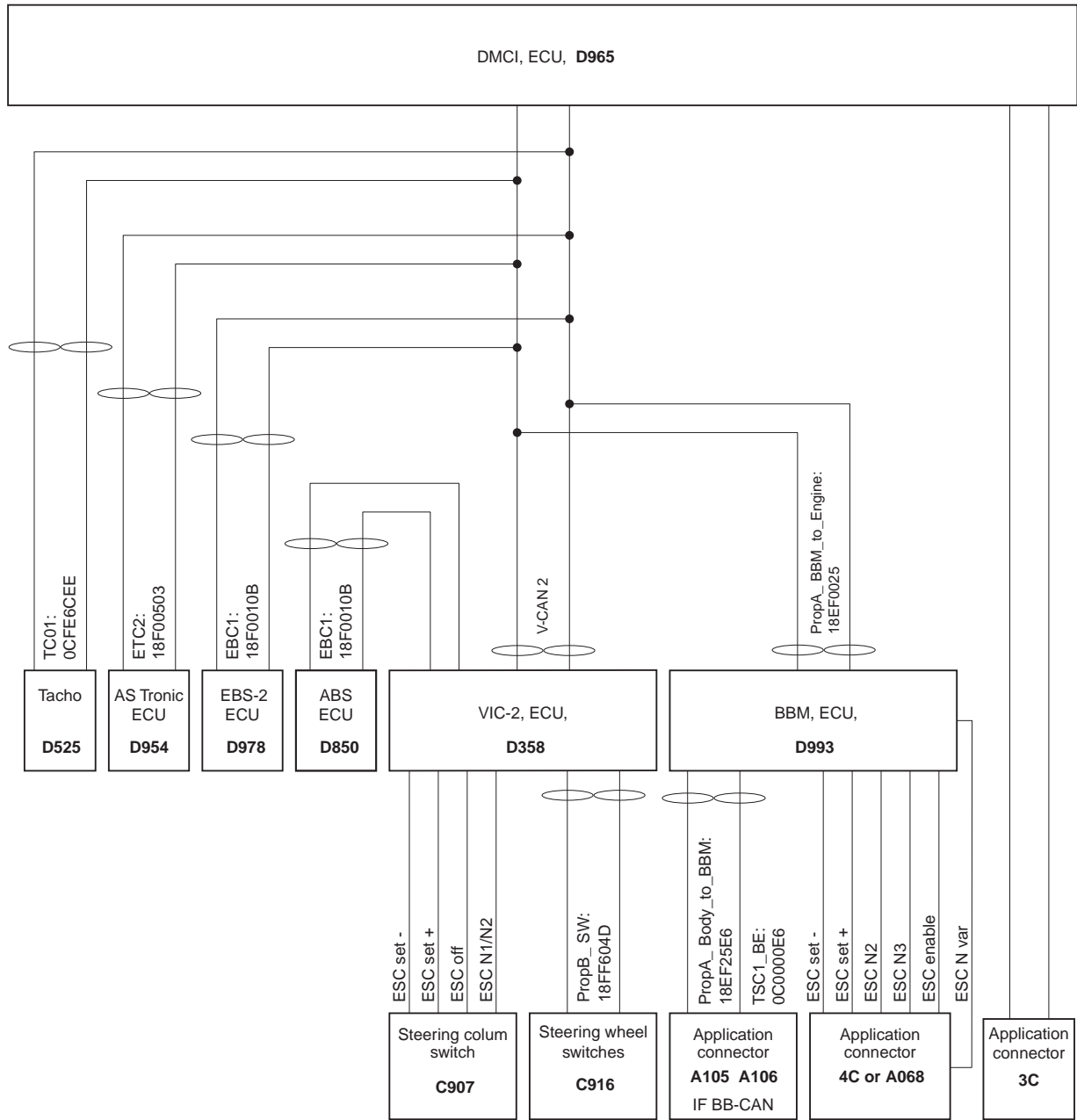

G001187

General ESC control system layout

CAN signal description				
CAN Message name	Message id	Used CAN Signals for ESC ⁽¹⁾	Startbit	Length
TC01	0CFE6CEE	Tachograph vehicle speed	48	16
PropB_SW	18FF604D	Cruise control resume switch	16	2
		Cruise control off switch	18	2
		Cruise control accelerate switch	20	2
		Cruise control coast switch	22	2
CCVS	18FEF100	Parking brake switch	2	2
		Cruise control active	24	2
		Cruise control enable switch	26	2
		Brake switch	28	2
		Clutch switch	30	2
		Cruise control set switch	32	2
		Cruise control coast switch	34	2
		Cruise control resume switch	36	2
		Cruise control accelerate switch	38	2
		Cruise control set speed	40	2
Cruise control state	53	2		
EBC1	18F0010B	EBS brake switch	6	2
ETC2	18F00503	Selected gear	0	8
PropA_BBM_to_Engine	18EF0025	Engine requested torque/torque limit	8	8
		Engine requested speed/speed conditions	16	16
		Engine override control mode	32	2
		Engine requested speed control conditions	34	2
		ESC enable	48	2
		ESC set minus	50	2
		ESC N variable	52	2
		ESC set plus	54	2
		Application speed limiter switch	56	2
		ESC N2	58	2
		ESC N3	60	2
		Engine stop	62	2
TSC1_BE	0C0000E6	Override control modes	0	2
		Requested speed control condition	2	2
		Override control mode priority	4	2
		Requested speed speed limit	8	16
		Requested torque torque limit	24	8

BODYBUILDERS' GUIDELINES

Electrical system CF series

CAN signal description				
CAN Message name	Message id	Used CAN Signals for ESC ⁽¹⁾	Startbit	Length
PropA_body_to_BBM	18EF25E6	Engine requested torque/torque limit	8	8
		Engine requested speed/speed limit	16	16
		Engine override control mode	32	2
		Engine requested speed control conditions	34	2
		Engine start	42	2
		ESC enable	48	2
		ESC set minus	50	2
		ESC n variable	52	2
		ESC set plus	54	2
		Application speed limiter switch	56	2
		ESC N2	58	2
		ESC N3	60	2
		Engine stop	62	2

(1) only ESC related messages are shown.

Enabling engine speed control by the driver

As is evident from the schematic overview, the VIC can receive the engine speed control signals from the steering wheel switches (via CAN) or via the steering column switch (hardwired). The VIC translates these signals into a CAN message, which is sent to the engine control unit.

The steering column switches and the steering wheel switches have the same engine speed control operating functions, namely: "SET+", "SET-", "N1", "N2" and "OFF".

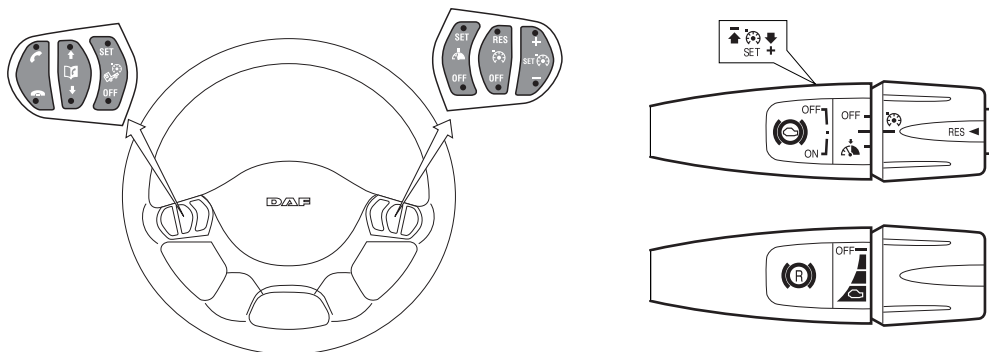

Steering wheel and stalk lever switches

G000391

Operating functions of the steering column and steering wheel switches		
Function	Standard setting	Choices in DMCI via DAVIE (CP = customer parameter)
SET + SET -	Operating "SET+/-" switches the engine speed control on and sets the current engine speed as the desired speed (constant value).	
	Brief operation ⁽¹⁾ of "SET +/-" during ESC gives a stepped increase or reduction of engine speed (default 25 rpm)	0<step<400 [rpm] CP2-20 and CP2-38
	Long operation ⁽²⁾ of "SET +/-" during engine speed control gives a continuous increase or reduction of the preset desired speed (default 200 rpm/s).	0<ramp<400 [rpm/s] CP2-18 and 2-19
	When "SET +/-" is released, the current engine speed is set as the new desired engine speed	
	The desired engine speed can be varied using "set +/-" between minimum (N_min = idling) and the maximum speed to be set.	N_idling<speed limit<N_max (rpm) via CP2-15 and CP2-14
N1	Operating "N1" activates the engine speed control and sets the engine speed to the value entered using CP2-16 (default 800 rpm). Activation using "RES" (resume) button.	To be set using CP2-16 between the values set using CP2-15 and CP2-14
N2	Operating "N2" activates the engine speed control and sets the engine speed to the value entered using CP2-17 (default 1200 rpm). Activation by operating "RES" (resume) button twice. With this "RES" button the operator can toggle between N1 and N2.	To be set using CP2-17 between the values set using CP2-15 and CP2-14
OFF	Engine speed control is switched off using the "OFF" button.	

(1) Brief operation: touch time < 0.3 s

(2) Long operation: touch time > 0.3 s

To make engine speed control possible, a number of (default) cut-in conditions must be met, namely:

- The handbrake must be engaged. (CP2-32)
- The vehicle speed must not be faster than 10 km/h. (CP2-11)
- Clutch pedal is not operated. (CP2-34)
- Brake pedal is not operated. (CP2-33)
- Engine brake foot pedal is not operated. (no CP)

In addition, there are a number of faults that can be checked, which, if active, prevent the engine speed control from being activated.

- No faults are active that relate to vehicle speed.
- No faults are active that relate to Set+/Set-plausibility
- No faults are active that relate to engine speed.

BODYBUILDERS' GUIDELINES

Electrical system CF series

- No faults are active that relate to CAN communication.
- No faults are active that relate to clutch signal plausibility.
- No faults are active that relate to handbrake signal.
- No faults are active that relate to clutch signal.
- No faults are active that relate to a neutral gearbox signal.

If, for the body function, it is necessary to deviate from the standard options tested and released by DAF, DAF shall no longer be responsible for the operation. The implementation of non-standard body functions and the possible consequences are the responsibility of the user (generally the bodybuilder), who then bears product liability.

If the above conditions are met, the application connector can be used in various ways to activate the engine speed control, namely via:

	Hardwired or CAN	Activation	Priority ⁽¹⁾
Application connector	Hardwired	ESC enable	1
PropA_Body_to_BBM	CAN	ESC enable and Engine override control mode	2
TSC1_BE (torque/speed limitation)	CAN	ESC enable and Engine override control mode	3

(1) If a unit is active and a unit with a higher priority is activated, the unit with the highest priority will become active immediately. Only one unit of the above variations can be active, so no combination of various units is possible.

The above table indicates that hardwired activation has the highest priority followed by activation via CAN. It is important to note that the choice between the PropA_Body_to_BBM and TSC1_BE message depends on the activation of the engine speed control in the PropA_Body_to_BBM message. If the engine speed control is active via bit 1 and 2 of byte 7 from this message, the PropA_Body_to_BBM message is the determining factor. If bit 1 and 2 of byte 7 are not equal to active, then the TSC1_BE message is, providing bit 1 and 2 of byte 1 are not equal to "0". This is clarified in the table below.

Input			Output
Engine speed control activation via pin 7 application connector 4C or A068	Engine speed control activation via bit 1 and 2 of byte 7 from the PropA_Body_to_BBM message.	Engine override control mode activation via bit 1 and 2 of byte 1 from the TSC1_BE message.	
Active	No influence	No influence	Application connector
Not active	Active	No influence	PropA_Body_to_BBM
Not active	Not active	$\neq 00_b^{(2)}$	TSC_BE
Not active	$\neq \text{Active}^{(1)}$	$00_b^{(2)}$	No limitation

(1) \neq Active = Inactive, Error, Not available or Time-out
 (2) 00_b = 00 binaire

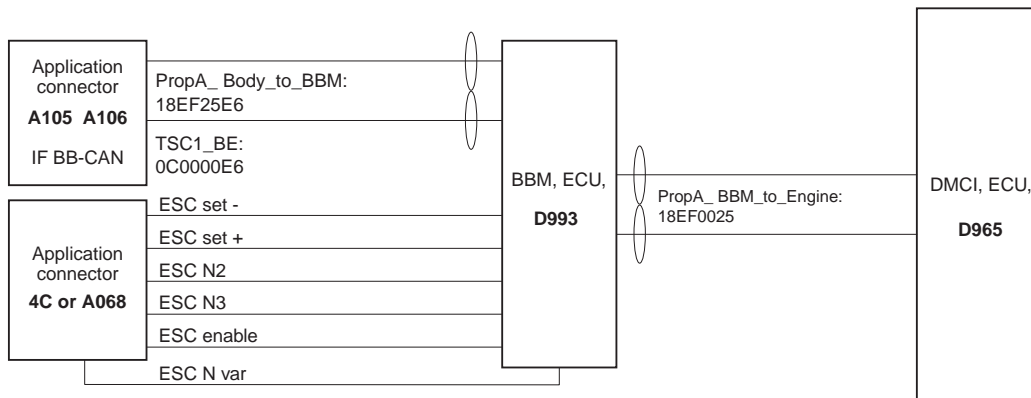

G001173

Schematic overview of ESC system control via the body

Hardwired activation of engine speed control

For operating the engine speed control through the body connection (see relevant selcos), the same functions, cut-in and cut-out conditions, and customer choices are offered as for the engine speed control through the steering column switch. The functions "SET+" and "SET-" are controlled using pulse and continuous signals. Via the hardwired input on the application connector, two engine speeds N2 or N3 that are to be pre-programmed and a variable engine speed (Nvar) are also to be activated. To activate these speeds the engine speed control must first be enabled by providing a high signal on pin 7 of cab connector 4C or chassis connector A068. Then N2 and N3 can be activated by providing a high signal on pins 10 and 11 respectively of this connector, and if a high signal is provided on pin 8 of the above connectors, Nvar is activated.

BODYBUILDERS' GUIDELINES

Electrical system CF series



WARNING! For safety reasons it is not permitted to activate the "enable" via a through connection at the same time as N2, N3 or Nvar. If two separate connections are not used it will not be possible to switch off the engine speed control if a short circuit occurs.

Operating functions of the application connector (4C or A068)		
Function ⁽¹⁾	Standard setting	Choice in DMCI via DAVIE (CP = customer parameter)
Enable ESC	If the engine speed control function is activated and the vehicle speed is lower than the limiting speed for engine speed control + 5 km/h, the engine speed control is enabled through the body connection. At the same time, operation via the steering column switch is blocked.	
SET + SET - Pulsing or continuous ⁽²⁾	Operating "SET+/-" switches the engine speed control on and sets the current engine speed as the desired speed (constant value).	
	Brief operation ⁽³⁾ of "SET +/-" during engine speed control gives a stepped increase or reduction of the engine speed (default 25 rpm).	0<step<400 [rpm] via CP2-20 and CP2-38
	Long operation ⁽⁴⁾ of "SET +/-" during engine speed control gives a continuous increase or reduction of the preset desired speed (default 200 rpm/s).	0<ramp<400 [rpm/s] via CP2-18 and 2-19
	When "SET+/-" is released, the current engine speed is set as the new desired engine speed	
	The desired engine speed can be varied using "SET +/-" between the minimum and the maximum speed to be set.	N_idling<speed limit<Nmax (rpm) via CP2-15 and CP2-14
N_variable	Operating "Enable N_variable" activates the engine speed control and sets the last desired engine speed set using SET+ and SET-. This value is also memorised when the ignition is switched off. Varying the desired speed is possible using SET+/- but only if the input "Enable N_variable" is activated.	
N_2	Operating "N2" activates the engine speed control and sets the engine speed to the value entered using CP2-16 (default 800 rpm).	To be set using CP2-28 between the values set using CP2-15 and CP2-14
N_3	Operating "N3" activates the engine speed control and sets the engine speed to the value entered using CP2-17 (default 1200 rpm).	To be set using CP2-29 between the values set using CP2-15 and CP2-14
V_max application ⁽⁵⁾	If the Vmax application input is activated by providing a high signal, the vehicle speed is limited to the pre-programmed value (default 30 km/h).	Adjustable using CP2-10 between a value of 0 and 30 km/h
Engine speed	Output signal, square-wave, 30 pulses per revolution; LS pulse	
Engine stop	Control signal (24 V) for starting the engine remotely.	Option must be activated using CP1-87. Value must be set between 1 and 30 km/h.
Engine start	Control signal (24 V) for switching off the engine remotely.	Option must be activated using CP1-86.

(1) If operated simultaneously, the priority is as follows (high to low): "enable ESC", "N2", "N3", N_variable (SET+/-).

(2) Pulse signal = a signal becomes a pulse when the rising edge reaches a value of 0.6 x U_bat. Continuous signal is "high" at a voltage level of 0.6 x U_bat and "low" if below a level of 0.4 x U_bat.

(3) Brief operation: touch time < 0.3 s (default).

BODYBUILDERS' GUIDELINES

Electrical system CF series

- (4) Long operation: touch time > 0.3 s (default).
 (5) Special applications (e.g. refuse vehicles).

Activation of engine speed control via CAN message PropA_Body_to_BBM

In addition to calling up two, pre-set target speeds via the hardwired option, it is also possible, providing selection code 9562 "with application connector body builder CAN" has been chosen, to activate these target speeds via CAN. To be able to use this functionality, the body must provide CAN message PropA_Body_to_BBM with identifier 18_EF_25_E6 to pin 17 and 18 of connector 12D. The data that must be provided in this message is as follows:

Signal name	Byte	Bit	Type	Offset	Min	Max	Unit	Comments
ESC enable	7	2,1	Status	-	0	3	-	00 _b =passive 10 _b =error 01 _b =active 11 _b =not available
ESC set min	7	4,3	Status	-	0	3	-	00 _b =passive 10 _b =error 01 _b =active 11 _b =not available
ESC N variable	7	6,5	Status	-	0	3	-	00 _b =passive 10 _b =error 01 _b =active 11 _b =not available
ESC set plus	7	8,7	Status	-	0	3	-	00 _b =passive 10 _b =error 01 _b =active 11 _b =not available
ESC N2	8	4,3	Status	-	0	3	-	00 _b =passive 10 _b =error 01 _b =active 11 _b =not available
ESC N3	8	6,5	Status	-	0	3	-	00 _b =passive 10 _b =error 01 _b =active 11 _b =not available
Engine requested Speed Control Conditions	5	4,3	Status	-	0		-	00 _b =override disabled 01 _b =Speed control 10 _b =Torque control 11 _b =Speed/Torque limit control

10

BODYBUILDERS' GUIDELINES

Electrical system CF series

Signal name	Byte	Bit	Type	Offset	Min	Max	Unit	Comments
Engine Override Control mode	5	-2,1	Status	-	0	3	-	00 _b =Transient optimized for driveline disengaged and non-lockup conditions 01 _b = Stability optimized for driveline disengaged and non-lockup conditions 10 _b = Stability optimized for driveline engaged and/or in lockup condition 1 11 _b = Stability optimized for driveline engaged and/or in lockup condition 2
Engine requested Speed/ Speed limit	4,3		Value	-	0	803 1,87 5	Rpm	
Engine requested Torque/ Torque limit	2		Value	-125	-125	125	%	

In message PropA_Body_to_BBM the commands that are provided through the hardwired option may also be provided via CAN, as is evident from the table. In addition, contrary to earlier releases, a torque/speed limit can be forced via this message by selecting the correct CAN configuration of the message provided. This function makes it possible to select any speed between the limits defined using customer parameters (2-14 and 2-15) via the Body Builder CAN.

By way of clarification, an example of the content of the PropA_Body_to_BBM message is given below.

PropA_Body_to_BBM (18 EF 25 E6)												
Name	Source	Destination	Direction	DataLength Code	DATA: 01 00 E2 04 F4 F7 41 04							
PropA_Body_to_BBM	E6	5	X	8	Byte 1	Byte 2	Byte 3	Byte 4	Byte 5	Byte 6	Byte 7	Byte 8
					01	00	E2	04	F4	F7	41	04

10

BODYBUILDERS' GUIDELINES

Electrical system CF series

Signal	Physical value	Byte/bit number	(b) = Binair (h) = Hexagonal value	Comment
Requested_Torque_Torque_limit	-125%	Byte 2	00(h) 0000 000(b)	Physical value = (CAN data x rise/scale) + offset = (0 x 1/1) + (-125) = -125%
Requested_Speed_Speed_limit	1250 rpm	Byte 4,3	04 E2(h) 0000 0100 1110 0010(b)	Physical value = (CAN data x rise/scale) + offset = (1250 x 1/1) + 0 = 1250 rpm
Requested_Speed_Control_Condition	01 _b = Speed control	Byte 5 bit 4,3	F4(h) 1111 0100(b)	(01)
Override_Control_Mode	00 _b =Transient optimized for driveline disengaged and non-lockup conditions	Byte 5 bit 2,1	F4(h) 1111 0000(b)	(00)
ESCn3	00 _b =passive	Byte 8 bit 6,5	04(h) 0000 0100(b)	(00)
ESCn2	01 _b =active	Byte 8 bit 4,3	04(h) 0000 0100(b)	(01)
ESCn_variable	00 _b =passive	Byte 7 bit 6,5	41(h) 0100 0001(b)	(00)
ESC_set_plus	01 _b =active	Byte 7 bit 8,7	41(h) 0100 0001(b)	(01)
ESC_set_minus	00 _b =passive	Byte 7 bit 4,3	41(h) 0100 0001(b)	(00)
ESC_enable	01 _b =active	Byte 7 bit 2,1	41(h) 0100 0001(b)	(01)
Engine_stop	00 _b =passive	Byte 8 bit 8,7	04(h) 0000 0100(b)	(00)
Engine_start	01 _b =active	Byte 6 bit 4,3	F7(h) 1111 0111(b)	(01)
Application_speed_limiter	00 _b =passive	Byte 8 bit 2,1	04(h) 0000 0100(b)	(00)

Activating engine speed control via CAN message TSC1_BE.

In addition to calling up two, pre-set target speeds via the hardwired option, it is possible, providing selection code 9562 "with application connector body builder CAN" has been chosen, to select any speed between the limits defined using client parameters (2-14 and 2-15) via the Body Builder CAN. To be able to use this function, the body must provide a Torque/Speed Control message on pin 17 and 18 of connector 12D. In this torque speed control message, any desired speed and/or torque limit can be selected by filling in the message content correctly. The signals sent by the body are translated by the BBM and are part of the PropA_BBM_to_Engine message. This

message is one of the TSC messages that the ECU engine can receive, although with a much lower priority. Identifier = 0C 00 00 E6 to be programmed and the content of the message is as follows:

Signal name	Byte	Bit	Type	Offset	Min	Max	Unit	Comments
Engine requested Speed Control Conditions	1	4,3	Status	-	0	3	-	00 _b = override disabled 01 _b = Speed control 10 _b = Torque control 11 _b = Speed/Torque limit control
Engine Override Control mode	1	2,1	Status	-	0	3	-	00 _b = Transient optimized for driveline disengaged and non-lockup conditions 01 _b = Stability optimized for driveline disengaged and non-lockup conditions 10 _b = Stability optimized for driveline engaged and/or in lockup condition 1 11 _b = Stability optimized for driveline engaged and/or in lockup condition 2
Engine requested Speed/ Speed limit	3,2	All	Value	-	0	8031,875	Rpm	
Engine requested Torque/ Torque limit	4	All	Value	-125	-125	125	%	

By way of clarification, an example of the content of the TSC1_BE (0C 00 00 E6) message is given below.

TSC1_BE (0C 00 00 E6)												
Name	Source	Destination	Direction	Data Length Code	DATA: 5A 00 E0 2E DD FF FF FF							
TSC1_BE	E6	00	RX	8	Byte 1	Byte 2	Byte 3	Byte 4	Byte 5	Byte 6	Byte 7	Byte 8
					5A	DC	05	DD	FF	FF	FF	FF

By way of clarification, an example of the content of the TSC1_BE (0C 00 00 E6) message is given below.

BODYBUILDERS' GUIDELINES

Electrical system CF series

Signal	Physical value	Byte / bit number	(b) = Binair (h) = Hexagonal value	Comment
Requested_Torque_Torque_limit	96%	Byte 4	DD(h) 1101 1101(b)	Physical value = (CAN data x rise/scale) + offset = (221 x 1/1) + (-125) = 96%
Requested_Speed_Speed_limit	1500 rpm	Byte 3,2	05 DC(h) 0000 0101 1101 1100(b)	Physical value = (CAN data x rise/scale) + offset = (1500 x 1/1) + 0 = 1500 rpm
Requested_Speed_Control_Condition	10 _b = Torque control	Byte 1 bit 4,3	5A(h) 0101 1010(b)	(10)
Override_Control_Mode	10 _b = Stability optimized for driveline engaged and/or in lockup condition 1	Byte 1 bit 2,1	5A(h) 0101 1010(b)	(10)

Irrespective of the way in which the engine speed control is activated (via CAN or hardwired), a torque limit can be activated during engine speed control. The various limits are set if a combination is made with wires 6185 and 6186, pin 3 and 6 respectively in bulkhead connector 3C. These limits are necessary as in many cases engine speed control is used in combination with an auxiliary consumer (PTO). This auxiliary consumer has certain limitations, which naturally must not be exceeded and the torque and speed limits are required for that purpose. By using customer parameter 2-30 the accelerator pedal can be switched off during ESC operation. When the accelerator pedal is switched on, the preset value of the engine speed control can be overruled up to the maximum allowed speed during engine speed control using customer parameter 2.31.

Coupling the PTO activation signal to wire 6185 and/or 6186 will limit the engine speed during PTO usage and a torque limitation applies when engine speed control is active and a fixed % of the original torque curve when the engine speed control is not active.

The combinations and corresponding limitations are given in the table below.

Wire 6185 Connector 3C Pin 3	Wire 6186 Connector 3C pin 6	ESC active Engine speed maximised by ESC_N_max (CP2-14) ⁽²⁾		Driving mode ⁽¹⁾ Engine speed maximised by N_max ⁽³⁾	
		PR engine	MX engine	PR engine	MX engine
0 Volt	0 Volt	No limitation		No limitation	
24 Volt	0 Volt	1000 Nm	1800 Nm	95%	
0 Volt	24 Volt	750 Nm	1200 Nm	80%	
24 Volt	24 Volt	500 Nm	600 Nm	60%	

(1) The limitation in driving mode can be used irrespective of whether engine speed control is enabled or not.

(2) As absolute maximum engine torque.

(3) Limitation can be changed by cp.



NOTE: An intermediate level of torque limitation (up to 70% of maximum torque) during ESC operation can be set using customer parameter 2-37. Parameter 2-37 allows automatic torque limitation during engine speed control operation only. The limitation level is a percentage of maximum torque, and therefore engine configuration dependant. Given the above information we can provide hardwired torque limitation as well as via CAN. The hardwired limitation has the highest priority. If, in addition, the hardwired option and the automatic option are activated, the lowest value will be used as limitation value.

In addition to various cut-in conditions, the cut-out conditions must also be taken into account. These cut-out conditions are:

- The handbrake must be disengaged. (CP2-32)
- The vehicle speed is higher than limit value + offset (10+5=15 km/h). (CP2-11)
- Clutch pedal is operated. (CP2-34)
- Brake pedal is operated. (CP2-33)
- Engine brake foot pedal is operated. (no CP)

In addition, there are a number of faults that are checked and if active, the engine speed control should be switched off:

- A vehicle speed fault is active.
- A plausibility fault is active on the set+/set-switches.
- An engine speed fault is active.
- A fault that relates to the CAN communication is active.
- A plausibility fault is active that relates to the clutch signal.
- A fault is active that relates to the handbrake signal.

BODYBUILDERS' GUIDELINES

Electrical system CF series

- A fault is active that relates to the clutch signal.
- A fault is active that relates to the neutral signal of the gearbox.

In addition to the cut-in and cut-out conditions, the system also has a number of overrule conditions. An overrule condition means that the control under which the system is operating at that point is temporarily suppressed. These overrule conditions are:

- Accelerator pedal operation. (CP 2-30)
The accelerator pedal can be used to temporarily increase the engine speed up to a maximum value preset under customer parameter 2.14 (max. ESC speed).
- Exceeding vehicle speed limit. (CP 2-11)
- ASR activation.
- Speed limiter activation.

Customer ⁽¹⁾ parameter ID	Customer parameter name	System	Value
	ENGINE SPEED CONTROL		
2-14	MAX ESC SPEED.	DMCI	Rpm
2-15	MIN ESC SPEED	DMCI	Rpm
2-18	ACCELERATION RAMP CONTINUOUS UP ESC	DMCI	Rpm/s
2-19	ACCELERATION RAMP CONTINUOUS DOWN ESC	DMCI	Rpm/s
2-20	ACCELERATE UP PER TIP	DMCI	Rpm/tip
2-38	DECELERATE DOWN PER TIP	DMCI	Rpm/tip
2-22	ACCELERATE FROM IDLE TO TARGET SPEED IN ESC	DMCI	Rpm/s
2-39	DECELERATE FROM TARGET SPEED IN ESC TO IDLE	DMCI	Rpm/s
2-27	ESC CHANGE STEERING COLUMN N VARIABLE	DMCI	Rpm
2-16	ESC CAB N1	DMCI	Rpm
2-17	ESC CAB N2	DMCI	Rpm
2-28	ESC CHANGE APPLICATION CONN. N2	DMCI	Rpm
2-29	ESC CHANGE APPLICATION CONN. N3	DMCI	Rpm

(1) For changing default parameter settings see chapter 7.19: "Guideline for the Customer Parameter Change Form"

Customer (1) parameter ID	Customer paramer name	System	Value
	ENGINE SPEED CONTROL CONDI- TIONS		
2-30	ACCEL. PEDAL	DMCI	ACTIVE/NOT ACTIVE
2-31	MAX RPM ACCELERATOR PEDAL	DMCI	Rpm
2-32	PARK BRAKE	DMCI	ACTIVE/NOT ACTIVE
2-33	BRAKE	DMCI	ACTIVE/NOT ACTIVE
2-34	CLUTCH	DMCI	ACTIVE/NOT ACTIVE

(1) For changing default parameter settings see chapter 7.19: "Guideline for the Customer Parameter Change Form"

Customer (1) parameter ID	Customer paramer name	System	Value
	LIMITERS		
2-46	CUSTOM ENGINE SPEED LIMIT 1	DMCI	Rpm
2-41	CUSTOM ENGINE SPEED LIMIT 2	DMCI	Rpm
2-42	CUSTOM ENGINE SPEED LIMIT 3	DMCI	Rpm

(1) For changing default parameter settings see chapter 7.19: "Guideline for the Customer Parameter Change Form"

10.17 CF75 - 85 SERIES FMS / DTS SYSTEM

CF series FMS / DTS system



NOTE: Following information is also valid for the XF series.

BODYBUILDERS' GUIDELINES

Electrical system CF series

Applicable selection codes:

- 8360: without Fleet Management System
- 6407: with Fleet Management System preparation
- 9990: with DAF Telematics System preparation
- 1075: with DAF Telematics System

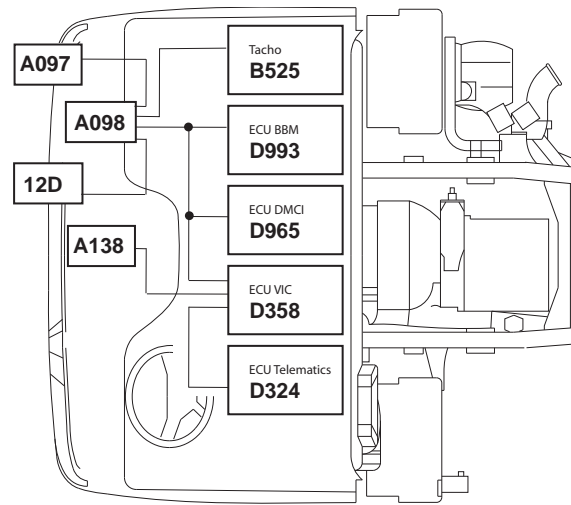

G001169

Applicable FMS application connectors cabine:

Connector Codes	See the sections indicated below for additional information
A097	section: 12.31: "Connector A097 FMS system"
A098	section: 12.32: "Connector A098 FMS system"
A138	section: 12.46: "Connector A138 FMS 12-pole"

Purpose of the function

FMS stands for **F**leet **M**anagement **S**ystem and is used to provide information about condition of the vehicle to the fleet owner for logistic purposes. The (wireless) transmission of the data from vehicle to user is performed by a third party ECU which will get the data provided by the VIC-2 via de D-CAN interface.

The main vehicle manufacturers, including DAF, have together agreed on the data to be universally provided for these FMS systems via the CAN link. Third parties are able to connect and to get the data from the truck CAN bus system. This document describes which D-CAN messages will to be supported via the FMS prepared selco 6407 or the DTS (DAF Telematics System) prepared selco 9990.

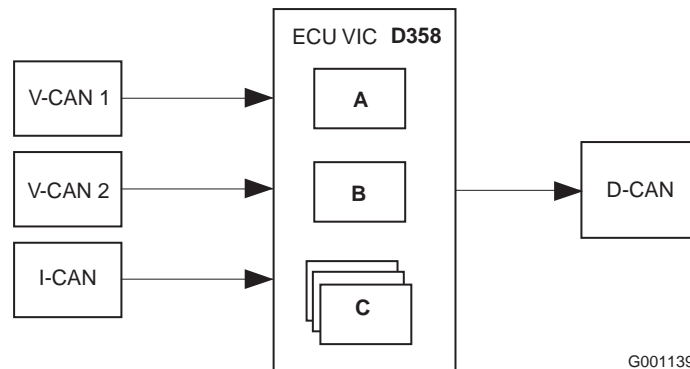

- A D-CAN gateway for FMS standard messages
- B D-CAN gateway for additional DTS messages
- C PLC functions

From week 2008-13 in total three connectors are available for connecting to the D-CAN bus were the FMS messages will be broadcasted. One of these three connectors is the standardised 12-pins FMS connector and is called A138.

A Fleet Management System needs some specific information to know which CAN-data is available and how to handle this CAN-data. This information is send in the CAN-message "FMS standard software version supported". This CAN-message is accepted by SAE J1939. Before there was no standard CAN-message and DAF would send the CAN-message "FMS standard information".

The following table describes the amount of data which will be send by DAF on the D-CAN for FMS preparation and DTS preparation.

BODYBUILDERS' GUIDELINES

Electrical system CF series

Message	Message ID ⁽²⁾	Repetition Rate (ms)	FMS Prepared Selco 6407	DTS Prepared Selco 9990
EEC2	0C F0 03 00	50	X	X
EEC1	0C F0 04 00	20	X	X
Engine hours revolution	18 FE E5 00	On request	X	X
Vehicle Identification	18 FE EC EE	On request	X	X
High Resolution Vehicle Distance	18 FE C1 EE	1000	X	X
TC01	0C FE 6C EE	50	X	X
Engine temperature	18 FE EE 00	1000	X	X
Fuel economy	18 FE F2 00	100	X	X
Service	18 FE C0 27	1000	X	X
Vehicle weight	18 FE EA 27	1000	X	X
Dash display	18 FE FC 27	1000	X	X
FMS standard interface	1C FD D1 27	10000	X	X
CCVS	18 FE F1 00	100	X	X
Fuel consumption	18 FE E9 00	1000	X	X
DM1	18 FE CA XX	1000 ⁽¹⁾		X
TP_DT (BAM)	1C EB FF XX	-		X
TP_CM	1C EC FF XX	-		X
DM1 VIC	18 FE CA 27	1000 ⁽¹⁾		X
TP_DT (BAM)	1C EB FF XX	-		X
TP_CM	1C EC FF XX	-		X
PropB_BBM	18 FF 82 25	250		X
ERC1_XR	18 F0 00 29	100		X
ERC1_DR	18 F0 00 10	100		X
EBC1	18 F0 01 0B	100		X
Tire condition (truck)	18 FE F4 33	500		X
Tire condition (trailer)	18 FE F4 C8	500		X
EBS23	18 FE C6 C8	100		X
RGE23	18 FE 5E C8	1000		X
EBS22	18 FE C4 C8	100		X
RGE22	18 FE 5C C8	100		X
Ambient conditions	18 FE F5 00	1000		X
Inlet / exhaust conditions	18 FE F6 00	500		X
Engine fluid level pressure	18 FE EF 00	500		X
Time date	18 FE E6 EE	1000		X
PropB_EST42	18 FF 40 10	100		X
Tank information #1	18 FE 56 3D	1000		X
Driver information	18 FE 6B EE	On request		X
Combination vehicle weight	18 FE 70 0B	On request		X

BODYBUILDERS' GUIDELINES

Electrical system CF series

Message	Message ID ⁽²⁾	Repetition Rate (ms)	FMS Prepared Selco 6407	DTS Prepared Selco 9990
ETC2	18 F0 05 03	100		X
Operator wiper and washer controls	18 FD CD 27	100		X
Operator external Light controls	18 FD CC 27	100		X
Cab illumination	18 D0 FF 27	5000		X
Vehicle hours	18 FE EC 27	1000		X

(1) Repetition rate when DM1 is active.

(2) For detailed message content see equivalent documents ("FMS CAN message overview.pdf" or "DTS CAN message overview.pdf") on the information sheet web page. (The Internet URL for the corporate DAF website is: www.daf.com -> follow the main menu item: "Products" -> Bodybuilder guidelines webpage -> Information Sheet webpage)

Terminator resistor D-CAN

FMS and DTS prepared are connected at the end of the D-CAN bus and therefore a terminator resistor is required. Vehicles with FMS prepared are ex-factory equipped with a terminator resistor in connector A098 on pin 10 and 11. Depending on the connected FMS system (with or without internally terminator resistor) one terminator resistor has to be fitted at the end of the D-CAN bus. In the table below the different situations are described.

	Terminator resistor in A098 ⁽¹⁾	Terminator resistor in A138 ⁽¹⁾
No FMS system connected	Yes	No
FMS with internal terminator resistor	No	No
FMS connected to A098 without terminator resistor	No	Yes
FMS connected to A138 without terminator resistor	Yes	No

(1) If the terminator resistor is mounted in connector A098, wire length of the FMS system connected to connector A138 is limited to 95cm. To be able to use more wire length the connected FMS system should have an internal terminator resistor and together the original terminator resistor has to be removed out of connector A098.

10.18 CF SERIES PTO CONTROL / PROTECTION

CF75 - CF85 Series PTO-control

10

BODYBUILDERS' GUIDELINES

Electrical system CF series

Applicable selection codes:

Selco codes	description
4610	without engine PTO
9181	with engine PTO / without control
9581	with engine PTO / with control

Selco codes	description
1412	without gearbox PTO-1 / without control
1118	with gearbox PTO-1 / without control
various	with gearbox PTO / with control

Selco codes	description
4852	without gearbox PTO-2 / without control
various	with gearbox PTO-2 / with control

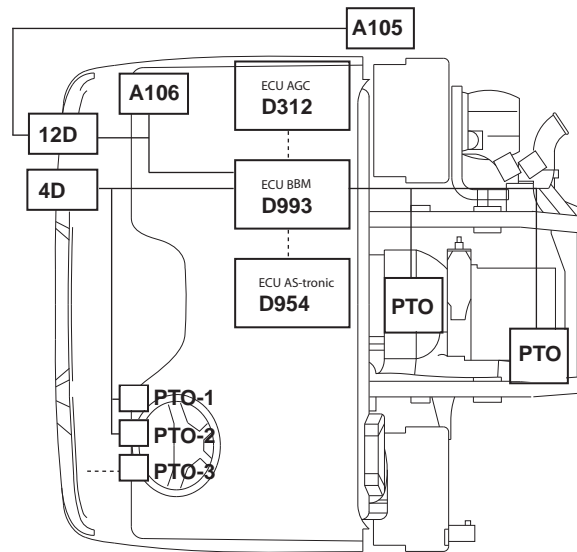

G001195

Applicable application connectors in cab and chassis depending on selection code:

Connector Codes	See the sections indicated below for additional information on pinning and wire numbers in the connectors used.
A105	section: 12.37: "Connector A105 Bodybuilder CAN system 7-pole"
A106	section: 12.38: "Connector A106 CAN-cab 9-pole"
4D	section:12.7: "Connector 4D PTO control system"
12D	section:12.11: "Connector 12D body builder"

Purpose of the function

A PTO (power take off) enables a body builder or customer to derive mechanical energy from the vehicle to activate special functions, e.g. pumps. A PTO can be switched on by activating an EP valve. The driver can request activation of the PTO by activating a PTO switch. Before activating the PTO the BBM will check if the switch-on conditions are met. Also the PTO will be disabled if, with an activated PTO, one of the switch-off conditions are met. The switch on and off conditions can be adjusted by the DAF dealer via DAVIE. Up to two PTO's can be controlled by the Body Builder Module.

The main purpose of the PTO control system is to engage the PTO under safe conditions. The PTO can be used while driving or when idling by setting the correct customer parameters using DAVIE.

PTO configuration for vehicles with a manual gearbox.

PTO-1	PTO-2
Engine PTO	
Engine PTO	Gearbox PTO N1/ N4 ⁽¹⁾
Engine PTO	Gearbox PTO N10 ⁽¹⁾
-	Gearbox PTO N10 ⁽¹⁾
Gearbox PTO N1/N4 ⁽¹⁾	Gearbox PTO N10 ⁽¹⁾
Gearbox PTO N1/N4 ⁽¹⁾	

(1) In the BBM software no difference is made between N1, N4 or N10 PTO.

Schematic overview of PTO control

The diagram below provides a schematic overview of the PTO control. The two main groups for controlling the PTO can be identified as follows:

1. Enabling PTO control by the driver via the dashboard switches.
2. Enabling PTO control by the body via hardware connections (connector 4D) or via CAN.
 - Cab application connector (hard wired)
 - Chassis application connector (CAN controlled)

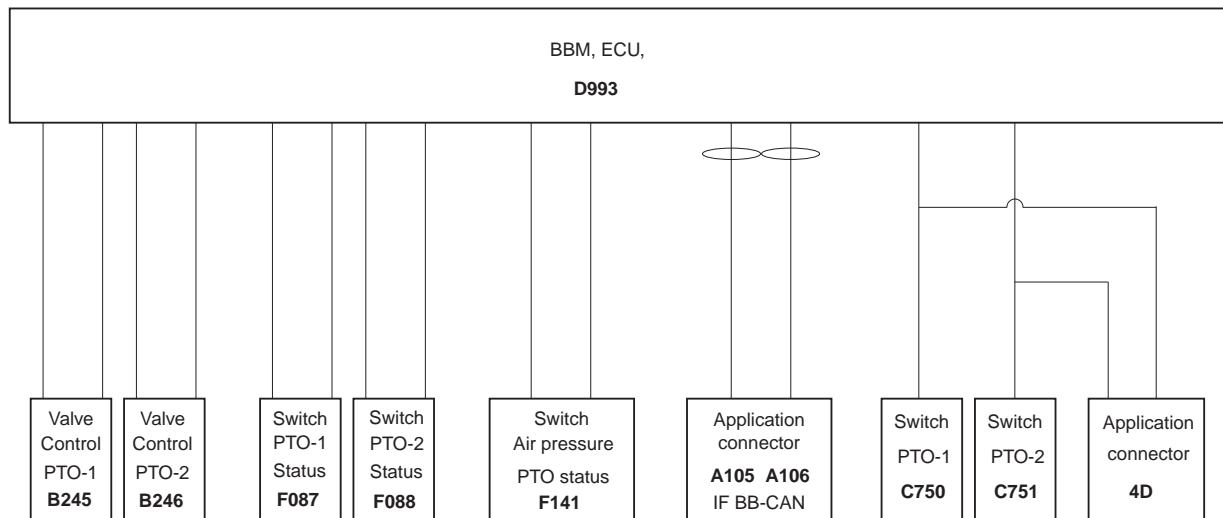

G001194

General PTO control system layout

BODYBUILDERS' GUIDELINES

Electrical system CF series

CAN signal description				
CAN Message name	Message id	Used CAN Signals for PTO ⁽¹⁾	Startbit	Length
TC01	0CFE6CEE	Tachograph vehicle speed	48	16
PropB_CXB	18FF80E6	PTO-1 CAN Switch	16	2
		PTO-2 CAN Switch	18	2
CCVS	18FEF100	Parking brake switch	2	2
		Brake switch	28	2
		Clutch switch	30	2
EEC1	0CF00400	Engine speed	24	16
PropB_BBM	18FF8225	PTO_1 indication	0	2
		PTO_2 indication	2	4
		PTO_1 Blinking	18	2
		PTO_2 Blinking	20	2
		PTO_1 not active warning	6	2
		PTO_2 not active warning	8	2
		PTO_1 warning	12	2
		PTO_2 warning	14	2

(1) only PTO control related messages are shown.

Engine PTO

For vehicles with a MX engine a special engine PTO can be used. This 12 o'clock engine PTO MX can, unlike the engine PTO for PR engines, be switched on and off when the engine is already running. The clutch of this PTO type is air pressure controlled. To make sure enough air pressure is available for engaging the clutch, an air pressure switch is added. This switch is added to an input of the BBM and is a switch on condition for this PTO type.

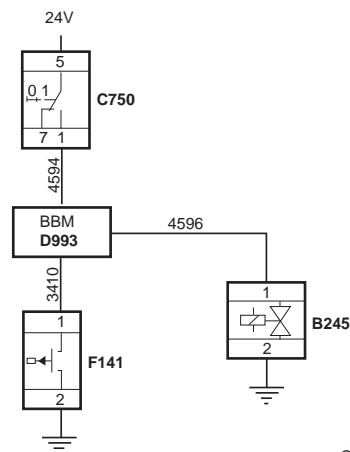

G001199

Gearbox PTO (manual gearbox)

Upto 2 PTO are incorporated in the electrical design of the CF series. Both PTO's can be operated and monitored from in-cab position, by wire from the outside via the bulkhead lead-through for PTO (connector 4D) (see 10.2: "CF series bulkhead connection overview") and via CAN control in case the PTO option and the BB-CAN option (see 8.6: "Body Builders' CAN J1939") is present.

PTO1 operation

By using the switch on position 8 (see section 10.1: "CF series cab switch and connector locations"), the BBM (Body Builder Module) is activated via wire 4594. The BBM checks on the basis of the cut-in conditions whether the output (wire 4596) may be activated. These conditions must be met within a specified control time (default = 4 s). The PTO output will not be switched on, even if following the expiry of the control time, the cut-in conditions are met. To allow the PTO to be switched on, the switch must first be set to off, and then switched back on.

If activation of the PTO is permitted, wire 4596 is activated, and the BBM expects a return status message from the PTO system, within a second control time. An immediate check will also be carried out as to whether the cut-out conditions are met, or not. If the return status message (wire 3410) does not arrive on time, or if the message states that the cut-out conditions are met, the output will be switched off, and the PTO warning will appear on the DIP (display on instrument panel). The 'PTO active' indication on the DIP will not illuminate, until the return status message is concluded successfully. If this indication lights up, the PTO-1 hour counter will start to run (installed in the DIP menu). Control wire 4594 (active +24V, in parallel connected to dashboard switch) is included in the ESC application connector, which means that preparation for operating the PTO (switching it on and keeping it running) from the body is provided. For manual gearboxes remote operation of the clutch must be realized (check ordering possibilities).

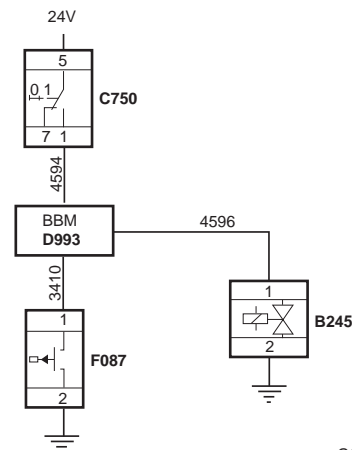

G001196-1

3 possible settings of the PTO interlocks are possible

- operation of PTO on a stationary vehicle (CP1-31)
- operation of PTO on a moving vehicle (CP1-31)
- individual settings of all conditions (see related customer parameters)

N10 Clutch protection (not clutch-misuse protection)

In order to switch on a torque-dependent PTO, the clutch pedal must be operated. The on/off condition laid down in the BBM responds if the pedal is depressed approx. 5 mm, which is not sufficient for the protection of the PTO and the gearbox (preventing misuse). If an N221/10 PTO is installed, the PTO operation must therefore be combined with extended clutch pedal protection; in that case, it is necessary to add the G259 relay. For additional information, contact DAF.

BODYBUILDERS' GUIDELINES

Electrical system CF series

PTO2 operation

Operation of the "PTO2" is identical to the PTO-1 operation, with exception of :

1. PTO-2 On/Off wire is 5241 (PTO-1 wire is 4594)
2. PTO-2 E/P activation wire is 4595 (PTO-1 wire is 4596) or 5149 with a N10 or Chelsea PTO
3. PTO-2 Status return wire is 3668 (PTO-1 wire is 3410)

PTO3 operation

On the dashboard, a switch position is provided for a 3rd PTO. The wiring for the 3rd PTO operation is prepared ex-factory and goes directly to the PTO3-valve without controlling by the BBM. An additional warning lamp can be fitted on the heater panel, beside the 2nd radio recess.

Gearbox PTO (Automatic gearbox)

In general the PTO operation (including the interlocks) in combination with automatic gearboxes is identical to the manual gearbox PTO operation, with the following exception;

After switching the PTO on and complying with the interlocks programmed, the E/P valve output (2) of the BBM is activated. This signal is used by the automatic gearbox control unit (AGC-A4) as a request for activating the gearbox PTO. The automatic gearbox control unit checks its internal parametring (see chapter 7.15: "Automated and automatic gearboxes") whether the PTO can be switched on.

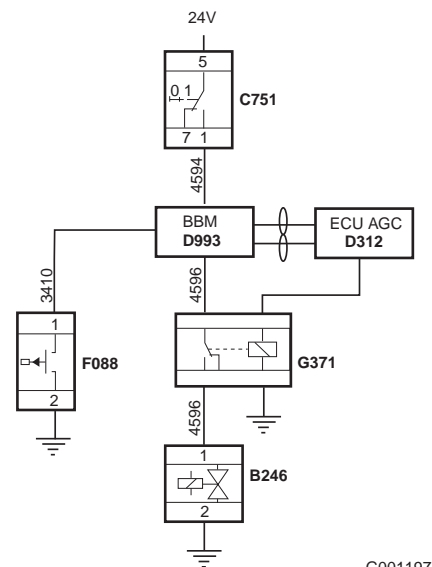

G001197

Gearbox PTO (Automated gearbox)

DAF introduced an automated gearbox called AS-Tronic. This is a mechanical gearbox, which is operated via an electronic control unit. This means that some of the driver's tasks are monitored or taken over.

The PTO which is fitted to this gearbox, therefore has a control/protection system that is different from that used in combination with the manually operated gearboxes.

There is a choice between two settings of the PTO interlocks:

- operation of PTO on a stationary vehicle
- operation of PTO on a moving vehicle

Operation of PTO on a stationary vehicle is always the basic setting

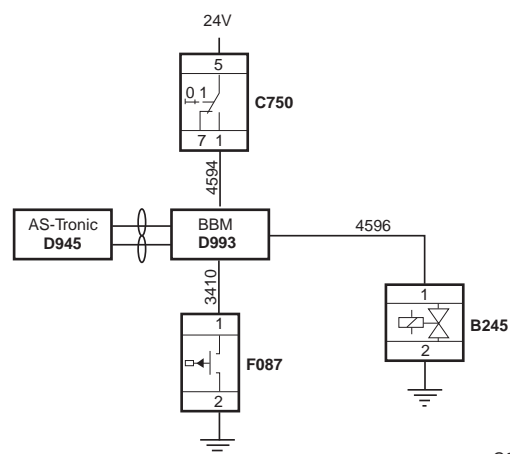

G001198-1

Cut-in conditions:

- The handbrake must be active
- The engine is running
- The gearbox must be in neutral
- The engine speed is lower than Nmax cut-in (650 rpm)
- The vehicle speed is lower than 1.5 km/h

Cut-out conditions:

- The handbrake must be de-activated
- The engine is not running
- The vehicle contact is switched off
- The vehicle speed is higher than 1.5 km/h

Gear-shift commands are not carried out during PTO operation.

Operation of PTO on a moving vehicle should be activated using the diagnostic tool (DAVIE XD)

Cut-in conditions:

- The handbrake must be active
- The engine is running
- The gearbox must be in neutral
- The engine speed is lower than Nmax cut-in (650 rpm)
- The vehicle speed is lower than 1.5 km/h

Cut-out conditions:

- The engine is not running
- The vehicle contact is switched off

Changing gear during driving is not possible. So when driving off, the gear eventually required during driving should already be engaged!

Note:

AS-Tronic software version may limit instationary PTO use, to 1st and RL gear with direct drive gearboxes and to 2nd and RH gear with overdrive gearboxes. No gearchange possible with these versions. Check the vehicle configuration on this in case instationary PTO use is required.

Depending on the situation, the PTO warning is given between 2 and 5 seconds after a defect or undesirable situation occurs.

Note:

When the PTO is engaged, programmed to instationary use, and crawler gears are selected:

- **As lowest gearing, gears 1 and RL are available for Direct Drive (DD) gearboxes**
- **As lowest gearing, gears 2 and RH are available for Over Drive (OD) gearboxes**

BODYBUILDERS' GUIDELINES

Electrical system CF series

Activation of PTO control via CAN message PropB_CXB

In addition to engage the PTO via the hardwired option, it is also possible, providing selection code 9562 "with application connector body builder CAN" has been chosen, to activate this via CAN. To be able to use this functionality, the body must provide CAN message PropB_CXB with identifier 18_FF_80_E6 to pin 17 and 18 of connector 12D. The data that must be provided in this message is as follows:

Signal name	Byte	Bit	Type	Offset	Min	Max	Unit	Comments
CXB Remote PTO 1	3	2,1	Status	-	0	3	-	00 _b =passive 10 _b =error 01 _b =active 11 _b =not available
CXB Remote PTO 2	3	4,3	Status	-	0	3	-	00 _b =passive 10 _b =error 01 _b =active 11 _b =not available

PTO hour counter(s)

As is clear from the above, vehicles can be equipped with one or more PTO's. The function of the PTO hour counter is to record the number of additional engine operating hours during PTO operation, and if possible, to take them into account when determining the vehicle's maintenance intervals. Readout of the number of PTO hours is via the DOT matrix display using the menu control switch on the dashboard (DIP) or via DAVIE. The operating time (in hours) of a maximum of 2 PTO's can be read out via the display. If PTO1 is switched on, the operating time is automatically added to the total for PTO1. When PTO2 is switched on, the operating time is automatically added to the total for PTO2. Both PTO1 and PTO2 can be reset using DAVIE. The PTO counters will become visible after more than 1 minute operation.

A separate hour counter is available as analogue gauge. See chapter 8.5: "CVSG type gauges".

Customer parameter list

In the next tables all related customer parameters are listed.

BODYBUILDERS' GUIDELINES

Electrical system CF series

Customer parameter ID ⁽¹⁾	Customer parameter name	System	Value
	PTO-1/2 switch on conditions		
1-01 / 1-45	PTO 1/2 ON - brake valid	BBM	ACTIVE / NOT ACTIVE
1-02 / 1-46	PTO 1/2 ON - brake use	BBM	PRESSED / RELEASED
1-03 / 1-47	PTO 1/2 ON - clutch valid	BBM	ACTIVE / NOT ACTIVE
1-04 / 1-48	PTO 1/2 ON - clutch use	BBM	PRESSED / RELEASED
1-05 / 1-49	PTO 1/2 ON - park brake valid	BBM	ACTIVE / NOT ACTIVE
1-06 / 1-50	PTO 1/2 ON - park brake use	BBM	APPLIED / RELEASED
1-07 / 1-51	PTO 1/2 ON - engine running valid	BBM	ACTIVE / NOT ACTIVE
1-08 / 1-52	PTO 1/2 ON - engine running use	BBM	RUNNING / NOT RUNNING
1-09 / 1-53	PTO 1/2 ON - maximum engine speed	BBM	Rpm
1-10 / 1-54	PTO 1/2 ON - maximum vehicle speed	BBM	km/h
1-88	PTO 1 ON - minimum engine speed	BBM	Rpm
1-89	PTO 1 ON - pressure switch	BBM	ACTIVE / NOT ACTIVE

(1) For changing default parameter settings see chapter 7.19: "Guideline for the Customer Parameter Change Form"

BODYBUILDERS' GUIDELINES

Electrical system CF series

Customer parameter ID ⁽¹⁾	Customer parameter name	System	Value
	PTO-1/2 switch off conditions		
1-12 / 1-55	PTO 1/2 OFF - brake valid	BBM	ACTIVE / NOT ACTIVE
1-13 / 1-56	PTO 1/2 OFF - brake use	BBM	PRESSED / RELEASED
1-14 / 1-57	PTO 1/2 OFF - clutch valid	BBM	ACTIVE / NOT ACTIVE
1-15 / 1-58	PTO 1/2 OFF - clutch use	BBM	PRESSED / RELEASED
1-16 / 1-59	PTO 1/2 OFF - park brake valid	BBM	ACTIVE / NOT ACTIVE
1-17 / 1-60	PTO 1/2 OFF - park brake use	BBM	APPLIED / RELEASED
1-18 / 1-61	PTO 1/2 OFF - engine running valid	BBM	ACTIVE / NOT ACTIVE
1-19 / 1-62	PTO 1/2 OFF - engine running use	BBM	RUNNING / NOT RUNNING
1-20 / 1-63	PTO 1/2 OFF - maximum engine speed	BBM	Rpm
1-21 / 1-64	PTO 1/2 OFF - maximum vehicle speed	BBM	km/h

(1) For changing default parameter settings see chapter 7.19: "Guideline for the Customer Parameter Change Form"

Customer parameter ID ⁽¹⁾	Customer parameter name	System	Value
	PTO-1/2 other		
1-31 / 1-65	PTO 1/2 Type	BBM	STATIONARY / IN-STATIONARY / ENGINE
1-34 / 1-66	PTO 1/2 On Timeout	BBM	Milliseconds
1-35 / 1-67	PTO 1/2 Off Timeout	BBM	Milliseconds
1-91	PTO 1 OFF Time	BBM	Milliseconds

(1) For changing default parameter settings see chapter 7.19: "Guideline for the Customer Parameter Change Form"

BODYBUILDERS' GUIDELINES

Electrical system CF series

Customer parameter ID ⁽¹⁾	Customer parameter name	System	Value
	AStronic PTO-1/2 switch on conditions		
1-68 / 1-76	PTO 1/2 ON - park brake valid	BBM	ACTIVE / NOT ACTIVE
1-69 / 1-77	PTO 1/2 ON - park brake use	BBM	APPLIED / RE-LEASED
1-70 / 1-78	PTO 1/2 ON - maximum engine speed	BBM	Rpm
1-71 / 1-79	PTO 1/2 ON - maximum vehicle speed	BBM	km/h

(1) For changing default parameter settings see chapter 7.19: "Guideline for the Customer Parameter Change Form"

Customer parameter ID ⁽¹⁾	Customer parameter name	System	Value
	AStronic PTO-1/2 switch off conditions		
1-73 / 1-81	PTO 1/2 OFF - park brake valid	BBM	ACTIVE / NOT ACTIVE
1-74 / 1-82	PTO 1/2 OFF - park brake use	BBM	APPLIED / RE-LEASED
1-32 / 1-83	PTO 1/2 OFF - maximum engine speed	BBM	Rpm
1-75 / 1-84	PTO 1/2 OFF - maximum vehicle speed	BBM	km/h

(1) For changing default parameter settings see chapter 7.19: "Guideline for the Customer Parameter Change Form"

Customer parameter ID ⁽¹⁾	Customer parameter name	System	Value
	AStronic PTO-1/2 other		
1-31 / 1-65	PTO 1/2 Type	BBM	STATIONARY / IN-STATIONARY / ENGINE
1-33 / 1-85	AStronic PTO 1/2/ Time		Milliseconds
1-34 / 1-66	PTO 1/2 On Timeout	BBM	Milliseconds
1-35 / 1-67	PTO 1/2 Off Timeout	BBM	Milliseconds

(1) For changing default parameter settings see chapter 7.19: "Guideline for the Customer Parameter Change Form"

BODYBUILDERS' GUIDELINES

Electrical system CF series

Customer parameter ID ⁽¹⁾	Customer parameter name	System	Value
	Remote engine start/stop PTO-1/2 control		
1-118	Remote engine start/stop PTO 1 control	BBM	ENABLED / DISABLED
1-119	Remote engine start/stop PTO 2 control	BBM	ENABLED / DISABLED

(1) For changing default parameter settings see chapter 7.19: "Guideline for the Customer Parameter Change Form"

10.19 REFUSE PREPARATION CF75 - CF85 SERIES

The CF series can be specified with Selco 9240, which will offer a 12 pole application connector for lighting (see section: 12.39: "Connector A113 garbage truck") and a 21 pole application connector for Refuse collector bodies (see section: 12.30: "Connector A095 application refuse collector"). The counter connector for A095 is called A134 (see section: 12.45: "Connector A134 refuse feed through wire") and is prepared with a single (loop) wire to ground. Signal processing is carried out in a BBM (Body Builder Module) application. Additional a modified rear overhang can be specified by selecting an AE of 740, 920 or 1000 mm. The electrical connections are positioned in the bulkhead lead through and can be made by means of the standard DAF connectors.

A refuse preparation enables a body builder to activate special refuse functionality such as:

1. Stop&Go
 2. Body Release
 3. Body Active
 4. High rpm Request
 5. Vehicle speed limitation with operated footboard
 6. Remote engine start
 7. Remote engine stop
 8. Brake control
 9. Speed Switches
1. Stop&Go
This function automates the process of shifting from drive to neutral at vehicle standstill and shifting from neutral to drive when driving off without the driver manually have to operate the gear shift selector. The Stop&Go function can be activated and deactivated by the driver by operating the toggle switch. When this function is active, the superstructure of a refuse truck can set a

high idle speed or customer to derive mechanical energy from the vehicle to activate special functions, e.g. pumps. A PTO can be switched on by activating an EP valve. The driver can request activation of the PTO by activating a PTO switch. Before activating the PTO the BBM will check if the switch-on conditions are met. Also the PTO will be disabled if, with an activated PTO, one of the switch-off conditions are met. The switch on and off conditions can be adjusted by the DAF dealer via DAVIE. Up to two PTO's can be controlled by the Body Builder Module.

2. **Body Release.**
This function can be used to provide the body builder with the information that the vehicle is in a secure state of operation. The body builder can use this signal to safely operate/control the superstructure. It is possible to configure the reset conditions for body release by adjusting the customer parameters.
3. **Body Active.**
This function is a safety function and will enable or disable the outputs to the function body release and high rpm request depending on the input status body active. If the body active input is enabled both separate outputs will be set for activation. The outputs will be enabled if the related input for this output (high rpm request and body release) are active. These outputs will be disabled if the enable condition aren't met anymore.
4. **High rpm request.**
This function is to set a predefined engine speed when a high engine speed is requested by the superstructure. The requested engine speed will only be set if the switch on conditions are met. This enables the superstructure of a refuse truck to set a high idle engine speed N3 in neutral gear position at vehicle standstill. The superstructure can request this high idle engine speed to drive a hydro pump to perform a press cycle. When the autoneutral request is released, engine speed N2 (reduced high idle speed) is set and the engine speed drops in order to enable the Allison gearbox to shift from neutral to drive (Stop&Go functionality) and to limit clutch wear with manual gearboxes.
5. **Vehicle speed limitation with active footboard.**

BODYBUILDERS' GUIDELINES

Electrical system CF series

In this function the Vmax application input or application speed limiter input from a body builder CAN message is used to set the signal application speed limiter in a CAN message to the engine ECU. The function can be used by the body builder e.g. limiting speed if a person is on the footboard of a garbage truck. The speed limit value can be adjusted by a customer parameter.

6. Body Release.

This function can be used to provide the body builder with the information that the vehicle is in a secure state of operation. The body builder can use this signal to safely operate/control the superstructure. It is possible to configure the reset conditions for body release by adjusting the customer parameters.

7. Remote engine start.

In the function Remote Engine Start the Remote Engine Start input from the engine application connector or the engine start signal from a CAN message or the internal engine start (start/stop) signal is used to control the Remote Engine Start output. This output is directly connected to the starter engine relay. The body builder can use this function to start the engine from outside the cabin. This function can be used to provide the body builder with the information that the vehicle is in a secure state of operation. The body builder can use this signal to safely operate/control the superstructure. It is possible to configure the reset conditions for body release by adjusting the customer parameters.

8. Remote engine stop.

In the function Remote Engine Stop the Remote Engine Stop input from the engine application connector or internal Start/Stop or Engine Stop from a Body builder CAN message is used to set the signal Engine Stop in a CAN message to the Engine ECU. This function can be used by the body builder to connect an stop button.

9. Brake Control.

If somebody is standing on the footboard of a refuse truck, reversing of the vehicle shall be made impossible. For refuse trucks the parking brake must and engine stop can be activated when reverse gear is selected while the refuse step switch (Vmax application) is active. The parking brake must be kept active until KL15 is switched off. For safety reasons, this functions can only be activated if the vehicle speed is below a predefined speed (default 30km/h) To activate the

parking brake the BBM activates a 3/2 electro pneumatic valve (via a relay) which depressurizes the spring brakes. To activate the engine stop, the BBM sends a CAN message to the engine.

10. Speed switches.

This function is to provide three information signals to the body builder; two for indicating that the vehicle speed is above a predefined speed (5km/h or 10km/h) and one for indicating that the engine speed is above a predefined value (1400rpm)

Customer parameter list in BBM unit

Customer Parameter ID ⁽¹⁾	Customer Parameter Name	Value (Recommended)
	PTO status out	
1-94	PTO input	NO PTO PTO 1 status PTO 2 status PTO 1 and 2 status

(1) For changing default parameter settings see chapter 7.19: "Guideline for the Customer Parameter Change Form".

	Body Release Refuse	
1-99	Body release	DEACTIVATED
1-101	Driveline engaged	NOT ACTIVE
1-102	Maximum engine speed	Rpm
1-103	Park Brake	APPLIED / RELEASED
1-104	Maximum vehicle speed	Km/h

	Engine running	
1-105	Engine running	ENABLED

	Remote engine start/stop parameters	
1-86	Engine start enable	ENABLED
1-87	Engine stop maximum speed	0 km/h

	Speed switches	
1-95	RPM switch	1400 Rpm
1-96	Vehicle speed switch 1	5 km/h
1-97	Vehicle speed switch 2	10 Km/h

	Stop & Go Allison	
1-127	External auto neutral request	DISABLED

BODYBUILDERS' GUIDELINES

Electrical system CF series

	CVSG (Gauges)	
1-120	Coolant temperature	DISABLED
1-121	Oil pressure	DISABLED
1-122	Oil temperature	DISABLED
1-123	Fuel level	DISABLED
1-124	Transmission oil temperature	DISABLED
1-125	Air pressure circuit 1	DISABLED
1-126	Air pressure circuit 2	DISABLED

	Fault detection Vmax Application pin C17	
1-128	Fault detection pin C17	Open circuit / Short circuit ground

Customer parameter list in DMCI unit

Customer Parameter ID ⁽¹⁾	Customer Parameter Name	Value (Recommended)
	LIMITERS	
2-10	Vmax APPLICATION SPEED	30 Km/h
2-11	vmax ESC	30 Km/h
2-37	TORQUE REDUCTION ESC	0 %
2-12	MAX. CRUISE CONTROL SPEED	85 Km/h

(1) For changing default parameter settings see chapter 7.19: "Guideline for the Customer Parameter Change Form".

	ENGINE SPEED CONTROL	
2-14	MAX. ESC-SPEED	1500 Rpm
2-15	MIN. ESC-SPEED	600 Rpm
2-18	ACCELERATION RAMP CONTINUOUS UP ESC	200 Rpm/s
2-19	ACCELERATION RAMP CONTINUOUS DOWN ESC	200 Rpm/s
2-20	ACCELERATE UP PER TIP	25 Rpm/tip
2-38	DEACCELERATE DOWN PER TIP	25 Rpm/tip
2-22	ACCELERATE FROM IDLE TO TARGET SPEED IN ESC	1000 Rpm/s
2-39	DEACCELERATE FROM TARGET SPEED IN ESC TO IDLE	1000 Rpm/s
2-16	ESC CAB N1	600 Rpm
2-17	ESC CAB N2	600 Rpm
2-28	ESC CHANGE APPLICATION CONN. N2	850 Rpm
2-29	ESC CHANGE APPLICATION CONN. N3	1100 Rpm

	ENGINE SPEED CONTROL CONDITIONS	
2-30	ACCEL. PEDAL	ACTIVE
2-31	MAX. RPM ACCEL. PEDAL	1500 Rpm

	ENGINE SPEED CONTROL CONDITIONS	
2-32	PARK BRAKE	NOT ACTIVE
2-33	BRAKE	NOT ACTIVE



NOTE: Activating the auxiliary STOP input on pin 20, forces the body release output to be switch off. In case this function is used, the high RPM request coming form the body also has to be disabled.



NOTE: On the majority of input and outputs diagnosis on short circuit to ground or +24V is carried out. In case pins of the 21pole connector are not used, it may result in an BBM warning on the dashboard display. Using pull-down resistors (1k Ω , ¼ Watt) to vehicle ground (in case of BBM reports error - short circuit to +24V) or pull-up resistors (1k Ω , ¼ Watt) to KL15 switched power supply (in case of BBM reports error - short circuit to ground) will solve the problem.



NOTE: For minimum currents applicable see chapter 7.8: "EMC compatibility"



NOTE: Depending on the application of the vehicle (rearloader, side loader etc.) one or more functions could have to be modified. Please prepare a clear list of desired functionality and contact the local sale engineering department so we can advise you on how the make the vehicle+superstructure working as desired.

10.20 HYDRAULIC PLATFORM CF75 SERIES

The CF series can be specified with Selco 2950, which will offer a 9 pole application connector (see section: 12.41: "Connector A122 hydraulic platform 9-pole" and a 21 pole application connector (see section: 12.42: "Connector A123 hydraulic platform 21-pole" for Hydraulic platform bodies. The counter connector for A123 is called A125 (see section: 12.43: "Connector A125 hydraulic platform feed through" and is prepared with a number of power supply wires . Signal processing is carried out in a BBM (Body Builder Module) application. Additional an automatic

BODYBUILDERS' GUIDELINES

Electrical system CF series

gearbox and air suspension on the rear axle is required. The electrical connections are positioned in the bulkhead lead through and can be made by means of the standard DAF connectors.

Customer parameter list in BBM unit

Customer ⁽¹⁾ Parameter ID	Customer Parameter Name	Value (Recommended)
	PTO status out	
1-94	PTO input	NO PTO PTO 1 status PTO 2 status PTO 1 and 2 status

(1) For changing default parameter settings see chapter 7.19: "Guideline for the Customer Parameter Change Form"

	Engine running	
1-105	Engine running	ENABLED

	Remote engine start/stop parameters	
1-86	Engine start enable	ENABLED
1-87	Engine stop maximum speed	0 km/h

	Speed switches	
1-95	RPM switch	1400 Rpm
1-96	Vehicle speed switch 1	5 km/h
1-97	Vehicle speed switch 2	10 Km/h

	CVSG (Gauges)	
1-120	Coolant temperature	DISABLED
1-121	Oil pressure	DISABLED
1-122	Oil temperature	DISABLED
1-123	Fuel level	DISABLED
1-124	Transmission oil temperature	DISABLED
1-125	Air pressure circuit 1	DISABLED
1-126	Air pressure circuit 2	DISABLED

Customer parameter list in DMCI unit

Customer Parameter ID	Customer Parameter Name	Value (Recommended)
	LIMITERS	
2-10	Vmax APPLICATION SPEED	30 Km/h
2-11	vmax ESC	30 Km/h
2-37	TORQUE REDUCTION ESC	0 %
2-12	MAX. CRUISE CONTROL SPEED	85 Km/h

(1) For changing default parameter settings see chapter 7.19: "Guideline for the Customer Parameter Change Form"

	ENGINE SPEED CONTROL	
2-14	MAX. ESC-SPEED	1500 Rpm
2-15	MIN. ESC-SPEED	600 Rpm
2-18	ACCELERATION RAMP CONTINUOUS UP ESC	200 Rpm/s
2-19	ACCELERATION RAMP CONTINUOUS DOWN ESC	200 Rpm/s
2-20	ACCELERATE UP PER TIP	25 Rpm/tip
2-38	DEACCELERATE DOWN PER TIP	25 Rpm/tip
2-22	ACCELERATE FROM IDLE TO TARGET SPEED IN ESC	1000 Rpm/s
2-39	DEACCELERATE FROM TARGET SPEED IN ESC TO IDLE	1000 Rpm/s
2-16	ESC CAB N1	600 Rpm
2-17	ESC CAB N2	600 Rpm
2-28	ESC CHANGE APPLICATION CONN. N2	850 Rpm
2-29	ESC CHANGE APPLICATION CONN. N3	1100 Rpm

	ENGINE SPEED CONTROL CONDITIONS	
2-30	ACCEL. PEDAL	ACTIVE
2-31	MAX. RPM ACCEL. PEDAL	1500 Rpm
2-32	PARK BRAKE	NOT ACTIVE
2-33	BRAKE	NOT ACTIVE



NOTE: Activating the auxiliary STOP input on pin 20, forces the body release output to be switch off. In case this function is used, the high RPM request coming from the body also has to be disabled.

BODYBUILDERS' GUIDELINES

Electrical system CF series



NOTE: On the majority of input and outputs diagnosis on short circuit to ground or +24V is carried out. In case pins of the 21pole connector are not used, it may result in an BBM warning on the dashboard display. Using pull-down resistors (1k Ω , ¼ Watt) to vehicle ground (in case of BBM reports error - short circuit to +24V) or pull-up resistors (1k Ω , ¼ Watt) to KL15 switched power supply (in case of BBM reports error - short circuit to ground) will solve the problem.

ELECTRICAL SYSTEM XF SERIES

	Page	Date
11.1 XF series cab switch and connector locations.....	337	201019
11.2 XF series bulkhead connection overview	339	201019
11.3 XF series accessories in headershell	339	201019
11.4 XF series accessories connection in dashboard.....	339	201019
11.5 XF series power supply	340	201019
11.6 XF series radio preparation	340	201019
11.7 XF series CB preparation	340	201019
11.8 XF series telephone preparation	340	201019
11.9 XF series anti-theft protection	340	201019
11.10 XF series refrigerator preparation	340	201019
11.11 XF series LED preparation immobiliser / Alarm.....	341	201019
11.12 XF series microwave preparation	341	201019
11.13 XF series chassis connections	341	201019
11.14 XF series ESC control	341	201019
11.15 XF series FMS system	341	201019
11.16 XF series PTO controls / protection.....	342	201019
11.17 XF series trailer connection points	351	201019

BODYBUILDERS' GUIDELINES

Electrical system XF series

11.ELECTRICAL SYSTEM XF SERIES

11.1 XF SERIES CAB SWITCH AND CONNECTOR LOCATIONS

Switch positions, overhead consoles

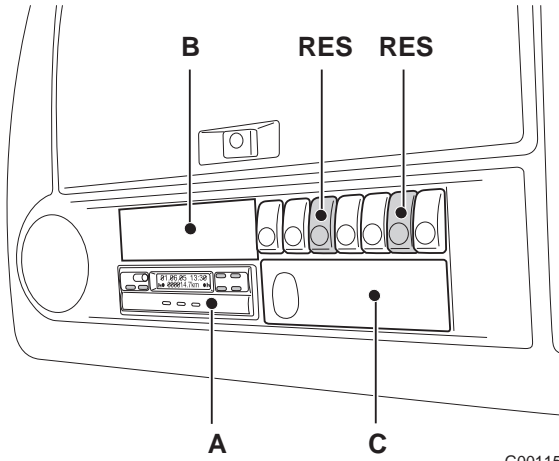

G001154

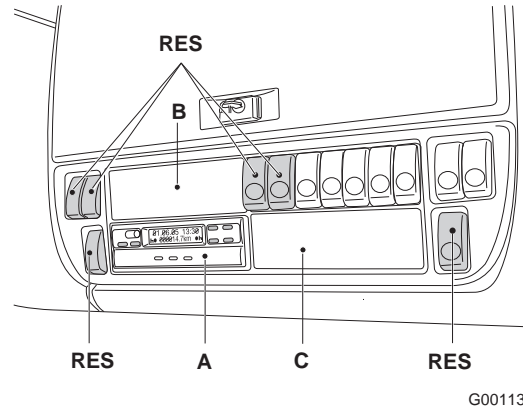

G001136

Space Cab

Super Space Cab

- A Tachograph
- B Toll Collect (ECU) connector (See 12.48: "Connector D318 (ECU) Toll Collect".)
- C Spare / CB / telephone microfoon
- RES Spare location

BODYBUILDERS' GUIDELINES

Electrical system XF series

Switch position, dashboard

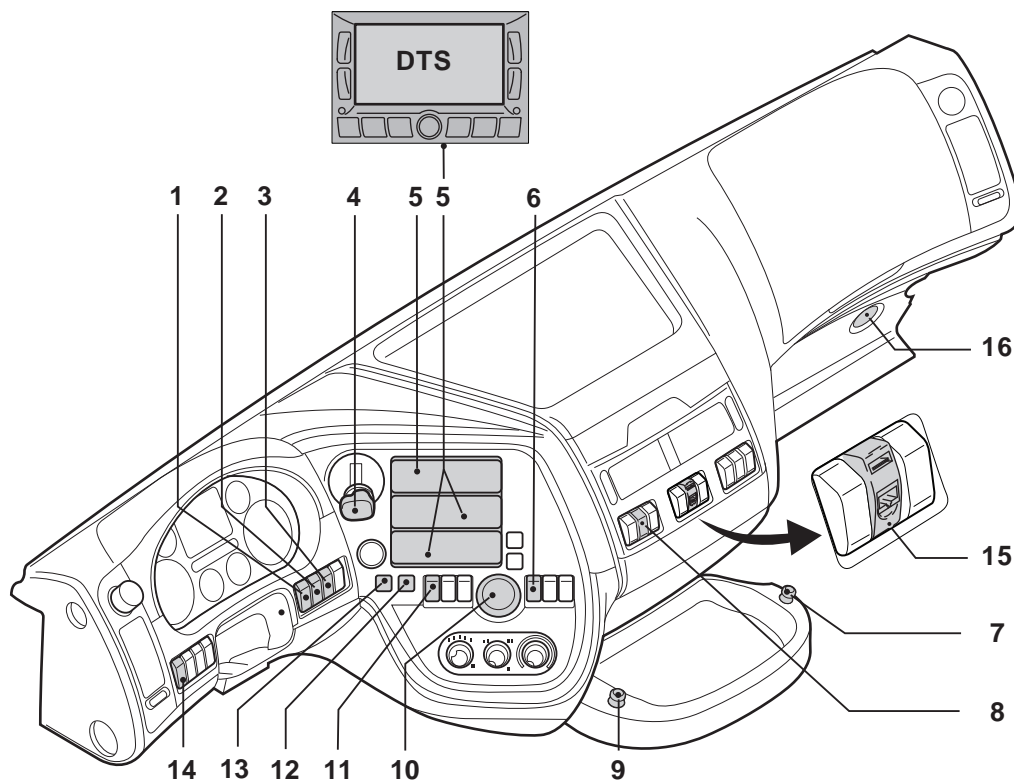

G001171

- 1 PTO-1
- 2 PTO-2
- 3 loading door alarm on/off
- 4 parking brake lever
- 5 radio recess 1,2,3 DIN slots
- 6 brake integration / Traction aid FTM / Liftaxle up FAK
- 7 24V accessory plug
(See 12.21: "Connector A007 accessories 24V 2-pole".)
- 8 main switch
- 9 12V accessory plug with cigar lighter
(See 12.22: "Connector A011 accessories 12V 2-pole".)
- 10 AS-Tronic D-N-R (Drive-Neutral-Reverse) switch
- 11 spare location
- 12 spare location
- 13 switch reverse alarm outside on/off
- 14 switch worklamp cab back / taillift enable
- 15 LAN and USB connector telematics
- 16 HD OBD plug
(See 12.33: "Connector A100 HD-OBD diagnose".)

For an overview of available switches and symbols, see section 13.9: "Switches".

11.2 XF SERIES BULKHEAD CONNECTION OVERVIEW

The connections in the CF and XF bulkhead panels are the same, see section 10.2: "CF series bulkhead connection overview" for more information.

11.3 XF SERIES ACCESSORIES IN HEADERSHELF

Wiring headershelf

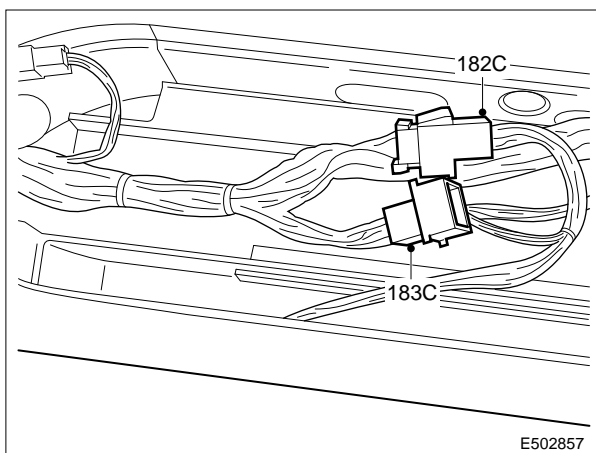

Super Space Cab

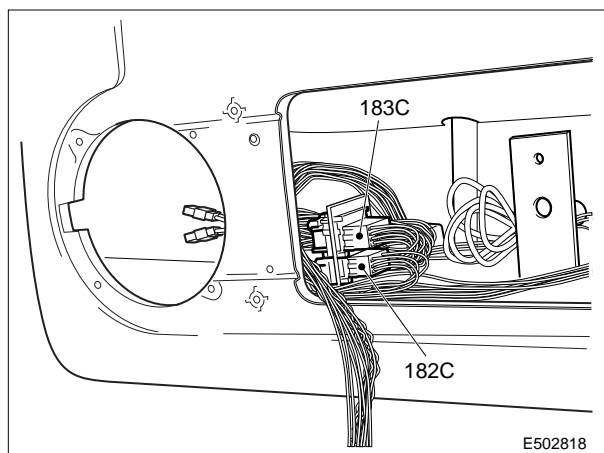

Space Cab

There are several connectors available in the headershelf at the driver side. Check the sections indicated below for additional information on pinning and wire numbers within the connectors used:

- 9-pin connector 182C: in section 12.15: "Connector 182C power supply".
- 12-pin connector 183C: in section 12.11: "Connector 12D body builder".

Spare wiring

There is no spare wiring from dashboard area via the A-pillar to the headershelf.

11.4 XF SERIES ACCESSORIES CONNECTION IN DASHBOARD

The accessories connection in the CF and XF dashboard are the same, see section 10.5: "CF series accessories connection in dashboard" for more information.

BODYBUILDERS' GUIDELINES

Electrical system XF series

11.5 XF SERIES POWER SUPPLY

The power supply connection of the CF and XF dashboard are the same, see section 10.6: "CF series power supply" for more information.

11.6 XF SERIES RADIO PREPARATION

The radio preparation of the CF and XF series are the same, see section 10.7: "CF series radio preparation" for more information.

11.7 XF SERIES CB PREPARATION

The CB preparation of the CF and XF series are the same, see section 10.8: "CF series CB preparation" for more information.

11.8 XF SERIES TELEPHONE PREPARATION

The telephone preparation of the CF and XF series are the same, see section 10.9: "CF series telephone preparation" for more information.

11.9 XF SERIES ANTI-THEFT PROTECTION

XF series

The alarm system of the XF series is the same as that of the CF series. The only difference is the position of the interior IR and UR sensors.



WARNING! For the latest details and versions, contact DAF.

11.10 XF SERIES REFRIGERATOR PREPARATION

The refrigerator preparation of the CF and XF series are the same, see section 10.11: "CF series refrigerator preparation" for more information.

11.11 XF SERIES LED PREPARATION IMMOBILISER / ALARM

The LED preparation immobiliser / Alarm of the CF and XF series are the same, see section 10.12: "CF series LED preparation immobiliser / Alarm" for more information.

11.12 XF SERIES MICROWAVE PREPARATION

Microwave preparation

This is a 2-pole connector (connector code A038). This 2-pole connector is designed for currents up to 40 A!. The wires 1175 (KI30) and M22 (earth) are both 4,0 mm². The power supply is taken via fuse E168 KI30 (before contact). The fuse is a MAXI FUSE, located on the top side of the fuse-relay board.

In addition a connecting block can be connected here, and so creating a central point for power supply KI30 and earth. See also chapter 7.4: "Earth connections".

See section 12.23: "Connector A038 accessories" for more additional information on pinning and wire numbers within this connector used.

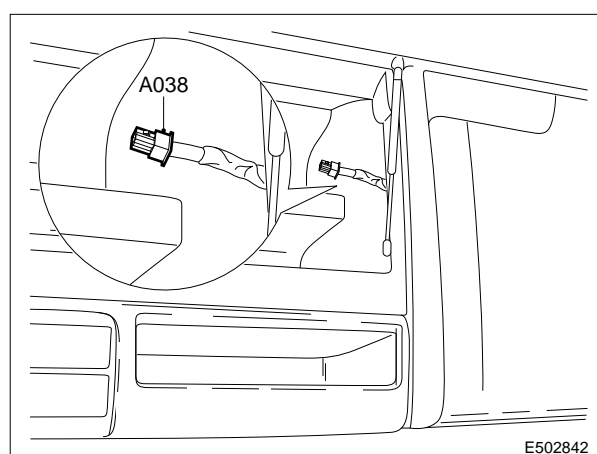

11.13 XF SERIES CHASSIS CONNECTIONS

The XF and CF series chassis connections are the same. Please use section 10.3: "CF75 and CF85 series chassis connections" for all information.

11.14 XF SERIES ESC CONTROL

DMCI engine control functionality

The DMCI engine speed control functionality of the XF and CF85 series with MX engine is the same. Please use chapter 10.16: "CF75 - CF85 ESC system" for all information.

11.15 XF SERIES FMS SYSTEM

XF series FMS system

The FMS system functionality of the XF and CF series is the same. Please use chapter 10.17: "CF75 - 85 series FMS / DTS system" for all information.

BODYBUILDERS' GUIDELINES

Electrical system XF series

11.16 XF SERIES PTO CONTROLS / PROTECTION

XF105 Series PTO-control

Applicable selection codes:

Selco codes	description
4610	without engine PTO
9181	with engine PTO / without control
9581	with engine PTO / with control

Selco codes	description
1412	without gearbox PTO-1 / without control
1118	with gearbox PTO-1 / without control
various	with gearbox PTO / with control

Selco codes	description
4852	without gearbox PTO-2 / without control
various	with gearbox PTO-2 / with control

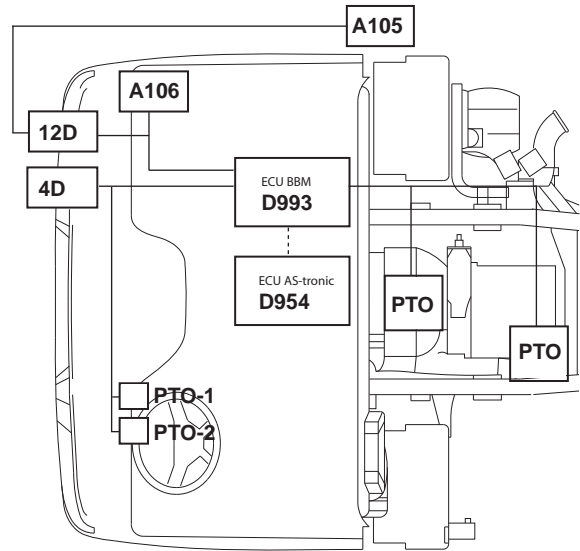

G001207

Applicable application connectors in cab and chassis depending on selection code:

Connector Codes	See the sections indicated below for additional information on pinning and wire numbers in the connectors used.
A105	section: 12.37: "Connector A105 Bodybuilder CAN system 7-pole"
A106	section: 12.38: "Connector A106 CAN-cab 9-pole"
4D	section:12.7: "Connector 4D PTO control system"
12D	section:12.11: "Connector 12D body builder"

Purpose of the function

A PTO (power take off) enables a body builder or customer to derive mechanical energy from the vehicle to activate special functions, e.g. pumps. A PTO can be switched on by activating an EP valve. The driver can request activation of the PTO by activating a PTO switch. Before activating the PTO the BBM will check if the switch-on conditions are met. Also the PTO will be disabled if, with an activated PTO, one of the switch-off conditions are met. The switch on and off conditions can be adjusted by the DAF dealer via DAVIE. Up to two PTO's can be controlled by the Body Builder Module.

The main purpose of the PTO control system is to engage the PTO under safe conditions. The PTO can be used while driving or when idling by setting the correct customer parameters using DAVIE.

PTO configuration for vehicles with a manual gearbox.

PTO-1	PTO-2
Engine PTO	
Engine PTO	Gearbox PTO N1/ N4 ⁽¹⁾
Engine PTO	Gearbox PTO N10 ⁽¹⁾
-	Gearbox PTO N10 ⁽¹⁾
Gearbox PTO N1/N4 ⁽¹⁾	Gearbox PTO N10 ⁽¹⁾
Gearbox PTO N1/N4 ⁽¹⁾	

(1) In the BBM software no difference is made between N1, N4 or N10 PTO.

Schematic overview of PTO control

The diagram below provides a schematic overview of the PTO control. The two main groups for controlling the PTO can be identified as follows:

1. Enabling PTO control by the driver via the dashboard switches.
2. Enabling PTO control by the body via hardware connections (connector 4D) or via CAN.
 - Cab application connector (hard wired)
 - Chassis application connector (CAN controlled)

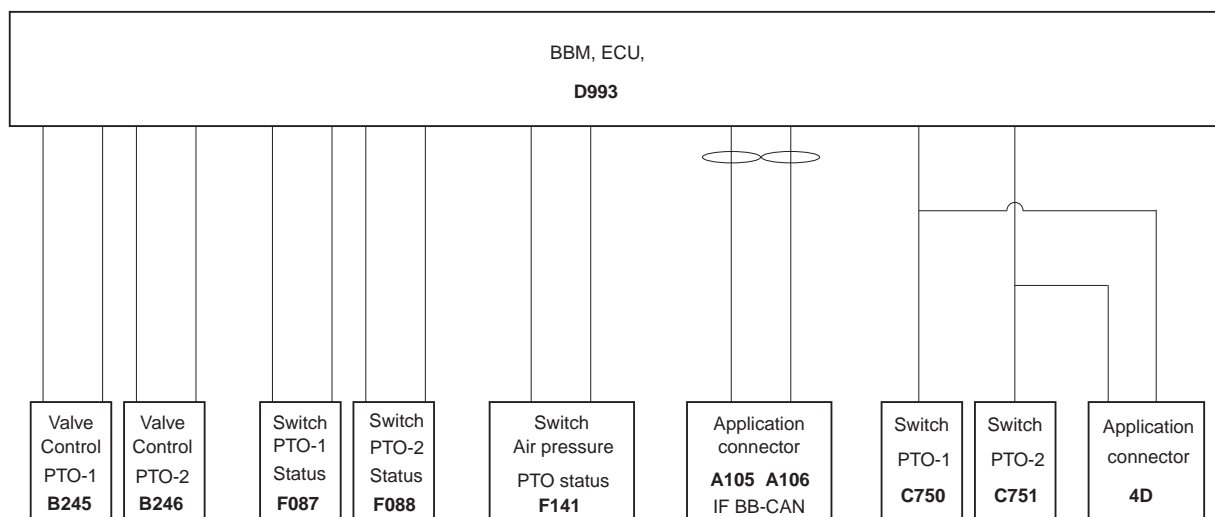

G001194

General PTO control system layout

BODYBUILDERS' GUIDELINES

Electrical system XF series

CAN signal description ⁽¹⁾				
CAN Message name	Message id	Used CAN Signals for PTO	Startbit	Length
TC01	0CFE6CEE	Tachograph vehicle speed	48	16
PropB_CXB	18FF80E6	PTO-1 CAN Switch	16	2
		PTO-2 CAN Switch	18	2
CCVS	18FEF100	Parking brake switch	2	2
		Brake switch	28	2
		Clutch switch	30	2
EEC1	0CF00400	Engine speed	24	16
PropB_BBM	18FF8225	PTO_1 indication	0	2
		PTO_2 indication	2	4
		PTO_1 Blinking	18	2
		PTO_2 Blinking	20	2
		PTO_1 not active warning	6	2
		PTO_2 not active warning	8	2
		PTO_1 warning	12	2
		PTO_2 warning	14	2

(1) only PTO control related messages are shown.

Engine PTO

For vehicles with a MX engine a special engine PTO can be used. This 12 o'clock engine PTO MX can be switched on and off when the engine is already running. The clutch of this PTO type is air pressure controlled. To make sure enough air pressure is available for engaging the clutch, an air pressure switch is added to an input of the BBM and is a switch on condition for this PTO type.

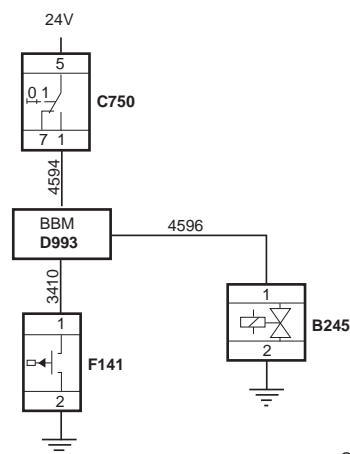

G001199

Gearbox PTO (manual gearbox)

Upto 2 PTO are incorporated in the electrical design of the XF series. Both PTO's can be operated and monitored from in-cab position, by wire from the outside via the bulkhead lead-through for PTO (connector 4D) (see 11.2: "XF series bulkhead connection overview") and via CAN control in case the PTO option and the BB-CAN option (see 8.6: "Body Builders' CAN J1939") is present.

PTO1 operation

By using the switch on position 8 (see section 11.1: "XF series cab switch and connector locations"), the BBM (Body Builder Module) is activated via wire 4594. The BBM checks on the basis of the cut-in conditions whether the output (wire 4596) may be activated. These conditions must be met within a specified control time (default = 4 s). The PTO output will not be switched on, even if following the expiry of the control time, the cut-in conditions are met. To allow the PTO to be switched on, the switch must first be set to off, and then switched back on.

If activation of the PTO is permitted, wire 4596 is activated, and the BBM expects a return status message from the PTO system, within a second control time. An immediate check will also be carried out as to whether the cut-out conditions are met, or not. If the return status message (wire 3410) does not arrive on time, or if the message states that the cut-out conditions are met, the output will be switched off, and the PTO warning will appear on the DIP (display on instrument panel). The 'PTO active' indication on the DIP will not illuminate, until the return status message is concluded successfully. If this indication lights up, the PTO-1 hour counter will start to run (installed in the DIP menu). Control wire 4594 (active +24V, in parallel connected to dashboard switch) is included in the ESC application connector, which means that preparation for operating the PTO (switching it on and keeping it running) from the body is provided. For manual gearboxes remote operation of the clutch must be realized (check ordering possibilities).

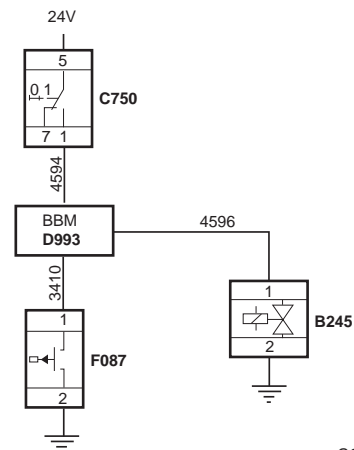

G001196-1

3 possible settings of the PTO interlocks are possible

- operation of PTO on a stationary vehicle (CP1-31)
- operation of PTO on a moving vehicle (CP1-31)
- individual settings of all conditions (see related customer parameters)

N10 Clutch protection (not clutch-misuse protection)

In order to switch on a torque-dependent PTO, the clutch pedal must be operated. The on/off condition laid down in the BBM responds if the pedal is depressed approx. 5 mm, which is not sufficient for the protection of the PTO and the gearbox (preventing misuse). If an N221/10 PTO is installed, the PTO operation must therefore be combined with extended clutch pedal protection; in that case, it is necessary to add the G259 relay. For additional information, contact DAF.

BODYBUILDERS' GUIDELINES

Electrical system XF series

PTO2 operation

Operation of the "PTO2" is identical to the PTO-1 operation, with exception of :

1. PTO-2 On/Off wire is 5241 (PTO-1 wire is 4594)
2. PTO-2 E/P activation wire is 4595 (PTO-1 wire is 4596) or 5149 with a N10 or Chelsea PTO
3. PTO-2 Status return wire is 3668 (PTO-1 wire is 3410)

PTO3 operation

On the dashboard, a switch position is provided for a 3rd PTO. The wiring for the 3rd PTO operation is prepared ex-factory and goes directly to the PTO3-valve without controlling by the BBM. An additional warning lamp can be fitted on the heater panel, beside the 2nd radio recess.

Gearbox PTO (Automated gearbox)

DAF introduced an automated gearbox called AS-Tronic. This is a mechanical gearbox, which is operated via an electronic control unit. This means that some of the driver's tasks are monitored or taken over. The PTO which is fitted to this gearbox, therefore has a control/protection system that is different from that used in combination with the manually operated gearboxes.

There is a choice between two settings of the PTO interlocks:

- operation of PTO on a stationary vehicle
- operation of PTO on a moving vehicle

Operation of PTO on a stationary vehicle is always the basic setting

Cut-in conditions:

- The handbrake must be active
- The engine is running
- The gearbox must be in neutral
- The engine speed is lower than Nmax cut-in (650 rpm)
- The vehicle speed is lower than 1.5 km/h

Cut-out conditions:

- The handbrake must be de-activated
- The engine is not running
- The vehicle contact is switched off
- The vehicle speed is higher than 1.5 km/h

Gear-shift commands are not carried out during PTO operation.

Operation of PTO on a moving vehicle should be activated using the diagnostic tool (DAVIE XD)

Cut-in conditions:

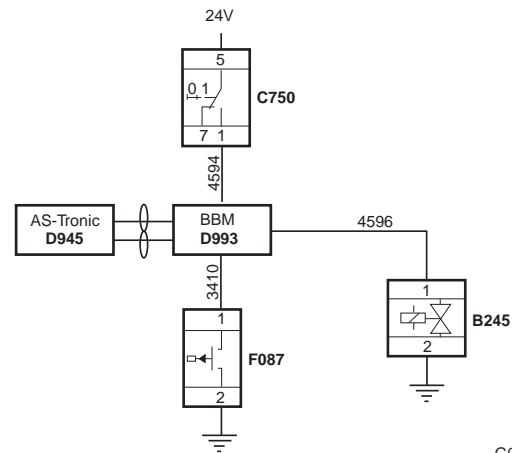

G001198-1

- The handbrake must be active
- The engine is running
- The gearbox must be in neutral
- The engine speed is lower than Nmax cut-in (650 rpm)
- The vehicle speed is lower than 1.5 km/h

Cut-out conditions:

- The engine is not running
- The vehicle contact is switched off

Changing gear during driving is not possible. So when driving off, the gear eventually required during driving should already be engaged!

Note:

AS-Tronic software version may limit instationary PTO use, to 1st and RL gear with direct drive gearboxes and to 2nd and RH gear with overdrive gearboxes. No gearchange possible with these versions. Check the vehicle configuration on this in case instationary PTO use is required.

Depending on the situation, the PTO warning is given between 2 and 5 seconds after a defect or undesirable situation occurs.

Note:

When the PTO is engaged, programmed to instationary use, and crawler gears are selected:

- As lowest gearing, gears 1 and RL are available for Direct Drive (DD) gearboxes
- As lowest gearing, gears 2 and RH are available for Over Drive (OD) gearboxes

Activation of PTO control via CAN message PropB_CXB

In addition to engage the PTO via the hardwired option, it is also possible, providing selection code 9562 "with application connector body builder CAN" has been chosen, to activate this via CAN. To be able to use this functionality, the body must provide CAN message PropB_CXB with identifier 18_FF_80_E6 to pin 17 and 18 of connector 12D. The data that must be provided in this message is as follows:

Signal name	Byte	Bit	Type	Offset	Min	Max	Unit	Comments
CXB Remote PTO 1	3	2,1	Status	-	0	3	-	00 _b =passive 10 _b =error 01 _b =active 11 _b =not available
CXB Remote PTO 2	3	4,3	Status	-	0	3	-	00 _b =passive 10 _b =error 01 _b =active 11 _b =not available

BODYBUILDERS' GUIDELINES

Electrical system XF series

PTO hour counter(s)

As is clear from the above, vehicles can be equipped with one or more PTO's. The function of the PTO hour counter is to record the number of additional engine operating hours during PTO operation, and if possible, to take them into account when determining the vehicle's maintenance intervals. Readout of the number of PTO hours is via the DOT matrix display using the menu control switch on the dashboard (DIP) or via DAVIE. The operating time (in hours) of a maximum of 2 PTO's can be read out via the display. If PTO1 is switched on, the operating time is automatically added to the total for PTO1. When PTO2 is switched on, the operating time is automatically added to the total for PTO2. Both PTO1 and PTO2 can be reset using DAVIE. The PTO counters will become visible after more than 1 minute operation.

A separate hour counter is available as analogue gauge. See chapter 8.5: "CVSG type gauges".

Customer parameter list

In the next tables all related customer parameters are listed.

Customer parameter ID ⁽¹⁾	Customer parameter name	System	Value
	PTO-1/2 switch on conditions		
1-01 / 1-45	PTO 1/2 ON - brake valid	BBM	ACTIVE / NOT ACTIVE
1-02 / 1-46	PTO 1/2 ON - brake use	BBM	PRESSED / RELEASED
1-03 / 1-47	PTO 1/2 ON - clutch valid	BBM	ACTIVE / NOT ACTIVE
1-04 / 1-48	PTO 1/2 ON - clutch use	BBM	PRESSED / RELEASED
1-05 / 1-49	PTO 1/2 ON - park brake valid	BBM	ACTIVE / NOT ACTIVE
1-06 / 1-50	PTO 1/2 ON - park brake use	BBM	APPLIED / RELEASED
1-07 / 1-51	PTO 1/2 ON - engine running valid	BBM	ACTIVE / NOT ACTIVE
1-08 / 1-52	PTO 1/2 ON - engine running use	BBM	RUNNING / NOT RUNNING
1-09 / 1-53	PTO 1/2 ON - maximum engine speed	BBM	Rpm
1-10 / 1-54	PTO 1/2 ON - maximum vehicle speed	BBM	km/h
1-88	PTO 1 ON - minimum engine speed	BBM	Rpm
1-89	PTO 1 ON - pressure switch	BBM	ACTIVE / NOT ACTIVE

(1) For changing default parameter settings see chapter 7.19: "Guideline for the Customer Parameter Change Form"

BODYBUILDERS' GUIDELINES

Electrical system XF series

Customer parameter ID ⁽¹⁾	Customer parameter name	System	Value
	PTO-1/2 switch off conditions		
1-12 / 1-55	PTO 1/2 OFF - brake valid	BBM	ACTIVE / NOT ACTIVE
1-13 / 1-56	PTO 1/2 OFF - brake use	BBM	PRESSED / RELEASED
1-14 / 1-57	PTO 1/2 OFF - clutch valid	BBM	ACTIVE / NOT ACTIVE
1-15 / 1-58	PTO 1/2 OFF - clutch use	BBM	PRESSED / RELEASED
1-16 / 1-59	PTO 1/2 OFF - park brake valid	BBM	ACTIVE / NOT ACTIVE
1-17 / 1-60	PTO 1/2 OFF - park brake use	BBM	APPLIED / RELEASED
1-18 / 1-61	PTO 1/2 OFF - engine running valid	BBM	ACTIVE / NOT ACTIVE
1-19 / 1-62	PTO 1/2 OFF - engine running use	BBM	RUNNING / NOT RUNNING
1-20 / 1-63	PTO 1/2 OFF - maximum engine speed	BBM	Rpm
1-21 / 1-64	PTO 1/2 OFF - maximum vehicle speed	BBM	km/h

(1) For changing default parameter settings see chapter 7.19: "Guideline for the Customer Parameter Change Form"

Customer parameter ID ⁽¹⁾	Customer parameter name	System	Value
	PTO-1/2 other		
1-31 / 1-65	PTO 1/2 Type	BBM	STATIONARY / IN-STATIONARY / ENGINE
1-34 / 1-66	PTO 1/2 On Timeout	BBM	Milliseconds
1-35 / 1-67	PTO 1/2 Off Timeout	BBM	Milliseconds
1-91	PTO 1 OFF Time	BBM	Milliseconds

(1) For changing default parameter settings see chapter 7.19: "Guideline for the Customer Parameter Change Form"

11

BODYBUILDERS' GUIDELINES

Electrical system XF series

Customer parameter ID ⁽¹⁾	Customer parameter name	System	Value
	AStronic PTO-1/2 switch on conditions		
1-68 / 1-76	PTO 1/2 ON - park brake valid	BBM	ACTIVE / NOT ACTIVE
1-69 / 1-77	PTO 1/2 ON - park brake use	BBM	APPLIED / RELEASED
1-70 / 1-78	PTO 1/2 ON - maximum engine speed	BBM	Rpm
1-71 / 1-79	PTO 1/2 ON - maximum vehicle speed	BBM	km/h

(1) For changing default parameter settings see chapter 7.19: "Guideline for the Customer Parameter Change Form"

Customer parameter ID ⁽¹⁾	Customer parameter name	System	Value
	AStronic PTO-1/2 switch off conditions		
1-73 / 1-81	PTO 1/2 OFF - park brake valid	BBM	ACTIVE / NOT ACTIVE
1-74 / 1-82	PTO 1/2 OFF - park brake use	BBM	APPLIED / RELEASED
1-32 / 1-83	PTO 1/2 OFF - maximum engine speed	BBM	Rpm
1-75 / 1-84	PTO 1/2 OFF - maximum vehicle speed	BBM	km/h

(1) For changing default parameter settings see chapter 7.19: "Guideline for the Customer Parameter Change Form"

Customer parameter ID ⁽¹⁾	Customer parameter name	System	Value
	AStronic PTO-1/2 other		
1-31 / 1-65	PTO 1/2 Type	BBM	STATIONARY / IN-STATIONARY / ENGINE
1-33 / 1-85	AStronic PTO 1/2/ Time		Milliseconds
1-34 / 1-66	PTO 1/2 On Timeout	BBM	Milliseconds
1-35 / 1-67	PTO 1/2 Off Timeout	BBM	Milliseconds

(1) For changing default parameter settings see chapter 7.19: "Guideline for the Customer Parameter Change Form"

Customer parameter ID ⁽¹⁾	Customer parameter name	System	Value
	Remote engine start/stop PTO-1/2 control		
1-118	Remote engine start/stop PTO 1 control	BBM	ENABLED / DISABLED
1-119	Remote engine start/stop PTO 2 control	BBM	ENABLED / DISABLED

(1) For changing default parameter settings see chapter 7.19: "Guideline for the Customer Parameter Change Form"

11.17 XF SERIES TRAILER CONNECTION POINTS

The electric trailer connection consists of possibly three 7-pin and one fifteen pin sockets. For details see the information in the CF series chapter 10.15: "CF series trailer connection points".

BODYBUILDERS' GUIDELINES

Electrical system XF series

APPLICATION CONNECTOR (CODE) NUMBER LIST

	Page	Date
12.1 Connector 1M spare wiring	355	201019
12.2 Connector 1P RAS-EC system	356	201019
12.3 Connector 3C engine torque limiter	356	201019
12.4 Connector 3L accessoires	357	201019
12.5 Connector 3P ESC system	358	201019
12.6 Connector 4C ESC system	359	201019
12.7 Connector 4D PTO control system	361	201019
12.8 Connector 4V refuse collector	362	201019
12.9 Connector 5V refuse collector	363	201019
12.10 Connector 6V refuse collector	363	201019
12.11 Connector 12D body builder	364	201019
12.12 Connector 23K body functions	366	201019
12.13 Connector 56A accessories	367	201019
12.14 Connector 56W refuse collector	368	201019
12.15 Connector 182C power supply	369	201019
12.16 Connector 183C power supply	369	201019
12.17 Connector 238C radio system	370	201019
12.18 Connector A000 trailer system (ISO1185 type 24N)	371	201019
12.19 Connector A001 trailer system (ISO3731 type 24S)	372	201019
12.20 Connector A004 trailer system (ISO7638)	373	201019
12.21 Connector A007 accessories 24V 2-pole	373	201019
12.22 Connector A011 accessories 12V 2-pole	374	201019
12.23 Connector A038 accessories	374	201019
12.24 Connector A043 driver seat connector	375	201019
12.25 Connector A058 trailer system (ISO12098)	376	201019
12.26 Connector A068 (chassis - ESC system)	377	201019
12.27 Connector A070 accessories 8-pole)	379	201019
12.28 Connector A076 telephone	379	201019
12.29 Connector A088 taillift system 7-pole	380	201019
12.30 Connector A095 application refuse collector	381	201019
12.31 Connector A097 FMS system	383	201019
12.32 Connector A098 FMS system	384	201019
12.33 Connector A100 HD-OBD diagnose	385	201019
12.34 Connector A102 body builder 8-pole	386	201019
12.35 Connector A103 bodybuilder 12-pole	387	201019
12.36 Connector A104 spare wiring 18-pole	388	201019
12.37 Connector A105 Bodybuilder CAN system 7-pole	389	201019
12.38 Connector A106 CAN-cab 9-pole	389	201019
12.39 Connector A113 garbage truck	390	201019
12.40 Connector A117 trailer 13-pole	391	201019
12.41 Connector A122 hydraulic platform 9-pole	392	201019
12.42 Connector A123 hydraulic platform 21-pole	393	201019
12.43 Connector A125 hydraulic platform feed through	394	201019
12.44 Connector A126 FMS 2-pole	395	201019
12.45 Connector A134 refuse feed through wire	396	201019
12.46 Connector A138 FMS 12-pole	397	201019
12.47 Connector A139 - A140 extra camera	397	201019
12.48 Connector D318 (ECU) Toll Collect	398	201019
12.49 Connector D365.A - D365.B radio system	399	201019
12.50 Connector D347.A - D347.B radio system	400	201019
12.51 ECN code number overview	400	201019

BODYBUILDERS' GUIDELINES

Application connector (code) number list

12.APPLICATION CONNECTOR (CODE) NUMBER LIST

12.1 CONNECTOR 1M SPARE WIRING

Pin	Wire	Description	Active Low ⁽¹⁾ Active High ⁽²⁾	Pin on ECN code
1	X003	Spare wire to dasboard switch 1		
2	X004	Spare wire to dasboard switch 2		
3	X005	Spare wire to dasboard switch 3		
4	X006	Spare wire to dasboard switch 4		
5	X007	Spare wire to header shelf switch 1		
6	X008	Spare wire to header shelf switch 2		
7	X009	Spare wire to header shelf switch 3		
8	X010	Spare wire to header shelf switch 4		

(1) Active low: function is activated if pin is grounded.

(2) Active high: function is activated if pin is connected to battery plus (12 V minimum).

See section 9.2: "LF series bulkhead connections" for more information about the location of this connector.

See section 9.5: "LF series accessories connection dashboard" for more information about the body function connections in the dashboard of LF vehicles.

See section 9.4: "LF series accessories connection headershell" for more information about the body function connections in the headershell of LF vehicles.



NOTE: 1M = 8 pole grey connector,

BODYBUILDERS' GUIDELINES

Application connector (code) number list

12.2 CONNECTOR 1P RAS-EC SYSTEM

Pin	Wire	Description	Active Low ⁽¹⁾ Active High ⁽²⁾	Pin on ECN code
1				
2				
3				
4				
5	3514	Vehicle speed	-	D525:B07
5				
6				
7				
8				

(1) Active low: function is activated if pin is grounded.

(2) Active high: function is activated if pin is connected to battery plus (12 V minimum).

See section 9.2: "LF series bulkhead connections" for more information about the location of this connector.



NOTE: 1P = Brown colored connector.

12.3 CONNECTOR 3C ENGINE TORQUE LIMITER

Connector 3C

Pin	Wire	Description	Active low ⁽¹⁾ Active High ⁽²⁾	Pin on ECN code
1	3701	VCAN1 High		D965: B45
2	3700	VCAN1 Low		D965: B53
3	6185	Torque limiter	AH/AL	D965: B08
4	4605	Trailer Brake	AH	D965: B51
5	-			
6	6186	Torque limiter	AH/AL	D965: B11

(1) Active low: function is activated if pin is grounded.

(2) Active high: function is activated if pin is connected to battery plus (12 V minimum).

See section 10.2: "CF series bulkhead connection overview" for more information about the ESC system available on CF75-85 and XF vehicles.

12.4 CONNECTOR 3L ACCESSOIRES

Bulkhead connection 3L

Pin	Wire	Description	Active Low ⁽¹⁾ Active High ⁽²⁾	Pin on ECN code
B2	3660	12V power supply Cargo interior detection sensor		D911: B04
B3	4721	Gearbox Neutral switch	AL	D358: B15
B6	3651	12V power supply ultrasonic sensor		D911: A10

(1) Active low: function is activated if pin is grounded.

(2) Active high: function is activated if pin is connected to battery plus (12 V minimum).



*NOTE: 3L = Brown 16-pole connector
Connectors and signals available are
depending on vehicle options chosen.
Make sure that the correct SELCO's are
used when ordering the vehicle, in
order to assure functionality.*

See section 9.2: "LF series bulkhead connections" for more information about the location of this connector.

BODYBUILDERS' GUIDELINES

Application connector (code) number list

12.5 CONNECTOR 3P ESC SYSTEM

Bulkhead 3P lead-through for engine speed control

Selection code 0797: Cab Connector 3P				
Pin	Wire	Description	Active low ⁽¹⁾ Active high ⁽²⁾	Pin on ECN code
A1	3524	PTO1 Status	AL	D358L: C30
A2	4596	PTO1 Solenoid	AH	D358L: B23
A3	3143	ESC enable	AH	D358L: D09
A4	3144	ESC N1 / N_variable	AH	D358L: D05
A5	3145	ESC N2 / Set +	AH	D358L: D06
A6	3146	ESC N3 / Set -	AH	D358L: D07
A7	M	Ground (KL31)	-	-
A8	-	-	-	-
B1	3412	Cab lock	AL	D942: B08
B2	3157	Engine running	AH	D358L: C42
B3	3420	Remote PTO	AH	D358L: C17
B4	5280	Remote engine start (only with BBM)	AH	D993 - D08
B5	3848	Remote engine stop (only with BBM)	AH	D993 - C16
B6	3878	CVSG data (only with BBM)	-	D993 - D11
B7	2161	Power supply (KL15)	-	G188: 87
B8	1600	Power supply (KL30)	-	D942: B08

(1) Active low: function is activated if pin is grounded.

(2) Active high: function is activated if pin is connected to battery plus (12 V minimum).

See section 9.2: "LF series bulkhead connections" for more information about the location of this connector.

See section 9.5: "LF series accessories connection dashboard" for more information about the body function connections in the dashboard of LF vehicles.

See section 9.4: "LF series accessories connection headershell" for more information about the body function connections in the headershell of LF vehicles.



NOTE: 3P = Blue 16 pole connector

12.6 CONNECTOR 4C ESC SYSTEM

Cab Connector 4C (Selection code 0797)

DAF-DMCI variant (CF75-85 and XF series)

Pin	Wire	Description	Active low ⁽¹⁾ Active high ⁽²⁾	Pin on ECN code
1	M37	Ground (KL31)	-	-
2	3848	Engine Stop (+24V signal)	AH	D993: C16
3	3003	Engine speed output signal	AL ⁽³⁾	D993: D05
4	3039	Vmax special application	AH	D993: C17
5	3141	Set + Esc	AH	D993: C19
6	3142	Set - Esc	AH	D993: C18
7	3143	ESC enable	AH	D993: C20
8	3144	N Variable	AH	D993: C21
9	3145	ESC N2	AH	D993: D06
10	3146	ESC N3	AH	D993: D07
11	5280	Remote Engine start	AH	D993: D08
12	1240	Power supply (KL15)	-	-

(1) Active low: function is activated if pin is grounded.

(2) Active high: function is activated if pin is connected to battery plus (12 V minimum).

(3) This engine speed signal corresponds to 30 pulses per crankshaft revolution. A "Pull Up" resistor must be fitted in accordance with Figure A.

See section 10.2: "CF series bulkhead connection overview" for more information about the location of this connector.

See section 10.16: "CF75 - CF85 ESC system" for more information about the ESC system available on CF75-85 and XF vehicles.

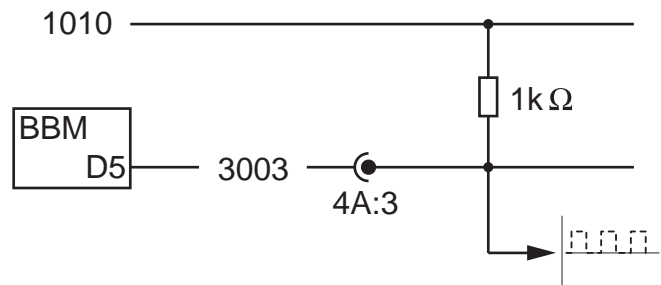

G000545

Figure A: location of "Pull Up" resistor

BODYBUILDERS' GUIDELINES

Application connector (code) number list

Bulkhead lead-through for engine speed control (connector code 4C)

PACCAR-Cummins variant (CF65 series)

Pin	Wire	Description	Active low ⁽¹⁾ Active high ⁽²⁾	Pin on ECN code
1	M37	Ground (KL31)	-	-
2	3848	Remote Engine stop	AH	D993: C16
3	3003	Engine speed output signal	AL ⁽³⁾	D993: D05
4	3039	Vmax application	AH	D993: C17
5	3141	No function	AH	D993: C19
6	3142	No function	AH	D993: C18
7	3143	Engine speed control enable	AH	D993: C20
8	3144	ESC N1	AH	D993 C21
9	3145	ESC N2	AH	D993: D06
10	3146	ESC N3	AH	D993: D07
11	5280	No function	AH	D993: D08
12	1240	Power supply (KL15)	-	-

(1) Active low: function is activated if pin is grounded.

(2) Active high: function is activated if pin is connected to battery plus (12 V minimum).

(3) This engine speed signal corresponds to 30 pulses per crankshaft revolution. A "Pull Up" resistor must be fitted in accordance with Figure A.



WARNING! All signals mentioned in the tables explaining application connector pinning are active +24V (HS = High Side) and inactive open or 0V (LS = Low Side) unless stated otherwise!

See section 10.2: "CF series bulkhead connection overview" for more information about the location of this connector.

See section 10.13: "CF65 series ESC system" for more information about the ESC system available on CF65 vehicles.

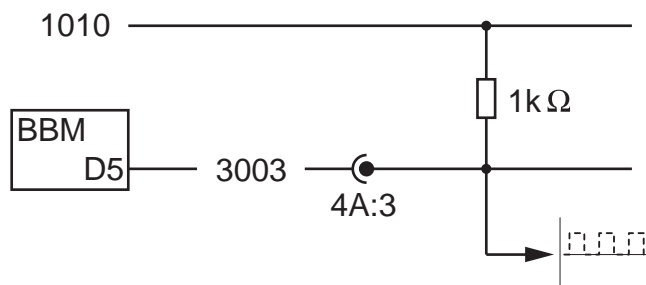

G000545

Figure A: location of "Pull Up" resistor

12.7 CONNECTOR 4D PTO CONTROL SYSTEM

Connector 4D (PTO control system)

Pin	Wire	Description	Active low ⁽¹⁾ Active high ⁽²⁾	Pin on ECN code
1	M39	Ground (KL31)		-
2	4594	Remote control PTO-1	AH	D993: C07
3	3410	PTO-1 status and indication on outside panel	AL	D993: C10
4	4596	PTO-1 valve	AH	B245: 01
5	3668	PTO-2 status and indication on outside panel (not for CF65)	AL	D993: C11
6	3878	CVSG gauges Databus connection		D993: D11
7	3745	PTO-3	AL	F117: 01
8	6157	PTO-3 valve	AH	B405: 01
9	4595/ 5149	PTO-2 valve	AH	B246: A01
10	3798	PTO- warning		D993: D03
11	5241	Remote control PTO-2 (not for CF65)	AH	D993: C08
12	5462	12V for CVSG gauges		A124: 01

(1) Active low: function is activated if pin is grounded.

(2) Active high: function is activated if pin is connected to battery plus (12 V minimum).

See section 10.2: "CF series bulkhead connection overview" for more information about the location of this connector.

See section 10.18: "CF series PTO control / protection" for more information about the PTO control system available on CF vehicles.



WARNING! All signals mentioned in the tables explaining application connector pinning are active +24V (HS = High Side) and inactive open or 0V (LS = Low Side) unless stated otherwise!

BODYBUILDERS' GUIDELINES

Application connector (code) number list

12.8 CONNECTOR 4V REFUSE COLLECTOR

Pin	Wire	Description	BBM Pin INPUT / OUTPUT	Active Low ⁽¹⁾ Active High ⁽²⁾	Related CP in BBM unit
1	3215	PTO ACTIVE Gives the status signal of PTO-1 from chassis	D21 OUTPUT	AH	tbd
2	3211	HIGH RPM REQUEST Request signal from the superstructure to activate high RPM	D24 INPUT	AH	tbd
3	3039	FOOTBOARD PROTECTION / Vmax APPLICATION SPEED When this input is high, and gearbox is switched into reverse, engine stop and park brake becomes active. When this input is high, "Vmax application" will be active when Gearbox in Drive.	C17 INPUT	AH / AL ⁽³⁾	--
4	3249	DRIVE LINE ENGAGED If the output of the function gearbox state is drive line engaged.	D22	AH	
5	--	--	--	--	--
6	4591	REVERSE INDICATOR Active when gearbox is switched into reverse (relay G350).	C09 INPUT	AH	
7	3248	REVERSE GEAR INDICATOR Active when reverse gear is engaged (relay G350)	D36	AH	
8	3402	PARK BRAKE ACTIVE Active when park brake is engaged	D310 lite - C30	n/a	

(1) AL = Active Low: function is activated if pin is grounded.

(2) AH = Active High: function is activated if pin is connection to battery plus (12V minimum).

(3) Fault detection on pin C17 depending on footboard switch.

See section 9.2: "LF series bulkhead connections" for more information about the location of the refuse connector on LF vehicles.

See section 9.13: "Refuse preparation LF Series" for more information on the refuse collector system on LF vehicles.

12.9 CONNECTOR 5V REFUSE COLLECTOR

Pin	Wire	Description	BBM Pin INPUT / OUTPUT	Active Low (1) Active High (2)	Related CP in BBM unit
1	1600	KL30 10A Power supply 24V before contact - Fuse E290 Other consumers also fed via this power supply.	--	--	tbd
2	1600	KL30 10A Power supply 24V before contact - Fuse E290. Other consumers also fed via this power supply.	--	--	tbd
3	--	--	--	--	tbd
4	5439	Park Brake Control	--	--	tbd

(1) AL = Active Low: function is activated if pin is grounded.

(2) AH = Active High: function is activated if pin is connection to battery plus (12V minimum).

See section 9.2: "LF series bulkhead connections" for more information about the location of the refuse connector on LF vehicles.

See section 9.13: "Refuse preparation LF Series" for more information on the refuse collector system on LF vehicles.

12.10 CONNECTOR 6V REFUSE COLLECTOR

Pin	Wire	Description	BBM Pin INPUT / OUTPUT	Active Low (1) Active High (2)	Related CP in BBM unit
1	M	Ground	--	--	tbd
2	M	Ground	--	--	tbd
3	2161	KL15 15A. Power supply 24V after contact - Fuse E156. Other consumers also fed via this power supply.	--	--	tbd
4	2161	KL15 15A. Power supply 24V after contact - Fuse E156. Other consumers also fed via this power supply.	--	--	tbd

(1) AL = Active Low: function is activated if pin is grounded.

(2) AH = Active High: function is activated if pin is connection to battery plus (12V minimum).

BODYBUILDERS' GUIDELINES

Application connector (code) number list

See section 9.2: "LF series bulkhead connections" for more information about the location of the refuse connector on LF vehicles.

See section 9.13: "Refuse preparation LF Series" for more information on the refuse collector system on LF vehicles.

12.11 CONNECTOR 12D BODY BUILDER

Selection code 9562: Cab Connector 12D				
Pin	Wire	Description	Active low ⁽¹⁾ Active high ⁽²⁾	Pin on ECN code
1	M40	Ground (KL31)	-	A102: 7
2	M98	Ground (KL31)	-	A102: 8
3	3412	Cab lock	AL	A102: 4
4	3809	Enable CAN open	AL	A105/A106: 3
5	3772	FMS	-	A098:4
6	6164	Power supply Taillift	-	A088:7
7	6165	Relay G466, Taillift open, pin B5	-	A088:2
8	6166	Relay G466, Taillift open, pin B4	-	A088:3
9	6167	taillift "Standby for Use" signal	-	A088:1
10	6168	Relay G466, Taillift open, pin B1	-	A088:5
11	6169	Relay G466, Taillift open, pin B2	-	A088:6
12	A8	Reserve radio recess	-	A104:8
13	A9	Reserve radio recess	-	A104:9
14	A10	Reserve radio recess	-	A104:10
15	A11	Reserve radio recess	-	A104:11
16	3842	BB_CAN_Ground	-	D993: D09
17	3810	BB_CAN_Low	-	D993: D19
18	3811	BB_CAN_High	-	D993: D17
19	3157	Engine running signal	AH	D358: C42
20	1154	Power supply (KL30)	-	A102: 1
21	1258	Power supply (KL15)	-	A102: 2

(1) Active low: function is activated if pin is grounded.

(2) Active high: function is activated if pin is connected to battery plus (12 V minimum).

See section 10.2: "CF series bulkhead connection overview" for more information about the ESC system available on CF75-85 and XF vehicles.

See section 10.5: "CF series accessories connection in dashboard" for more information about the reserve connector A104 behind the radio recess panel in the on CF75-85 and XF vehicles.

See section 10.18: "CF series PTO control / protection" for more information about the location of this connector.



WARNING! All signals mentioned in the tables explaining application connector pinning are active +24V (HS = High Side) and inactive open or 0V (LS = Low Side) unless stated otherwise!

BODYBUILDERS' GUIDELINES

Application connector (code) number list

12.12 CONNECTOR 23K BODY FUNCTIONS

Bulkhead connection 23K

Pin	Wire	Description	Active Low ⁽¹⁾ Active High ⁽²⁾	Pin on ECN code
A1	3503	Fuel level		D358L: D12
A2	3402	Park brake signal	AH	D358L: B05
A3	5104	Reverse buzzer switch	AL	C880: 5
A4	4517	Switch cross lock	AH	C748: 1
A5	1665	Power supply (KL15)		D942: B03
A6				
A7	1217	Power supply (KL15)		D942: P08
A8	2036	Direction trailer left		D358L: A07
A9	2037	Direction trailer right		D358L: A08
A10	2170	Light rear left	AH	C201: 2
A11	2169	Light rear right	AH	C202: 2
A12	2152	Rear fog lights		G005: A03
A13	4601	Brake signal	AH	D942: A07
B1	1356	Power supply (KL15)		D942: L02
B2	4591	Reversing alarm signal	AH	D942: A05
B3	1110	Power supply (KL30)		D942: A08
B4	1240	Power supply (KL15)		G353: 87
B5	5051	Fuel heater	AH	G201: 87
B6	3659	Cargo Door Alarm	AL	D911: B06
B7	2008	Direction indicator rear left		D358L: E07
B8	2009	Direction indicator rear right		D358L: E04
B9	3408	Differential lock		D358L: C34
B10	3428	ABS/EBS trailer		D358L: C32
B11	3412	Cabin Lock	AH	D358L: B16
B12	2155	Body interior lighting	AH	D358L: C09

(1) Active low: function is activated if pin is grounded.

(2) Active high: function is activated if pin is connected to battery plus (12 V minimum).



NOTE: 23K = Yellow 25-pole connector,
Connectors and signals available are depending on vehicle options chosen.
Make sure that the correct SELCO's are used when ordering the vehicle, in order to assure functionality.

See section 9.2: "LF series bulkhead connections" for more information about the location of this connector.

12.13 CONNECTOR 56A ACCESSORIES

Bulkhead lead-through for accessories

Pin	Wire	Description	Active Low ⁽¹⁾ Active High ⁽²⁾	Pin on ECN code
1	9094	Ground EBS trailer		A004: 3
2	9088	Ground CAN line		A058: 13
3	2008	Direction indicator trailer left	AH	D358: A07
4	2009	Direction indicator trailer right	AH	D358: A08
5	2102	Marker light left	AH	D787: A33
6	2103	Marker light right	AH	D787: A28
7	2152	Rear fog lamp	AH	D878: A24
8	2155	Body interior lighting / worklamp cab rear	AH	G462: C01
9	4591	Reversing signal	AH	G350: D23
10	4601	Brake signal	AH	G036: C08
11	3812	CAN 11992/3 low TT-CAN		D993: D13
12	3813	CAN 11992/3 low TT-CAN		D993: D12
13	3651	12V supply ultrasonic sensor		D911: A10
14	3659	Cargo door	AL	D911: B06
15	3660	Cargo interior	AL	D911: B04
16	3428	EBS trailer warning	AL	D878: D35
17	3558	Trailer CAN 11992/2 low		D977: B03
18	3559	Trailer CAN 11992/2 high		D977: B06
19				
20	1390	Power supply (KL15)		A004: 2
21	1113	Power supply (KL30)		D878: C16

(1) Active low: function is activated if pin is grounded.

(2) Active high: function is activated if pin is connected to battery plus (12 V minimum).

See section 10.2: "CF series bulkhead connection overview" for more information about the location of this connector.



WARNING! All signals mentioned in the tables explaining application connector pinning are active +24V (HS = High Side) and inactive open or 0V (LS = Low Side) unless stated otherwise!

BODYBUILDERS' GUIDELINES

Application connector (code) number list

12.14 CONNECTOR 56W REFUSE COLLECTOR

Refuse preparation connector 56W

Pin	Wire	Description	BBM Pin INPUT / OUTPUT	Active Low (1) Active High (2)	Related CP in BBM unit
1	3412	Unlatched cabin Active at open cabin lock (except at fully turned over cabin)	F009	AH	tbd
2	--	--	--	--	--
3	3238	ENGINE RUNNING Active when engine speed > nhhhh400 RPM. Output signal 24V.	A08	AH	--
4	3215	VEHICLE SPEED >5 KM/H Active when vehicle > 5 km/h.	D31	AH	--
5	3214	VEHICLE SPEED >10 KM/H Active when vehicle > 10 km/h.	D32	AH	--
6	3212	ENGINE SPEED >1400 RPM Active when engine speed > 1400 RPM.	D23	AH	--
7	3210	BODY ACTIVE body active signal from superstructure. 24V input.	C12	AH	--
8	3213	BODY RELEASE Active if body active signal is high and all switch on conditions are met.	D34	AH	--

(1) AL = Active Low: function is activated if pin is grounded.

(2) AH = Active High: function is activated if pin is connection to battery plus (12V minimum).

See section 9.2: "LF series bulkhead connections" for more information about the location of the refuse connector on LF vehicles.

See section 9.13: "Refuse preparation LF Series" for more information on the refuse collector system on LF vehicles.

12.15 CONNECTOR 182C POWER SUPPLY

9-pin econoseal (black)

Pin	Wire	Description	Active Low ⁽¹⁾ Active High ⁽²⁾	Pin on ECN code
1	1107	Power supply (KL30)	AL	C960:7
2	1258	Power supply (KL15)		G763: B1
3	5444	Speaker telematics (plus)	AH	D324: A16
4	2630	Switch search light supply	AH	Various
5	2649	Spotlight switched return	AH	C244: 7
6	5445	Speaker Telematics	AL	L036: D1
7	5399	Telephone speaker	AH	L036: 2A1
8	5418	Telephone speaker	AL	L036: B1
9	M52	Ground (KL31)		

(1) Active low: function is activated if pin is grounded.

(2) Active high: function is activated if pin is connected to battery plus (12 V minimum).

See section 10.4: "CF series accessories connections" for more information about the location of this connector.

12.16 CONNECTOR 183C POWER SUPPLY

12-pin econoseal (black)

Pin	Wire	Description	Active Low ⁽¹⁾ Active High ⁽²⁾	Pin on ECN code
1	1154	Power supply (KL30)		
2	1258	Power supply (KL15)		
3	1101	Power supply (KL30)		
4	2630	Search light switches	AH	Various
5	2102	Tail light, left signal	AH	A058: 5
6	2122	Signal, main beam	AL	C927: 5
7	2216	High lights / spot lights signal	AH	C927: 7
8	M70	Ground (KL31)		
9	-			
10	-			
11	M668	Ground (KL31)		
12	5270	Buzzer door open / parking brake not applied	AH	B330: A1

(1) Active low: function is activated if pin is grounded.

(2) Active high: function is activated if pin is connected to battery plus (12 V minimum).

BODYBUILDERS' GUIDELINES

Application connector (code) number list

See section 10.4: "CF series accessories connections" for more information about the location of this connector.

12.17 CONNECTOR 238C RADIO SYSTEM

Pin	Wire	Description	Active Low ⁽¹⁾ Active High ⁽²⁾	Pin on ECN code
1				
2				
3				
4	1363	Power supply (KL15)		A076: 1
5				
6				
7	1108	Power supply (KL30)		A076: 2
8	M469	Ground (KL31)		A076: 3

(1) Active low: function is activated if pin is grounded.

(2) Active high: function is activated if pin is connected to battery plus (12 V minimum).

See section 10.7: "CF series radio preparation" for more information about the location available on CF and XF vehicles.

12.18 CONNECTOR A000 TRAILER SYSTEM (ISO1185 TYPE 24N)

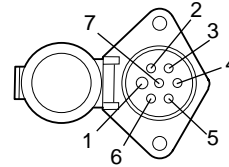

22032802-007

7 pin connector; light system

Pin	Wire	Description	Active Low ⁽¹⁾ Active High ⁽²⁾	Pin on ECN code
1	M133	Ground (KL31)		
2	2102	Tail light and contour lighting, left, and number plate light	AH	D878: A33
3	2008	Direction indicator, left	AL	D358: A07
4	4601	Brake lights	AH	G036: C08
5	2009	Direction indicator, right	AL	D358: A08
6	2103	Tail light and contour lighting, right. and number plate light	AH	D878: A28

(1) Active low: function is activated if pin is grounded.

(2) Active high: function is activated if pin is connected to battery plus (12 V minimum).

See section 9.14: "LF series trailer connection points" for the function of this connector on LF vehicles.

See section 10.15: "CF series trailer connection points" for the function of this connector on CF and XF vehicles.

BODYBUILDERS' GUIDELINES

Application connector (code) number list

12.19 CONNECTOR A001 TRAILER SYSTEM (ISO3731 TYPE 24S)

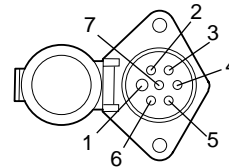

22032802-007

7 pin connector; accessories

Pin	Wire	Description	Active Low ⁽¹⁾ Active High ⁽²⁾	Pin on ECN code
1	M132	Ground (KL31)		
2	3659	Cargo door alarm system (Note: not connected on LF vehicles)	AL	D911: B06
3	4591	Reversing lights	AH	D878: D23
4	1113	Power supply (KL30)		D878: C16
5	3660	Cargo Internal alarm system (Note: not connected on LF vehicles)	AL	D911: B04
6	3651	power supply alarm system		D911: A10
7	2152	Rear fog lamp	AH	D878: A24

(1) Active low: function is activated if pin is grounded.

(2) Active high: function is activated if pin is connected to battery plus (12 V minimum).

See section 9.14: "LF series trailer connection points" for the function of this connector on LF vehicles.

See section 10.15: "CF series trailer connection points" for the function of this connector on CF and XF vehicles.

12.20 CONNECTOR A004 TRAILER SYSTEM (ISO7638)

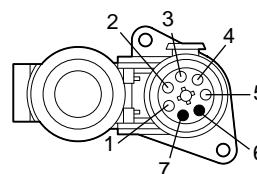

20090503-005

7 pin connector; ABS / EBS system

Pin	Wire	Description	Active Low ⁽¹⁾ Active High ⁽²⁾	Pin on ECN code
1	1119	Power supply (KL30)		
2	1390	Control		
3	9094	Ground (KL31)		
4	9090	Ground (KL31)		
5	3428	Information		D878: D35
6	3559	CAN 11992 EBS ONLY		D977: B06
7	3558	CAN 11992 EBS ONLY		D977: B03

(1) Active low: function is activated if pin is grounded.

(2) Active high: function is activated if pin is connected to battery plus (12 V minimum).

See section 9.14: "LF series trailer connection points" for the function of this connector on LF vehicles.

See section 10.15: "CF series trailer connection points" for the function of this connector on CF and XF vehicles.

12.21 CONNECTOR A007 ACCESSORIES 24V 2-POLE

Connector accessories 24V

Pin	Wire	Description	Active Low ⁽¹⁾ Active High ⁽²⁾	Pin on ECU
1	M683	Ground (KL31)	-	-
2	1103	Power supply (KL15)	-	D878: C35

(1) Active low: function is activated if pin is grounded.

(2) Active high: function is activated if pin is connected to battery plus (12 V minimum).

See section 7.13: "Connection points and permitted power loads" for the maximum load permitted on this connector.

See section 10.1: "CF series cab switch and connector locations" for the location of this connector.

BODYBUILDERS' GUIDELINES

Application connector (code) number list

See section 11.1: "XF series cab switch and connector locations" for the location of this connector.

12.22 CONNECTOR A011 ACCESSORIES 12V 2-POLE

Connector accessoire 12V

Pin	Wire	Description	Active Low ⁽¹⁾ Active High ⁽²⁾	Pin on ECU
1	M31	Ground (KL31)	-	-
2	1311	Power supply (KL30)	-	D330: A4

(1) Active low: function is activated if pin is grounded.

(2) Active high: function is activated if pin is connected to battery plus (12 V minimum).

See section 7.13: "Connection points and permitted power loads" for the maximum load permitted on this connector.

See section 10.1: "CF series cab switch and connector locations" for the location of this connector.

See section 11.1: "XF series cab switch and connector locations" for the location of this connector.

12.23 CONNECTOR A038 ACCESSORIES

2-pin

Pin	Wire	Description	Active Low ⁽¹⁾ Active High ⁽²⁾	Pin on ECN code
1	1175	Power supply (KL30)	-	E168: 2
2	M22	Ground (KL31)	-	-

(1) Active low: function is activated if pin is grounded.

(2) Active high: function is activated if pin is connected to battery plus (12 V minimum).

See section 11.12: "XF series microwave preparation" for more information about the location and function of this connector.

12.24 CONNECTOR A043 DRIVER SEAT CONNECTOR

Driver seat connector 2-pole

Pin	Wire	Description	Active Low ⁽¹⁾ Active High ⁽²⁾	Pin on ECU code
1	M802	Ground (KL31)	-	-
2	1240	Power supply (KL30)	-	D878: A18

(1) Active low: function is activated if pin is grounded.

(2) Active high: function is activated if pin is connected to battery plus (12 V minimum).

See section 7.13: "Connection points and permitted power loads" for the maximum load permitted on this connector.

BODYBUILDERS' GUIDELINES

Application connector (code) number list

12.25 CONNECTOR A058 TRAILER SYSTEM (ISO12098)

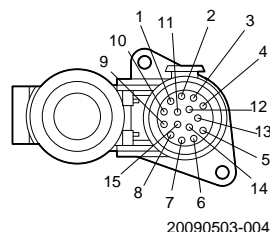

15 pin connector

Pin	Wire	Description	Active Low (1) Active High (2)	Pin on ECN code
1	2008	Direction indicator, left	AH	D358: A7
2	2009	Direction indicator, right	AH	D358: A8
3	2152	Rear fog lamp	AH	D878: A24
4	M131	Ground		
5	2102	Tail light and contour lighting, left, and number plate light	AH	D878: A33
6	2103	Tail light and contour lighting, right, and number plate light	AH	D878: A28
7	4601	Brake lights	AH	D878: C8
8	4591	Reversing lights	AH	D878: D23
9	1113	Power supply (KL30)		D878: C16
10	3659	Cargo door alarm system	AL	D911: B6
11	3660	Cargo internal alarm system	AL	D911: B4
12	3651	Power supply 12V alarm system		D911: A10
13	9088	Ground for 14 and 15		
14	3813	TT CAN high ISO 11992		D993: D12
15	3812	TT CAN low ISO 11992		D993: D13

(1) Active low: function is activated if pin is grounded.

(2) Active high: function is activated if pin is connected to battery plus (12 V minimum).

See section 10.15: "CF series trailer connection points" for the function of this connector on CF and XF vehicles.

12.26 CONNECTOR A068 (CHASSIS - ESC SYSTEM)

LF series with ESC system via the VIC unit

Selection code 9231: Chassis Connector A068				
Pin	Wire	Description	Active Low ⁽¹⁾ Active High ⁽²⁾	Pin on ECN code
1	M3 or M5	Ground (KL31)	-	-
2	3848	Remote Engine Stop (BBM only)	AH	(D993: C16)
3	3003	Engine speed output signal	AH	D364: B12
4	3039	Vmax special application	AL	D364: B20
5	3145 or	Set+ / ESC N2 ⁽³⁾	AH	D358L: D07
	3141	⁽⁴⁾	-	-
6	3146 or	Set- / ESC N3 ⁽³⁾	AH	D358L: D06
	3142	Ground ⁽⁴⁾	-	-
7	3143	ESC enable	AH	D358L: D09
8	3144	ESC N1 / N_variable	AH	D358L: D05
9	3145	ESC N2 / Set+	AH	D358L: D06
10	3146	ESC N3 / Set-	AH	D358L: D07
11	5280	Remote Engine Start (BBM only)	AH	(D993: D08)
12	2161	Power supply (KL30)	-	

(1) Active low: function is activated if pin is grounded.

(2) Active high: function is activated if pin is connected to battery plus (12 V minimum).

(3) In case chassis is specified with selco 8431 or 8665 (Manual or AS-Tronic gearbox)

(4) In case chassis is specified with selco 4207 (Allison Automatic gearbox). Note: there will be no wire fitted in the mating bulkhead connector 3P.

See section 9.3: "LF and CF65 series chassis connections" for more information about the location of this connector.

See section 9.10: "LF series ESC control" for more information about the ESC system available on LF vehicles.

BODYBUILDERS' GUIDELINES

Application connector (code) number list

A068 connection detail

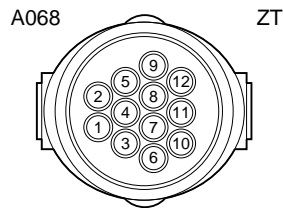

CF75 - 85 and XF series with ESC system via the BBM unit

Selection code 9231: Chassis Connector A068				
Pin	Wire	Description	Active Low ⁽¹⁾ Active High ⁽²⁾	Pin on ECN code
1	M37	Ground (KL31)	-	
2	3848	Engine Stop	AH	D993: C16
3	3003	Engine speed output signal	AL	D993: D05
4	3039	Vmax special application	AH	D993: C17
5	3141	Set + Esc	AH	D993: C19
6	3142	Set - Esc	AH	D993: C18
7	3143	ESC enable	AH	D993: C20
8	3144	N Variable	AH	D993: C21
9	3145	ESC N2	AH	D993: D06
10	3146	ESC N3	AH	D993: D07
11	5280	Engine start	AH	D993: D08
12	1240	Power supply (KL30)	-	

(1) Active low: function is activated if pin is grounded.

(2) Active high: function is activated if pin is connected to battery plus (12 V minimum).

See section 10.3: "CF75 and CF85 series chassis connections" for more information about the location of this connector.

See section 10.16: "CF75 - CF85 ESC system" for more information about the ESC system available on CF75-85 and XF vehicles.

12.27 CONNECTOR A070 ACCESSORIES 8-POLE)

A070 connector details

Pin	Wire	Description	Active Low ⁽¹⁾ Active High ⁽²⁾	Pin on ECN code
1	1113	Power supply (KL30)		D878: C17
2	2155	Body lighting	AH	D878: C01
3	4601	Brake signal	AH	D878: C08
4	4591	Reversing lights	AH	D878: D23
5	3651	power supply alarm system		D911: A10
6	3659	Cargo door alarm system (Note: not connected on LF vehicles)	AL	D911: B06
7	3660	Cargo internal alarm system (Note: not connected on LF vehicles)	AL	D911: B04
8	M21 /M71 (3)	Ground (KL31)		

(1) Active low: function is activated if pin is grounded.

(2) Active high: function is activated if pin is connected to battery plus (12 V minimum).

(3) Wire codes are: M21 or M71 for CF75 - 85 and XF series and M1 for LF and CF65 series.

- Section:9.3: "LF and CF65 series chassis connections" for LF and CF65 series.
- Section: 10.3: "CF75 and CF85 series chassis connections" for CF75 - 85 and XF series.

12.28 CONNECTOR A076 TELEPHONE

A076 Telephone preparation

Pin	Wire	Description	Active Low ⁽¹⁾ Active High ⁽²⁾	Pin on ECN code
1	1363	Power supply 12V (KL15)		D878: D01
2	1108	Power supply 12V (KL30)		D895: A04
3	M460	Ground (KL31)		

(1) Active low: function is activated if pin is grounded.

(2) Active high: function is activated if pin is connected to battery plus (12 V minimum).

See section 10.9: "CF series telephone preparation" for more information about the telephone preparation on CF and XF vehicles.

BODYBUILDERS' GUIDELINES

Application connector (code) number list

12.29 CONNECTOR A088 TAILLIFT SYSTEM 7-POLE

Pin	Wire	Description	Active Low ⁽¹⁾ Active High ⁽²⁾	Pin on ECN code
1	6167	Taillift standby for use signal	AH	D965: B04
2	6165	Taillift down	AL	G466: 87
3	6166	Taillift open		G466: 87a
4	1258	Power Supply (KL15)		E163: 2
5	6168	Taillift open	AH	G466: B01
6	6169	Taillift open	AL	G466: B02
7	6164	Power supply Taillift	AH	C889: 1

(1) Active low: function is activated if pin is grounded.

(2) Active high: function is activated if pin is connected to battery plus (12 V minimum).

See section 7.17: "Taillift preparation" for more information about the taillift system available on CF and XF vehicles.

See section 12.11: "Connector 12D body builder" for the (bulkhead) connector on the other end of the taillift wiringloom.

12.30 CONNECTOR A095 APPLICATION REFUSE COLLECTOR

21 Pole Refuse preparation connector - Bulkhead position 78B

Pin	Wire	Description	Pin on ECN code	Current	Active Low (1) Active High (2)	Related CP in BBM unit
1	3216	PTO ACTIVE Gives the status signal of PTO-1 from chassis	D993: D21 OUTPUT	0,5A	AH	1-94
2	3211	HIGH RPM REQUEST Request signal from the super-structure to activate high RPM	D993: D24 INPUT	5mA	AH	2-28 / 2-29 2-30 / 2-31
3	--	--	--	--	--	--
4	3039	FOOTBOARD PROTECTION / Vmax APPLICATION SPEED When this input is high, and gearbox is switched into reverse, engine stop and park brake becomes active. When this input is high, "Vmax application" will be active when Gearbox in Drive.	D993: C17 INPUT	5mA	AH or AL (3)	1-128 (3) 2-10
5	1113	KL30 15A, power supply 24V before contact for Work lights, fuse E048.	D878: C16	15A	n/a	n/a
6	1240	KL15 15A, power supply 24Volt, fuse E091. Other consumers are also connected via this power supply.	D878: A18	15A	n/a	n/a
7	4591	REVERSE GEAR INDICATOR Active when reverse gear is engaged (relay G350)	D878: D23	5A	n/a	n/a
8	M571	GROUND	SUPPLY	20A	n/a	n/a
9	1154	KL30 15A, power supply Hazard beacon lights. 24V, fuse E142.	SUPPLY	15A	n/a	n/a
10	4722	CAB UNLOCKED Active at open cab lock via relay G351. (except when cab fully tilted)	D878: D31	1,5A	n/a	n/a
11	1258	KL15 15A, supply voltage 24 V, fuse E163.	OUTPUT	15A	n/a	n/a
12	3238	ENGINE RUNNING Active when engine speed > 400 RPM. OUTPUT: 1,5A, <5V, 24V.	D993: A08 OUTPUT	1,5A	AH	n/a

BODYBUILDERS' GUIDELINES

Application connector (code) number list

Pin	Wire	Description	Pin on ECN code	Current	Active Low (1) Active High (2)	Related CP in BBM unit
13	3215	VEHICLE SPEED >5KM/H Active when vehicle speed > 5 km/h.	D993: D31 OUTPUT	0,5A	AH	n/a
14	3214	VEHICLE SPEED >10 KM/H Active when vehicle speed > 10 km/h.	D993: D32 OUTPUT	0,5A	AH	n/a
15	3212	ENGINE SPEED >1400 RPM Active when engine speed > 1400 RPM.	D993: D23 OUTPUT	0,5A	AH	n/a
16	M572	GROUND	OUTPUT	20A	AH	n/a
17	3213	BODY RELEASE Active if body active signal is high and all switch on conditions are met.	D993: D34 OUTPUT	1,0A	AH	1-99 / 1-100 1-101 / 1-102 1-103 / 1-104
18	3249	GEARBOX DRIVE EN- GAGED Active when gearbox is not in Neutral position	D993: D22 OUTPUT	0,5A	AH	n/a
19	3402	PARKING BRAKE SIGNAL Active when Parking brake is applied.	D358: B05 via R005: A5	1,5A	n/a	n/a
20	3248	AUXILIARY STOP (emergency) Stop signal from the superstructure.	D993: D36 INPUT	5mA	AH	n/a
21	3210	BODY ACTIVE Body active signal from superstructure. 24V input.	D993: C12 INPUT	5mA	AH	1-99

(1) AL = Active Low: function is activated if pin is grounded.

(2) AH = Active High: function is activated if pin is connection to battery plus (12V minimum).

(3) CP 1-128 = fault detection on pin C17 depending on footboard switch (switch to 24V or ground).

See section 10.19: "Refuse preparation CF75 - CF85 Series" for more information about the FMS system available on CF75-85 and XF vehicles.

12.31 CONNECTOR A097 FMS SYSTEM

Selection code 6407: FMS prepared (Cab Connector A097 (in location 34A of the bulkhead connector))				
Pin	Wire	Description	Active Low ⁽¹⁾ Active High ⁽²⁾	Pin on ECN code
1	9093	Ground (KL31)		
2				
3				
4	3773	Interconnection to A097:10		
5	3767	Interconnection to A098		A098: 5
6	3768	Interconnection to A098		A098: 6
7	3771	Interconnection to A098		A098: 7
8	3770	Interconnection to A098		A098: 8
9	3769	Interconnection to A098		A098: 15
10	3773	Interconnection to A097:4		
11	1101	Power supply (KL30)		E084 (10A)
12	9093	Ground (KL15)		
13				
14				
15				
16				
17	1101	Power supply (KL30)		D878: D14
18	1258	Power supply (KL15)		E163: C2
19				
20				
21				

(1) Active low: function is activated if pin is grounded.

(2) Active high: function is activated if pin is connected to battery plus (12 V minimum).

See section 10.17: "CF75 - 85 series FMS / DTS system" for more information about the FMS system available on CF75-85 and XF vehicles.

BODYBUILDERS' GUIDELINES

Application connector (code) number list

12.32 CONNECTOR A098 FMS SYSTEM

Selection code 6407: FMS prepared (Cab Connector A098 in location D878; central box dashboard)				
Pin	Wire	Description	Active Low ⁽¹⁾ Active High ⁽²⁾	Pin on ECN code
1	9093	Ground (KL31)		
2	3502	Vehicle speed		B525: B6
3	3237	Engine speed		D965: B1
4	3772	Interconnection to 12D		12D: 5
		interconnection to A104		A104: 1
5	3767	Interconnection to A097		A097: 5
6	3768	Interconnection to A097		A097: 6
7	3771	Interconnection to A097		A097: 7
8	3770	Interconnection to A097		A097: 8
9	3225	DTCO		B525: D8
10	3783 (3)	DCAN-H		D358: B12
11	3782 (3)	DCAN-L		D358: B06
12	4596	PTO	AH	D993: A4
13	4601	Stop Lights	AH	D878: C08
14	2102	Marker Lights	AH	D878: A33
15	3769	Interconnection to A097		A097: 9
16	-	-	-	-
17	1101	Power supply (KL30)		E084 (10A)
18	1258	Power supply (KL15)		E163 (25A)

(1) Active low: function is activated if pin is grounded.

(2) Active high: function is activated if pin is connected to battery plus (12 V minimum).

(3) See paragraph "terminator resistor D-CAN" in case of preparation.

See section 10.17: "CF75 - 85 series FMS / DTS system" for more information about the FMS system available on CF75-85 and XF vehicles.

12.33 CONNECTOR A100 HD-OBD DIAGNOSE

Heavy duty diagnose connector A100 (LF and CF65 series)				
Pin	Wire	Description	Active Low ⁽¹⁾ Active High ⁽²⁾	Pin on ECU
1	1357	Power supply (KL15)	-	D942: M3
2				
3	3425	K-line EBS	-	D403: A10/A11
4	9107	Ground (KL31)	-	
5	9107	Ground (KL31)	-	
6	3783	D-CAN High	-	D358L: B12
7			-	
8	3646	K-line	-	D905:10, D940:15, D929:9, D911:B15
9	4732	K-Line	-	D356L: C4, D851: 3,4
10			-	
11			-	
12	4733	K-line DIP4	-	D899: 03
13			-	
14	3782	D-CAN Low	-	D358L: B06
15	3037	K-line ACH-EW	-	D521: 4
16	1000	Power supply (KL30)	-	

(1) Active low: function is activated if pin is grounded.

(2) Active high: function is activated if pin is connected to battery plus (12 V minimum).

See section 9.1: "LF series cab switch and connector locations" for information about the location of the HD-OBD connector on LF vehicles.

See section 10.1: "CF series cab switch and connector locations" for information about the location of the HD-OBD connector on CF vehicles.

See section 11.1: "XF series cab switch and connector locations" for information about the location of the HD-OBD connector on XF vehicles.

BODYBUILDERS' GUIDELINES

Application connector (code) number list

Heavy duty diagnose connector A100 (CF and XF series)				
Pin	Wire	Description	Active Low ⁽¹⁾ Active High ⁽²⁾	Pin on ECU
1	1229	Power supply (KL15)	-	D878: A35
2	3797	K-line heater unit		B473: 11
3	3425	K-line EBS	-	D329: A10/A11
4	9107	Ground (KL31)	-	
5	9107	Ground (KL31)	-	
6	3783	D-CAN High	-	D358: B12
7			-	
8	3646	K-line CDS	-	D905: 10
9			-	
10	3065	K-line AS-Tronic	-	D954: A2
11	4883	K-line EST42	-	D902: 14
12	4733	K-line DIP4	-	D899: 03
13	3470	K-line AGS	-	B344: 03
14	3782	D-CAN Low	-	D358: B06
15	3037	K-line ACH-EW	-	D979: B03
16	1000	Power supply (KL30)	-	

(1) Active low: function is activated if pin is grounded.

(2) Active high: function is activated if pin is connected to battery plus (12 V minimum).

12.34 CONNECTOR A102 BODY BUILDER 8-POLE

8-pin Econoseal (for CF75-85 and XF series)

Pin	Wire	Description	Active Low ⁽¹⁾ Active High ⁽²⁾	Pin on ECN code
1	1154	Power supply (KL30)		E163: C2
2	1258	Power supply (KL15)		
3	3157	Engine running signal		D358: C42
4	3412	Cab locking open signal		F616: 02
5				
6				
7	M40	Ground (KL31)		
8	M98	Ground (KL31)		

(1) Active low: function is activated if pin is grounded.

(2) Active high: function is activated if pin is connected to battery plus (12 V minimum).

See section 10.3: "CF75 and CF85 series chassis connections" for more information about the location of this connector.

BODYBUILDERS' GUIDELINES

Application connector (code) number list

8-pin Econoseal (for LF and CF65 series)

Pin	Wire	Description	Active Low ⁽¹⁾ Active High ⁽²⁾	Pin on ECN code
1	1154	Power supply (KL30)		
2	2161	Power supply (KL15)		
3	3157	'Engine running' signal		D358L: C42
4	3412	Cab locking open signal		D911: B5
5				
6				
7	M2, M40	Ground (KL31)		
8	M1, M41, M43	Ground (KL31)		

(1) Active low: function is activated if pin is grounded.

(2) Active high: function is activated if pin is connected to battery plus (12 V minimum).

See section 9.3: "LF and CF65 series chassis connections" for more information about the location of this connector.

12.35 CONNECTOR A103 BODYBUILDER 12-POLE

12-pin connector spare wiring CF XF series

Pin	Wire	Description	Active Low ⁽¹⁾ Active High ⁽²⁾	Pin on ECN code
1	A1	Spare or		
	3772	Panic FMS		A098: 4
2	A2	Spare		12D:6
3	A3	Spare		12D:7
4	A4	Spare		12D:8
5	A5	Spare		12D:9
6	A6	Spare		12D:10
7	A7	Spare		12D:11
8	A8	Spare		12D:12
9	A9	Spare		12D:13
10	A10	Spare		12D:14
11	A11	Spare		12D:15
12				

(1) Active low: function is activated if pin is grounded.

(2) Active high: function is activated if pin is connected to battery plus (12 V minimum).

BODYBUILDERS' GUIDELINES

Application connector (code) number list

See section 9.3: "LF and CF65 series chassis connections" for more information about the location of this connector.

12.36 CONNECTOR A104 SPARE WIRING 18-POLE

18 pole connector spare wiring radio compartment

Pin	Wire	Description	Active Low ⁽¹⁾ Active High ⁽²⁾	Pin on ECN code
1	A1	Spare or		A103:1
	3772	Panic button FMS (connector A098)		
2	A2	Spare		A103:2
3	A3	Spare		A103:3
4	A4	Spare		A103:4
5	A5	Spare		A103:5
6	A6	Spare		A103:6
7	A7	Spare		A103:7
8	A8	Spare		A103:8
9	A9	Spare		A103:9
10	A10	Spare		A103:10
11	A11	Spare		A103:11
12	-	-		
13	-	-		
14	-	-		
15	-	-		
16	-	-		
17	-	-		
18	-	-		

(1) Active low: function is activated if pin is grounded.

(2) Active high: function is activated if pin is connected to battery plus (12 V minimum).

See section 10.5: "CF series accessories connection in dashboard" for more information about the spare wiring that is available behind the radio console of CF75-85 and XF vehicles.

12.37 CONNECTOR A105 BODYBUILDER CAN SYSTEM 7-POLE

Selection code 9562: Chassis Connector A105				
Pin	Wire	Description	Active low ⁽¹⁾ Active high ⁽²⁾	Pin on ECN code
1	1154	Power supply (KL30)	-	-
2	M982	Ground (KL31)	-	-
3	3809	Enable CAN open	AL	R003: A3
4	3811	BB_CAN_High	-	D993: D17
5	3842	BB_CAN_ground	-	D993: D09
6	3810	BB_CAN_Low	-	D993: D19
7	-	-	-	-

(1) Active low: function is activated if pin is grounded.

(2) Active high: function is activated if pin is connected to battery plus (12 V minimum).

See section 10.16: "CF75 - CF85 ESC system" for more information about the ESC system available on CF75-85 and XF vehicles.

See section 10.18: "CF series PTO control / protection" for more information about the PTO control system available on CF vehicles.

12.38 CONNECTOR A106 CAN-CAB 9-POLE

Selection code 9562: Chassis Connector A106				
Pin	Wire	Description	Active Low ⁽¹⁾ Active High ⁽²⁾	Pin on ECN code
1	1154	Power supply (KL30)	-	E142: B02
2	M372	Ground (KL31)	-	-
3	3809	Enable CAN open	AL	R003: A03
4	3811	BB_CAN_High	-	D993: D17
5	3842	BB_CAN_ground	-	D993: D09
6	3810	BB_CAN_Low	-	D993: D19
7	-	-	-	-

(1) Active low: function is activated if pin is grounded.

(2) Active high: function is activated if pin is connected to battery plus (12 V minimum).

See section 10.16: "CF75 - CF85 ESC system" for more information about the ESC system available on CF75-85 and XF vehicles.

BODYBUILDERS' GUIDELINES

Application connector (code) number list

See section 10.18: "CF series PTO control / protection" for more information about the PTO control system available on CF vehicles.

12.39 CONNECTOR A113 GARBAGE TRUCK

12 Pole lighting connector - Bulkhead position 8A

Connector A113 in location 8A Bulkhead lead through				
Pin	Wire	Description	Active Low ⁽¹⁾ Active High ⁽²⁾	Pin on ECU code
1	M573	Ground (KL31)		
2	M574	Ground (KL31)		
3	4601	Brake lights	Ah	D878: C08
4	2102	Marker light left	Ah	D878: A33
5	2103	Marker light right	Ah	D878: A28
6	2008	Direction indicator left	Ah	D358: A07
7	2009	Direction indicator right	Ah	D358: A08
8	-	-		
9	-	-		
10	2152	Rear fog light	Ah	D878: A24
11	-	-		
12	-	-		

(1) Active low: function is activated if pin is grounded.

(2) Active high: function is activated if pin is connected to battery plus (12 V minimum).

See section 10.2: "CF series bulkhead connection overview" for more information about the location of this connector.

See section 10.19: "Refuse preparation CF75 - CF85 Series" for more information about the ESC system available on CF75-85 and XF vehicles.

12.40 CONNECTOR A117 TRAILER 13-POLE

Trailer connector A117

Pin	Wire	Description	Active Low ⁽¹⁾ Active High ⁽²⁾	Pin on ECN code
A	1113	Power before contact (KL30)		
G	2152	Fog light		D878: D24
56	4591	Reverse light		D878: D23
58L	2102	Marker lights_LH		D878: A33
58R	2103	Marker lights_RH		D878: A28
54	4601	Stoplights		D878: C08
54L	2008	Direction indicator_L		D358: A08
54R	2009	Direction indicator_R		D358: A07
31	M135	Ground (KL31)		

(1) Active low: function is activated if pin is grounded.

(2) Active high: function is activated if pin is connected to battery plus (12 V minimum).

See section 7.13: "Connection points and permitted power loads" for the maximum load permitted on this connector.

BODYBUILDERS' GUIDELINES

Application connector (code) number list

12.41 CONNECTOR A122 HYDRAULIC PLATFORM 9- POLE

Hydraulic Platform connector - Bulkhead position 8A

Pin	Wire	Description	BBM Pin INPUT / OUTPUT	Active Low (1) Active High (2)	Related CP in BBM unit
1	3883	BODY NOT SECURED	D01 OUTPUT	AH	
2	3893	CLOSET OPEN direct relation to body secured	NA		
3					
4	3879	VEHICLE SPEED 1 Vehicle Speed>parameter value vehicle speed 1 level, then Vehicle Speed 1 output must be active. At set speed – 3 km/h of parameter value the output must be deactivated	D31 OUTPUT	AH	1-129
5	3880	VEHICLE SPEED 2 Vehicle Speed>parameter value vehicle speed 2 level, then Vehicle Speed 2 output must be active. At set speed – 3 km/h of parameter value the output must be deactivated	D32 OUTPUT	AH	1-130
6	3881	VEHICLE SPEED 3 Vehicle Speed>parameter value vehicle speed 3 level, then Vehicle Speed 3 output must be active. At set speed – 3 km/h of parameter value the output must be deactivated	D23 OUTPUT	AH	1-131
7	3882	VEHICLE SPEED 4 Vehicle Speed>parameter value vehicle speed 4 level, then Vehicle Speed 4 output must be active. At set speed – 3 km/h of parameter value the output must be deactivated	D34 OUTPUT	AH	1-132
8		-	-		
9		-	-		

(1) Active Low: function is activated if pin is grounded

(2) Active High: function is activated if pin is connected to Ubat (12V minimum)

See section 10.20: "Hydraulic Platform CF75 series" for information about the function of this connector on CF75 vehicles.

See section 10.2: "CF series bulkhead connection overview" for information about the location of this connector on CF vehicles.

12.42 CONNECTOR A123 HYDRAULIC PLATFORM 21- POLE

Hydraulic Platform preparation - Bulkhead position 78B

Pin	Wire	Description	BBM Pin INPUT / OUTPUT	Active Low (1) Active High (2)	Related CP in BBM unit
1	M1	GROUND SUPPLY	SUPPLY	n/a	n/a
2	3884	ENGINE RUNNING Active when engine speed > 400 RPM. OUTPUT: 1,5A, <5V, 24V.	A08 OUTPUT	AH	2-28 / 2-29 2-30 / 2-31
3	5463	SURROUND LIGHT Active if body release is active and all switch on conditions are met.	A03 OUTPUT	AH	n/a
4	3886	BODY RELEASED Active if body active signal is high and all switch on conditions are met.	D21 OUTPUT	AH	1-128 2-10
5	3887	VARIABLE ENGINE SPEED (VES) Range from 0,5 – ≤ 2,5 Volt = VES is inac- tive Range from > 2,5 – 5 Volt = VES is standby Range from ≥ 5 – 15 Volt = VES is active be- tween idle (1000 RPM) and 3000 RPM	D29 INPUT	n/a	n/a
6	3888	WALL CONNECTION when active starting the engine is inhibited.	D36 INPUT	AH	n/a
7	3889	SAFETY FEEDBACK when active in combination with body release function engine will stall.	D26 INPUT	AL	n/a
8	3890	HIGH RPM REQUEST Request signal from the superstructure to ac- tivate high RPM	D24 INPUT	n/a	n/a
9	3891	BODY SECURED Body secured signal from superstructure. 24V input.	D35 INPUT	n/a	n/a
10	3893	CLOSET OPEN Active at open closet via relay G351.	n/a	AH	n/a
11	3892	REMOTE START STOP The function will generate depending on the pulse (rising edge) of the switch an internal start or an internal stop signal depending on the engine speed condition.	C12 INPUT	AH	n/a
12	1258	KL15 15A, supply voltage 24 V, fuse E163.	SUPPLY	n/a	n/a
13	--	--	--	--	--
14	--	--	--	--	--
15	--	--	--	--	--
16	--	--	--	--	--
17	--	--	--	--	--
18	--	--	--	--	--

BODYBUILDERS' GUIDELINES

Application connector (code) number list

Pin	Wire	Description	BBM Pin INPUT / OUTPUT	Active Low ⁽¹⁾ Active High ⁽²⁾	Related CP in BBM unit
19	--	--	--	--	--
20	--	--	--	--	--
21	--	--	--	--	--

(1) Active Low: function is activated if pin is grounded.

(2) Active High: function is activated if pin is connection to battery plus (12V minimum).

See section 10.17: "CF75 - 85 series FMS / DTS system" for more information about the FMS system available on CF75-85 and XF vehicles.

12.43 CONNECTOR A125 HYDRAULIC PLATFORM FEED THROUGH

Pin	Wire	Description	Active Low ⁽¹⁾ Active High ⁽²⁾	Pin on ECN code
1	-	-	-	-
2	-	-	-	-
3	-	-	-	-
4	-	-	-	-
5	-	-	-	-
6	-	-	-	-
7	1258	Power supply (KL15)	-	-
8	-	-	-	-
9	1258	Power supply (KL15)	-	-
10	-	-	-	-
11	-	-	-	-
12	1258	Power supply (KL15)	-	-
13	-	-	-	-
14	-	-	-	-
15	-	-	-	-
16	-	-	-	-
17	-	-	-	-
18	-	-	-	-
19	-	-	-	-
20	-	-	-	-
21	-	-	-	-

(1) Active low: function is activated if pin is grounded.

(2) Active high: function is activated if pin is connected to battery plus (12 V minimum).

See section 10.20: "Hydraulic Platform CF75 series" for information about the function of this connector on CF75 vehicles.

12.44 CONNECTOR A126 FMS 2-POLE

Selection code 6407: FMS prepared				
Pin	Wire	Description	Active Low ⁽¹⁾ Active High ⁽²⁾	Pin on ECN code
1	3783	D-CAN High		D358L: B12
2	3782	D-CAN Low		D358L: B06

(1) Active low: function is activated if pin is grounded.

(2) Active high: function is activated if pin is connected to battery plus (12 V minimum).

See section 9.12: "LF series FMS system" for more information on the FMS system on LF vehicles.

For After Sales part number information; see section 13.5: "Electric connector parts cabine (LF Series)".

BODYBUILDERS' GUIDELINES

Application connector (code) number list

12.45 CONNECTOR A134 REFUSE FEED THROUGH WIRE

Pin	Wire	Description	Active Low ⁽¹⁾ Active High ⁽²⁾	Pin on ECN code
1	-	-		
2	-	-		
3	-	-		
4	3039	Ground (KL31)		
5	-	-		
6	-	-		
7	-	-		
8	3039	Ground (KL31)		
9	-	-		
10	-	-		
11	-	-		
12	-	-		
13	-	-		
14	-	-		
15	-	-		
16	-	-		
17	-	-		
18	-	-		
19	-	-		
20	-	-		
21	-	-		

(1) Active low: function is activated if pin is grounded.

(2) Active high: function is activated if pin is connected to battery plus (12 V minimum).

See section 10.19: "Refuse preparation CF75 - CF85 Series" for more information about the Refuse preparation on CF75 - 85 vehicles.

12.46 CONNECTOR A138 FMS 12-POLE

Selection code 6407: FMS prepared (Cab Connector A138)				
Pin	Wire	Description	Active Low ⁽¹⁾ Active High ⁽²⁾	Pin on ECU
1	9093	Ground (KL31)	-	-
2	-	-	-	-
3	1363	Power supply (KL15 12V)	-	D878: D1
4	9162	Ground (KL31)	-	-
5	-	-	-	-
6	3783 A ⁽³⁾	D-CAN H	-	D358: B12
7	-	-	-	-
8	-	-	-	-
9	3782 A ⁽³⁾	D-CAN L	-	D358: B06
10	1258	Power supply (KL15)	-	E163 (25A)
11	1130	Accessoires	-	D878: D11
12	1101	Power supply (KL30)	-	D878: D14

(1) Active low: function is activated if pin is grounded.

(2) Active high: function is activated if pin is connected to battery plus (12 V minimum).

(3) See paragraph "terminator resistor D-CAN" in section 10.17: "CF75 - 85 series FMS / DTS system" in case of preparation.

See section 10.17: "CF75 - 85 series FMS / DTS system" for more information about the FMS system available on CF75-85 and XF vehicles.

12.47 CONNECTOR A139 - A140 EXTRA CAMERA

Connector A139

Pin	Wire	Description	Active Low ⁽¹⁾ Active High ⁽²⁾	Pin on ECN code
1	5469	Surveillance trigger	AI	D333:04

(1) Active low: function is activated if pin is grounded.

(2) Active high: function is activated if pin is connected to battery plus (12 V minimum).

Connector A140

Pin	Wire	Description	Active Low ⁽¹⁾ Active High ⁽²⁾	Pin on ECN code
1	1101	Power supply (KL30)	-	-

(1) Active low: function is activated if pin is grounded.

(2) Active high: function is activated if pin is connected to battery plus (12 V minimum).

BODYBUILDERS' GUIDELINES

Application connector (code) number list

See section 7.13: "Connection points and permitted power loads" for the maximum load permitted on this connector.

12.48 CONNECTOR D318 (ECU) TOLL COLLECT

Selection code 9681: Toll Collect prepared				
Pin	Wire	Description	Active Low ⁽¹⁾ Active High ⁽²⁾	Pin on ECU
A1	1101	Power supply (KL 30)		D878: E084
A2	2630	Search light		D878: E117
A3	1258	Power supply (KL15)		E163
A5	9025	Ground (KL31)		
B3	3502	Vehicle speed		B525: B6
C1	3831	VCC5	-	D319: 01
C2	3832	Ground (KL31)	-	D319: 02
C3	3833	VCC	-	D319: 03
C5	3837	CAN H	-	D319: 05
C6	3835	Wake up acknowledge	-	D319: 06
C7	3836	CAN L	-	D319: 07
C8	3834	Wake_up	-	D319: 04
F1		GPS antenna coax	-	D345: B1
F2		GPS antenna coax GND	-	D345: B2
E1		GPS antenna coax	-	D345: A1
E2		GPS antenna coax GND	-	D345: A2

(1) Active low: function is activated if pin is grounded.

(2) Active high: function is activated if pin is connected to battery plus (12 V minimum).

See section 10.1: "CF series cab switch and connector locations" for more information about the Toll Collect ECU location on CF75-85 vehicles.

See section 11.1: "XF series cab switch and connector locations" for more information about the Toll Collect ECU location on XF vehicles.

12.49 CONNECTOR D365.A - D365.B RADIO SYSTEM

D365.A power supply

Pin	Wire	Description	Active Low ⁽¹⁾ Active High ⁽²⁾	Pin on ECN code
1				
2				
3				
4	1130	Power supply (KL30)		D942: BA2
5				
6	1106	Power supply (KL30)		D942: DB9
7	M465	Ground (KL31)		

(1) Active low: function is activated if pin is grounded.

(2) Active high: function is activated if pin is connected to battery plus (12 V minimum).

D365.B speakers connection

Pin	Wire	Description	Active Low ⁽¹⁾ Active High ⁽²⁾	Pin on ECN code
1	4831	Right rear min		
2	4832	Right rear plus		
3	5448	Right front plus		
4	5449	Right front min		
5	5450	Left front plus		
6	5451	Left front min		
7	4827	Left rear min		
8	4828	Left rear plus		

(1) Active low: function is activated if pin is grounded.

(2) Active high: function is activated if pin is connected to battery plus (12 V minimum).

See section 9.7: "LF series radio preparation" for more information about the location of this connector.

BODYBUILDERS' GUIDELINES

Application connector (code) number list

12.50 CONNECTOR D347.A - D347.B RADIO SYSTEM

D347.A power supply

Pin	Wire	Description	Active Low ⁽¹⁾ Active High ⁽²⁾	Pin on ECN code
1				
2				
3				
4	1130	Power supply (KL30)		D878: D11
5				
6	1106	Power supply (KL30)		D878: D15
7	M465	Ground (KL31)		

(1) Active low: function is activated if pin is grounded.

(2) Active high: function is activated if pin is connected to battery plus (12 V minimum).

D347.B speakers connection

Pin	Wire	Description	Active Low ⁽¹⁾ Active High ⁽²⁾	Pin on ECN code
1	4831	Right rear min		
2	4832	Right rear plus		
3	5448	Right front plus		
4	5449	Right front min		
5	5450	Left front plus		
6	5451	Left front min		
7	4827	Left rear min		
8	4828	Left rear plus		

(1) Active low: function is activated if pin is grounded.

(2) Active high: function is activated if pin is connected to battery plus (12 V minimum).

See section 11.6: "XF series radio preparation"
for more information about the location of this
connector.

12.51 ECN CODE NUMBER OVERVIEW

ECN code	Description	ECN code	Description	ECN code	Description
B245	Valve PTO-1 control	D318	ECU Toll Collect		
B246	Valve PTO-2 control	D319	Radar Toll Collect		
B330	Buzzer door open/park brake not applied	D324	ECU telematics	E...	Fuses (see overview in cab)
B344	ECU AGS	D330	ECU 24/12V 10A		

BODYBUILDERS' GUIDELINES

Application connector (code) number list

ECN code	Description	ECN code	Description	ECN code	Description
B405	Valve PTO-3 control	D345	Aerial Toll Collect		
B473	Heater unit	D356	ECU 24/12V	F117	Switch PTO status 3rd
B525	Tachograaf			F616	Sensor Cab lock
C201	Light rear left	D358	ECU VIC3		
C202	Light rear right	D358L	ECU VIC3L	G005	Relay rear fog lights
C244	Light interior driver side	D364	ECU ECS-IBSe	G036	Relay brake light
C245	Light interior co-driver side	D403	ECU ABS-E2	G201	Relay fuel heater
C748	Switch cross lock	D521	ECU ACH-W2	G350	Relay reverse light
C880	Switch reversing buzzer	D878	Central Box	G353	Relay contact
C889	Switch Taillift	D895	ECU 24V/12V 10A	G460	Time relay (60s)
C927	Switch light auxiliary driving roof	D899	ECU DIP4	G462	Relay work light
C960	Switch roof hatch screen	D902	ECU Intarder EST42	G763	Power distribution
		D905	ECU CDS		
		D911	ECU Alarm ALS-S	L036	Loud speaker dual coil
		D929	Central Box		
		D942	Fusebox	R003	Relay CAN-open enable
		D954	Modulator AS Tronic		
		D965	ECU DMCI		
		D977	ECU EBS-2		
		D979	ECU ACH-EW		
		D993	ECU body builder module		

BODYBUILDERS' GUIDELINES

Application connector (code) number list

PART NUMBERS

	Page	Date
13.1 Mountings	405	201019
13.2 Flange bolts	408	201019
13.3 Electric connector parts	408	201019
13.4 Electric connector parts cabine (CF75-85 and XF Series)	410	201019
13.5 Electric connector parts cabine (LF Series)	411	201019
13.6 Electric cable contour lights chassis	413	201019
13.7 Extension piece for the LF mud guard	413	201019
13.8 Indication lamps	414	201019
13.9 Switches	415	201019
13.10 CVSG Gauges	415	201019
13.11 Adapters air system	417	201019
13.12 Lowered drawbar components	419	201019
13.13 Miscellaneous parts	421	201019

BODYBUILDERS' GUIDELINES

Part numbers

13.PART NUMBERS

13.1 MOUNTINGS

Part numbers

Tie rod		
Item	Part number	Quantity
A	1240928	1
B	1321533	1
C	1202089	1
D	0523917	1

Attachment plate		
Item	Part number	Quantity
A	0290591 ⁽¹⁾ (CF75-85 and XF Series)	1
B	1231056 (M12 x 40 mm)	3
C	1231051 (M12)	3
D	1403666 (LF and CF65 Series)	1
E	1231055 (M12 x 35 mm)	3

(1) Items A, B and C also available in set with DAF partnumber: 0370729.

Attachment plate		
Item	Part number	Quantity
A	0654833	1
B	1231064	3
C	1669590	3

BODYBUILDERS' GUIDELINES

Part numbers

Mounting bracket ⁽²⁾					
Set ⁽¹⁾	A	B	C	D	E
-	MAK8208	14	5	13	55
-	1212965	13	7	17	60
0591092	0290590	-	7	17	-
-	1403668	13	5	13	50

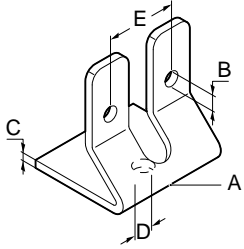

20070604-009

(1) Set = bracket with flange bolts and nuts.

(2) For more information also see sub section "Tie rods" in: 3.2: "BAM's - body attachment methods"

Mounting console (for tanker)		
Item	Part number	Quantity
A	n/a	1
B	1231066	3
C	0282263	3
D	1243045	2
E	0274020	2
F	1321533	2

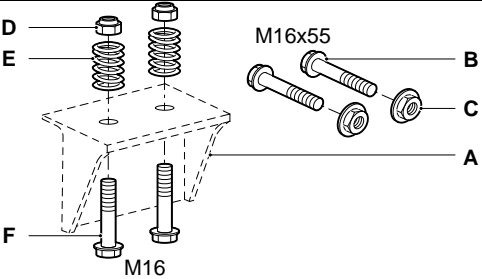

G000301

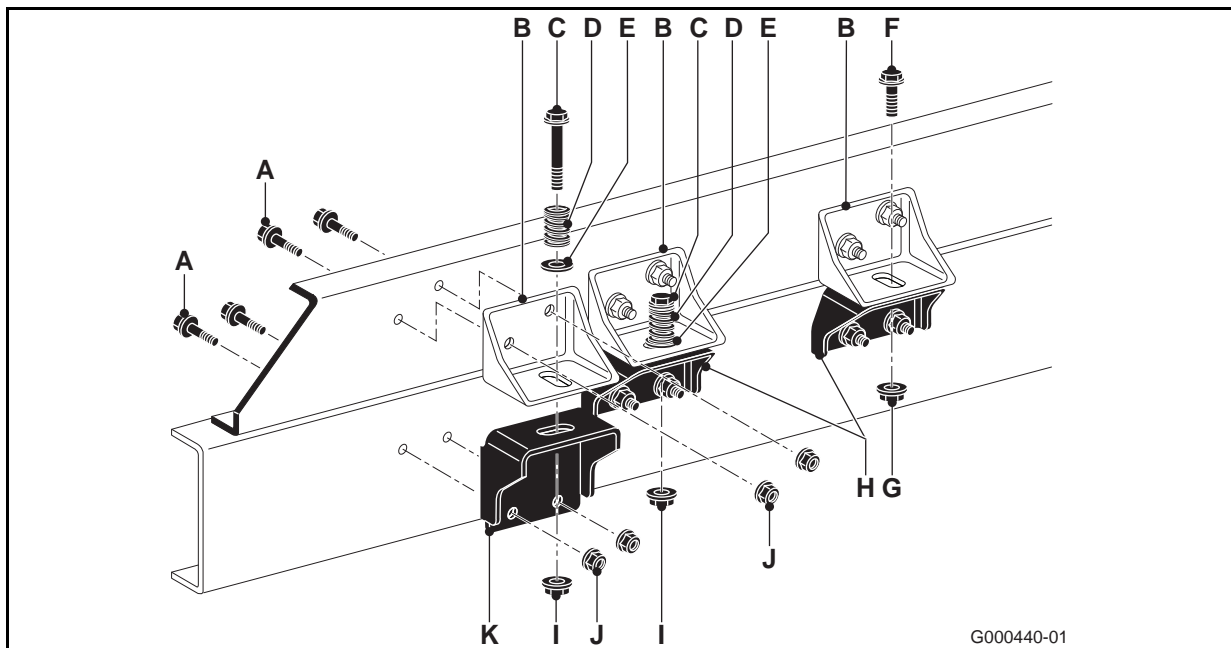

Item	Description	Quantity	Part number	Notes
A	Flanged bolt	x	1231054 1231055	M12-10.9 x 30 mm (single chassis frame) M12-10.9 x 35 mm (double chassis frame)
B	Console	2	1409881	Upper console for sub-frame
C	Flanged bolt	x	1243046	M16-10.9 x 110 mm
D	Spring	x	0274020	

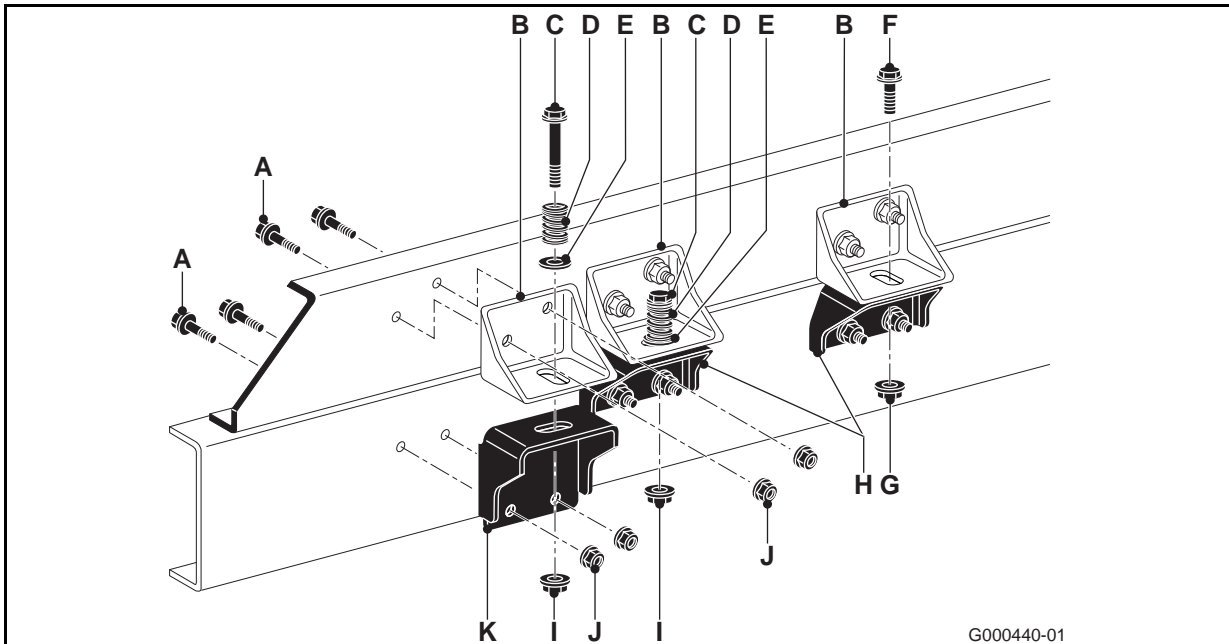

G000440-01

Item	Description	Quantity	Part number	Notes
E	Washer	x	0640205	∅ 35 x 17 x 4 mm (295 - 350 HV)
F	Flanged bolt	x	1243050	M16-10.9 x 35 mm
G	Flanged nut	x	1669590	M16-10.9
H	Console	x	1409358	Console
I	Flanged nut	x	1321533	Prevailing torque M16 flanged nut
J	Flanged nut	x	1231051	M12-10.9
K	Console	x	1409372	Console

Chassis cross connecting member			
Item ⁽¹⁾	Part number	L [mm]	
A	1662797	766	
	1439638	776	

G000398

(1) Cross member assy to be installed with M16 flange bolts

Cab suspension springs in combination with top sleeper mounting, CF series

Cab type	Quantity	Part number	Cab suspension
Day cab	2	1265278	Front
	2	1451155	Rear
Sleeper Cab	2	1265278	Front
	2	1265272	Rear

BODYBUILDERS' GUIDELINES

Part numbers

13.2 FLANGE BOLTS

<p>The property class of the flange bolts ⁽¹⁾used in the chassis of the CF and XF Series is 10.9. The part numbers for the different length versions of these flange bolts are given in the table below.</p>							
a: Flange bolt property class 10.9	l = 30	l = 35	l = 40	l = 45	l = 50	l = 55	b: Flange nut property class 10
M12x1.75 (c: 5,25 mm)	1231054	1231055	1231056	1231057	1231058	1231059	1231051
M14x2 (c: 6,00 mm)	1243041	1243061	1243060	1243059	1243058	1243057	1243043
M16x2 (c: 6,00 mm)	-	1243050	1231063	1231064	1231065	1231066	1231052

(1) For the flange bolt tightening torques, see section 2.6: "Attachment of components to the chassis".

13.3 ELECTRIC CONNECTOR PARTS

Item	Description	Quantity	Part number	Notes
A	Sealing ring	x	1305193	Blind sealing plug
B	Connector	1	1261638	4-pin connector housing
		1	1261636	8-pin connector housing
		1	1278100	12-pin connector housing
D	Contact pin	x	1261640	0.5 - 1.0 mm ²
		x	1267698	1.5 - 2.5 mm ²
F	Sealing plug	x	1258968	0.5 - 1.0 mm ²
		x	1258969	1.5 - 2.5 mm ²
G	Sealing plug	x	1258970	Blind sealing plug

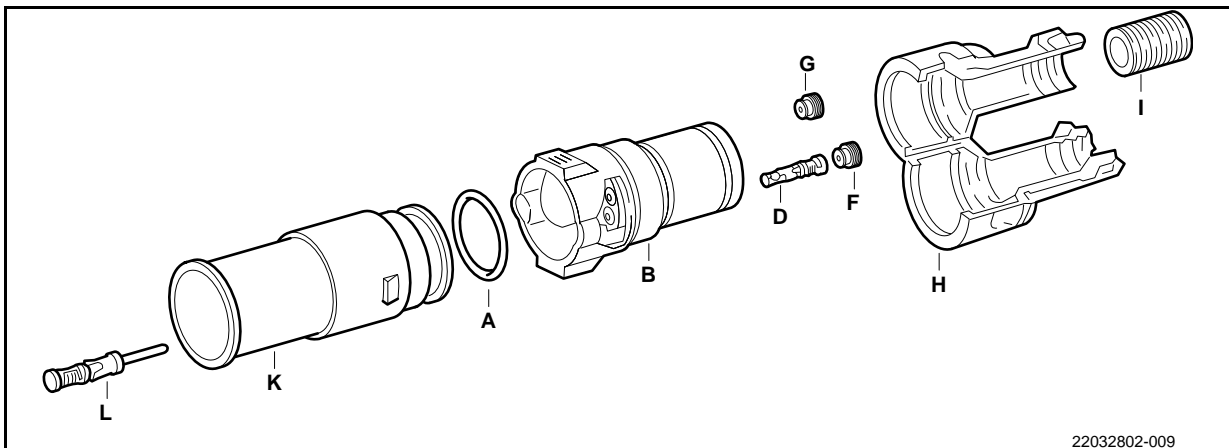

22032802-009

Item	Description	Quantity	Part number	Notes
H	Connector	1	1226724	For 4-pin connector and 10 mm hose (pos. I)
		1	1278520	For 8-pin connector and 13 mm hose (pos. I)
		1	1278099	For 12-pin connector and 17 mm hose (pos. I)
I	Protective hose	x	0090863	∅ 13 mm
		x	0090862	∅ 10 mm
		x	0090865	∅ 17 mm
K	Connector	1	1261637	For 4-pin connector
		1	1261635	For 8-pin connector
		1	1278101	For 12-pin connector
L	Contact pin	x	1261641	0.5 - 1.0 mm ²
		x	1267697	1.5 - 2.5 mm ²

BODYBUILDERS' GUIDELINES

Part numbers

Electrical contact kit supplied with the LF chassis

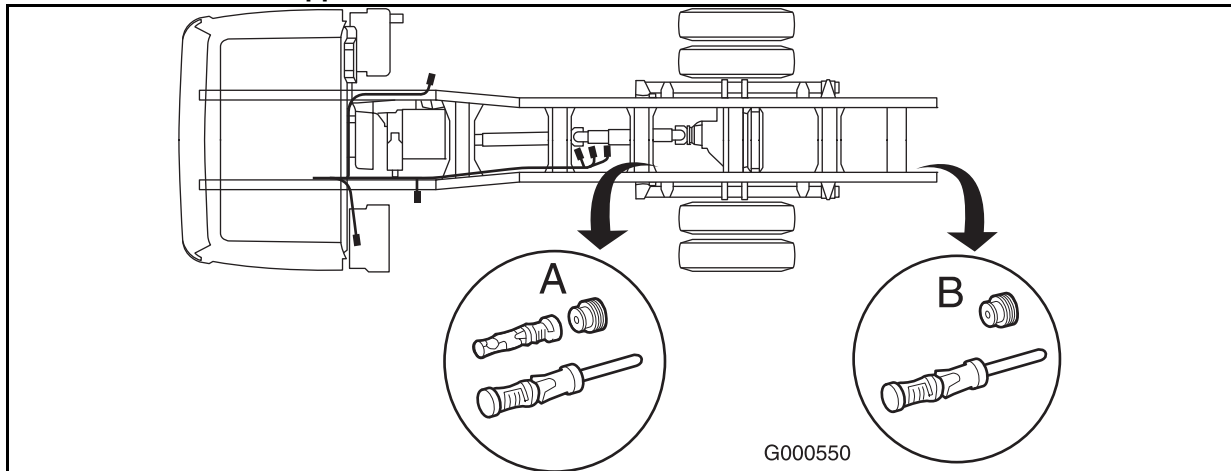

Kit	Description	Quantity	Part number	Notes
A (1)	Contact pin (female)	14	1261641	0.5 - 1.0 mm ²
		1	1267697	1.5 - 2.5 mm ²
	Contact pin (male)	5	1261640	0.5 - 1.0 mm ²
		3	1267698	1.5 - 2.5 mm ²
	Sealing plug	19	1258968	0.5 - 1.0 mm ² (color: blue)
4		1258969	1.5 - 2.5 mm ² (color: white)	
B (2)	Contact pin (male)	7	1261640	0.5 - 1.0 mm ²
		1	1267698	1.5 - 2.5 mm ²
	Sealing plug	7	1258968	0.5 - 1.0 mm ² (color: blue)
		1	1258969	1.5 - 2.5 mm ² (color: white)

(1) kit A = plastic bag strapped against standard chassis wiringloom if chassis is ordered with the ESC system (= selection code 9231).

(2) kit B = plastic bag strapped against standard chassis wiringloom (always supplied).

13.4 ELECTRIC CONNECTOR PARTS CABINE (CF75-85 AND XF SERIES)

Cab / bulkhead connectors (CF75-85 and XF Series)

Cab connectors (male and female type); for pins see following table

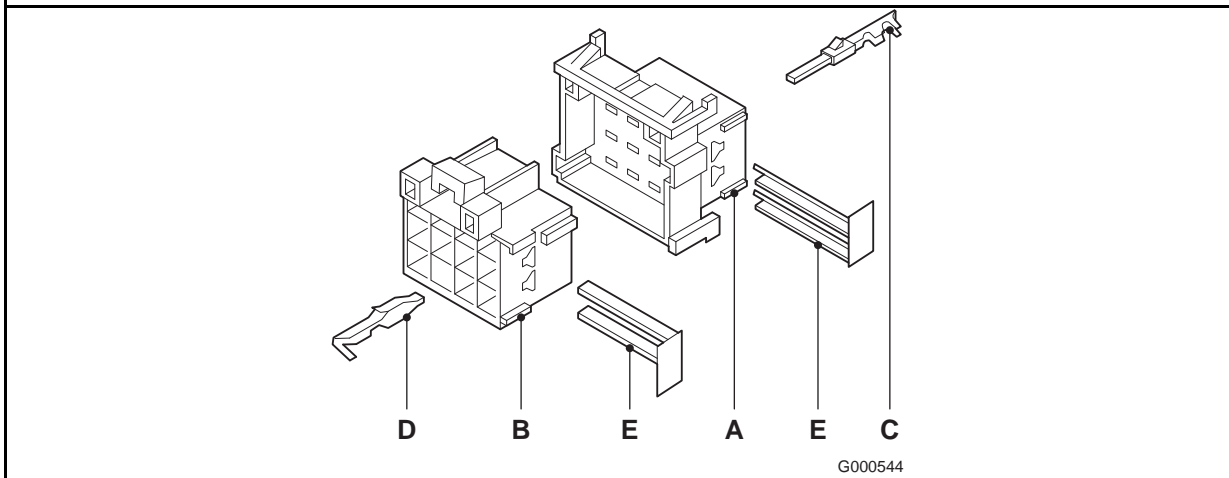

connector (female type) A ⁽¹⁾					connector (male type) B ⁽¹⁾				
Qty of Pins	DAF number and color				DAF number and color				
	Grey	Blue	Yellow	Green	Grey	Blue	Yellow	Green	Purple
6	1313845	1313846	1313847	1354021	1306709	1315071	1315072	1364069	-
9	1312604	1312611	1313806	1365784	1306710	1313809	1313838	1364299	-
12	1312605	1312610	1313804	1354022	1306711	1313808	1313812	1364070	1743590
18	1312607	1312609	1313803	1354023	1306713	1313807	1313811	1364071	-
21	1312606	1312612	1313805	1354024	1306714	1313810	1313839	1364072	-

- (1) locking device E for connector with :
- 6 pins: 1317004
 - 9 pins: 1317005
 - 12 pins: 1317006
 - 18 pins: 1317008
 - 21 pins: 1317009

Pins to be used in:

connector C:	
JPT male contact for 0.5 - 1.0 mm wire diameter	1315076
JPT male contact for 0.5 - 1.0 mm wire diameter or 2x 1.0 mm diameter	1325801
Connector D:	
JPT female contact for 0.5 - 1.0 mm wire diameter	1315077
JPT female contact for 0.5 - 1.0 mm wire diameter or 2x 1.0 mm diameter	1315078

**13.5 ELECTRIC CONNECTOR PARTS
CABINE (LF SERIES)**

Cab / bulkhead connectors (LF Series)

BODYBUILDERS' GUIDELINES

Part numbers

Cab connectors (male and female type); for pins see following table

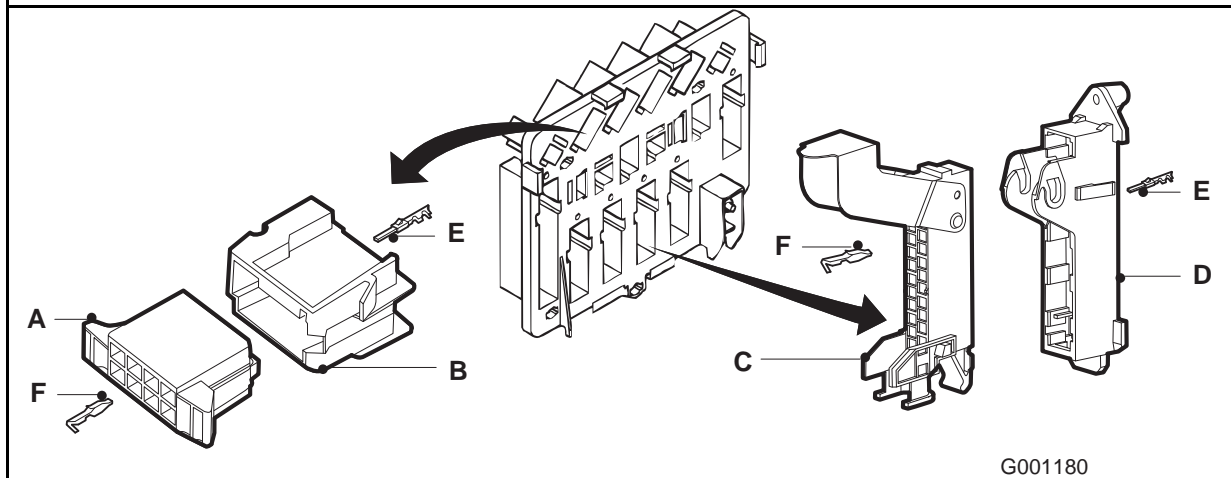

Qty of Pins	connector	DAF number and color							
		Blue	Yellow	White	Green	Red	Brown	Grey	Purple
8	A	-	1606389	1404127	-	1406116	1606390	1605771	1605770
	B	-	1606396	1404129	-	1606397	1606434	1605768	1405404
16	C	1607492	-	1605085	1606435	1607143	1607144	-	-
	D	1607586	-	1454349	1454347	1607584	1607588	-	-
25	C	-	1606320	-	-	-	-	-	-
	D	-	1454356	-	-	-	-	-	-

Pins used are:

contact E:	
JPT male contact for 0.4 - 1.0 mm wire diameter	1405371
JPT male contact for 1.0 - 3.0 mm wire diameter	1404126
Contact F:	
JPT female contact for 0.4 - 1.0 mm wire diameter	1401092
JPT female contact for 1.0 - 3.0 mm wire diameter	1404128

FMS connector A126 FMS 2-pole (LF series; positioned in dashboard recess)

DAF Part number	Qty	Description
1804571	1x	Connector housing
1804573	1x	Electrical contact
1804575	1x	Wedge

FMS connector A126 FMS 2-pole counter part (LF series; third party telematic system)

DAF Part number	Qty	Description
1804572	1x	Connector housing
1804574	1x	Electrical contact
1804576	1x	Wedge

13.6 ELECTRIC CABLE CONTOUR LIGHTS CHASSIS

LF, CF and XF chassis

Electric cable		
Item	Part number	Total quantity of LED lights
A (1)	1697589	4x
	1697590 (illustrated)	6x
	1697591	8x
B	1731959	1x (color: amber)

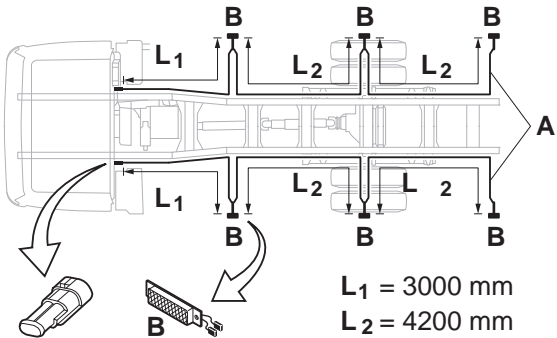

$L_1 = 3000 \text{ mm}$
 $L_2 = 4200 \text{ mm}$

G000538

(1) Part number = kit with 2 separate (identical) electric cables.

13.7 EXTENSION PIECE FOR THE LF MUD GUARD

Extension piece for the LF cab mud guard to enable repositioning of the indicator lights.

Extension piece ⁽¹⁾		
Item	Part number	Quantity
A	1453911 (RH)	1
	1453912 (LH)	1
B	1453909 (RH)	1
	1453910 (LH)	1
C	1453913	2

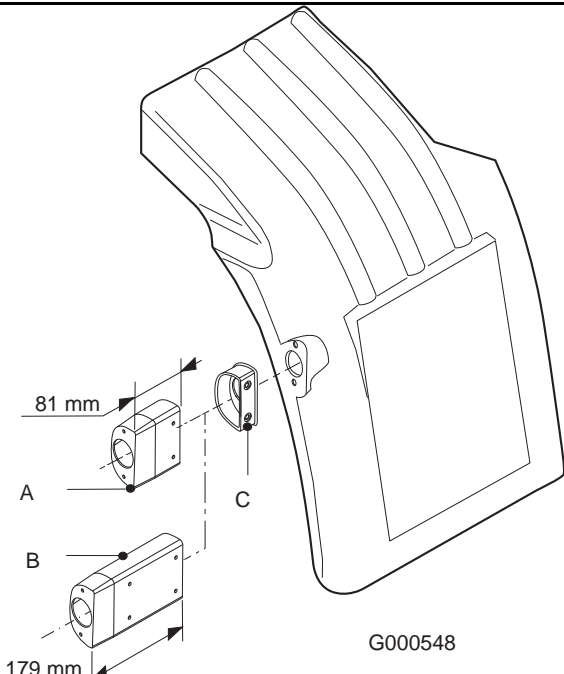











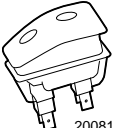

G000548

(1) The approximate overall width over the cab mud guards is for: the LF45 = 2190mm; LF55 12-15t = 2350mm and LF55 18t = 2420mm. The standard wiring loom of the indicator lamps has sufficient length to allow repositioning.

BODYBUILDERS' GUIDELINES

Part numbers

13.8 INDICATION LAMPS

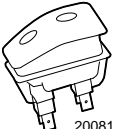
Drawing	Designation	Part number ⁽¹⁾	Lens colour
 20081102-003	Lamp holder (suitable for two lenses)	1395972	
 20070604-020	Loading crane not locked	1399886	Red
 20070604-021	Tail lift open	1399887	Red
 20070604-022	Doors in superstructure open	1399888	Red
 20070604-020	Loading crane active	1399889	Green
 20070604-021	Tail lift active	1399890	Green
 20070604-023	Lock not locked	1399891	Yellow
 20070604-024	PTO 2	1399892	Yellow
 20070604-025	Superstructure lighting	1399893	Yellow
 20070604-026	Spotlights	1399894	Yellow
 20070604-028	Rotating beam	1399895	Yellow
 20070604-027	Trailer lifting gear	1399768	Yellow
 DSYM0254	Tipper body up	1645053	Yellow
	Unmarked lens	0069816	Yellow
	Unmarked lens	0069817	Green
	Unmarked lens	0069818	Red
	Plug (in cases when only one lens is mounted)	1329779	Black
	Holder (Switch like shape) ⁽²⁾ (could be modified to carry a LED lamp)	1409558	-
 20081102-003	Holder + 1 LED Standard suited for 12 V With an additional resistor (470 Ohm) suitable for 24V	1427990	Red

(1) Part numbers suitable for switch locations in CF and XF dashboard and overhead console of the XF105 Super Space Cab.

(2) Part numbers suitable for switch locations in header shelf of LF chassis.

13.9 SWITCHES

Part number ⁽¹⁾	Number of Positions	Description	Colour
1435592	2	switch, on/off	Amber
1339010	2	switch, on/off	Green
1435600	2	switch, on/off with blocking (for PTO), spring-loaded	Amber
1366100	2	switch, on/off with blocking (for PTO), spring-loaded	Green
1435596	3	switch, on1/off/on2	Amber
1339014	3	switch, on1/off/on2	Green
1435597	3	switch, fog lamp, front (and rear)	Amber
1675749	2	switch, on/off + green LED for function indication (pin 9 & 10, 9=+24V)	Amber
1700905 ⁽²⁾	2	switch, on/off for rotating beacons	Amber
1700780 ⁽²⁾	3	switch, on1/off/on2 for sunroof hatch	Amber
1409968 ⁽²⁾	2	switch on/off for night heater	Amber
1322402		lens, PTO	No colour
1322399		lens, work lamp	No colour
1686102		lens, work lamp on roof. For CF and XF series (Comfort and Space cab only)	No colour
1686103		lens, work lamp on roof XF105 series (Super Space Cab only)	No colour

(1) Part numbers suitable for switch locations in the LF, CF and XF dashboard and overhead console of the XF105 Super Space Cab.

(2) Part numbers suitable for switch locations in the LF header shelf.

13.10 CVSG GAUGES

Gauges to be connected on the CVSG data communication bus of the BBM module. For electrical components see chapter 13.13: "Miscellaneous parts".

Metric units (supported by the BBM module)

DAF Part number	Internal reference	Description	Range
1736187	Q43-6002-201C	Primary air pressure	0 - 10 bar
1736188	Q43-6002-202C	Secondary air pressure	0 - 10 bar
1736190	Q43-6002-204C	Engine oil pressure	0 - 7 bar
1736191	Q43-6002-205C	Engine coolant temperature	40 - 120 °C
1736192	Q43-6002-206C	Engine oil temperature	40 - 150 °C
1736193	Q43-6002-207C	Main trans oil temperature	65 - 150 °C

Metric units (not supported by the BBM module)

DAF Part number	Internal reference	Description	Range
1736189	Q43-6002-203C	Application air pressure	0 - 10 bar
1736195	Q43-6002-216C	Transfer case oil temperature	40 - 150 °C

BODYBUILDERS' GUIDELINES

Part numbers

DAF Part number	Internal reference	Description	Range
1736196	Q43-6002-217C	General oil temperature	40 - 150 °C
1736197	Q43-6002-221C	PTO oil temperature	40 - 150 °C

Imperial units (supported by the BBM module)

DAF Part number	Internal reference	Description	Range
1736198	Q43-6002-101C	Primary air pressure	0 - 150 psi
1736207	Q43-6002-102C	Secondary air pressure	0 - 150 psi
1736209	Q43-6002-104C	Engine oil pressure	0 - 100 psi
1736210	Q43-6002-105C	Engine coolant temperature	100 - 250 °F
1736211	Q43-6002-106C	Engine oil temperature	100 - 300 °F
1736212	Q43-6002-107C	Main trans oil temperature	150 - 300 °F

Imperial units (not supported by the BBM module)

DAF Part number	Internal reference	Description	Range
1736208	Q43-6002-103C	Application air pressure	0 - 150 psi
1736213	Q43-6002-121C	PTO oil temperature	100 - 300 °F

General (not supported by the BBM module)

DAF Part number	Internal reference	Description	Range
1736216	Q43-6002-118C	Fuel level #1	E - 1/2 - F
1736222	Not available yet	Voltmeter	18V-36V
1736217	Q43-6002-302C	Ampere	-150A - +150A
1736218	Q43-6002-301C	Hourmeter	0 - 999999 hours
1736219	Q43-6004-301C	Clock	Analog
1736220	Q43-6006-301C	Transmission display (Allison gear-box)	

General

Item	DAF Part number	Remark
1	1736214	
2	1736921	4 pole connector
3	1365147	0,50 to 0,75 mm ²

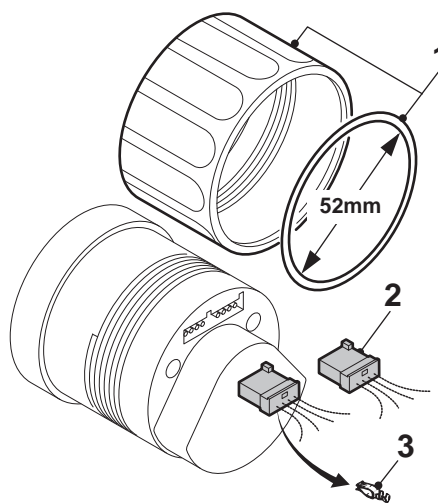

G001191

13.11 ADAPTERS AIR SYSTEM

Screw-in adapter for straight and right-angled pipe fittings				
Model B			Model A	
Type of connection	NG8	NG12	NG8 type SV232	NG12 type SV232
Screw thread	M16 x 1.5	M22 x 1.5	M16 x 1.5	M22 x 1.5
Adapter (A)	0090182	0537162	1377738	1377743
+ clip (B)	0090181	0537161	-	-
+ ring (C)	0090183	0537163	-	-

Straight and right-angled quick-release coupling (pipe fitting) ⁽¹⁾							
G001130				G001131			
Air pipe diameter [mm]	Type of connection	Model A SV230	Model B SV232	Air pipe diameter [mm]	Type of connection	Model C SV230	Model D SV232
6 x 1	NG 8	0090286	1377739	6 x 1	NG 8	0090290	1377741
6 x 1	NG 12	0537169	1377744	6 x 1	NG 12	0537177	1377748
8 x 1	NG 8	1207062	1377757	8 x 1	NG 8	1207061	1377756
8 x 1	NG 12	0537170	1377745	8 x 1	NG 12	0537178	1377749
10 x 1.25	NG 12	0537176	1377747	10 x 1.25	NG 12	0537181	1377751
12 x 1.5	NG 12	0537175	1377746	12 x 1.5	NG 12	0537179	1377750
16 x 2	NG 12	1206819	1377740	16 x 2	NG 12	0090292	1377742

(1) See the product range documentation for any other models.

BODYBUILDERS' GUIDELINES

Part numbers

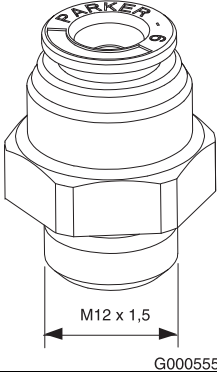
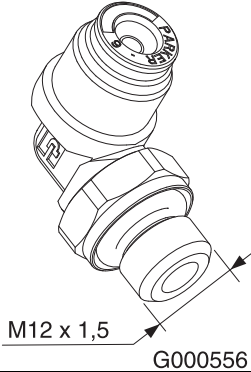
Straight and right-angled coupling (for LF series APU air governor)			
			
Air pipe diameter [mm]		Air pipe diameter [mm]	
6	1409391	6	1408395
8	-	8	1409686
10	1408340	10	1408507

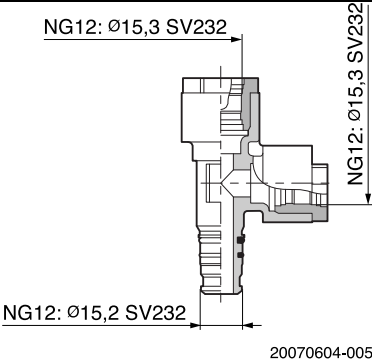
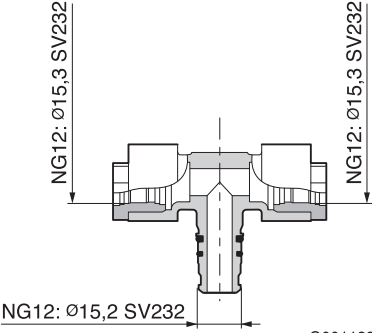
Quick-release tee couplings for various applications	
<p>Tee coupling for: Governor/air distribution unit</p> <p>DAF number: 1377753</p>	
<p>DAF number: 1377752</p>	

Quick-release tee couplings for various applications

DAF number: 1377766

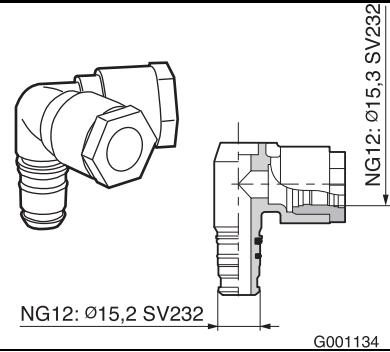

For horn:

DAF nummer: 0529656

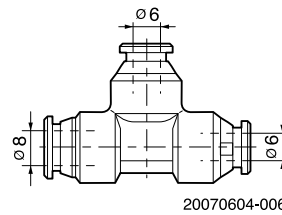

13.12 LOWERED DRAWBAR COMPONENTS

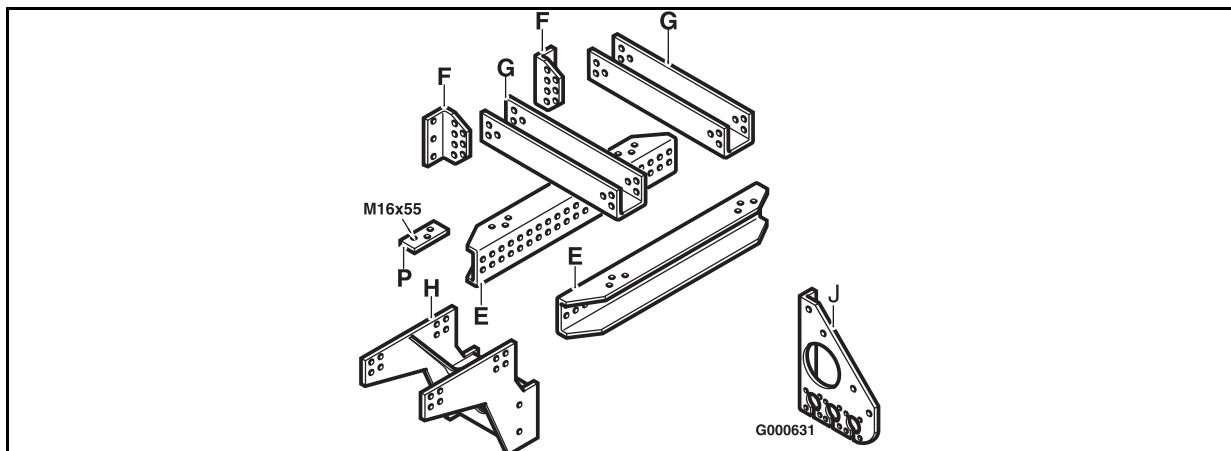

Item	Description	Quantity	Part number	Notes
E	U-shaped profile	2x	1396942	Profile length: 960mm (2x 19 holes)
F	L-shaped support	x	1303464	Used in chassis with inner reinforcement at the rear. Chassis Selco: 4004 (7.0/VA) or 4005 (7.0/DL)
		x	1303465	
		x	1326987	Used in chassis without inner reinforcement at the rear. Chassis Selco: 4000 (7.0/00) or 4002 (7.0/V0)
		x	1326986	
G	Cross member	2x	1303469	U- shape profile
H	Support	1x	1434960	Carrier of drawbar coupling
J	Support	1x	1445143	Chassis support for air and electrical connectors

BODYBUILDERS' GUIDELINES

Part numbers

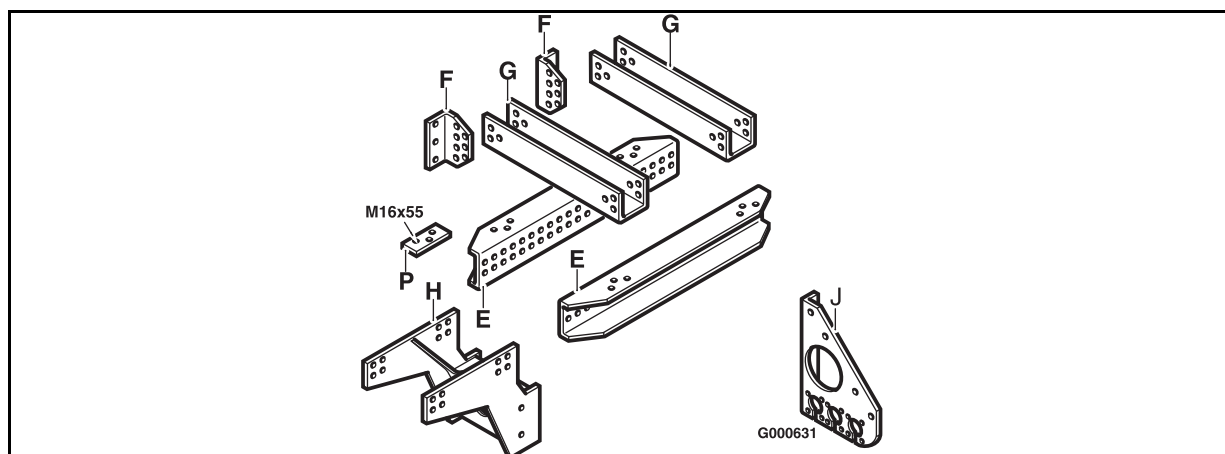

Item	Description	Quantity	Part number	Notes
P	Plate	4x	1314647	Dimensions: 170x 65x 10 mm
-	Flanged nut	76x	1669590	M16 (class 10.9)
-	Flanged bolt	64x	1231064	M16 x 45 mm (class 10.9)
-		3x	1231065	M16 x 50 mm (class 10.9)
		12x	1231066	M16 x 55 mm (class 10.9)

13.13 MISCELLANEOUS PARTS

Chassis sections for chassis extensions: - 45 series 192 x 71 x 4.5 x 3000 - LF 45 series 192 x 66,5x 4.5 x 3000 180 x 47/62 x 4 x 3000 (inner reinforcement) - 55 series 260 x 75 x 6 x 3000 (inner radius: 14 mm) - LF 55 and CF65 ⁽¹⁾series 260 x 75 x 6 x 3000 (inner radius: 12 mm) - CF65 ⁽²⁾, CF75, CF85 and XF series 260 x 75 x 7 x 3000 245 x 65 x 5 x 3600 (inner reinforcement) 310 x 75 x 7 x 3000 295 x 65 x 5 x 3000 (inner reinforcement) - CF85 and XF series 310 x 75 x 8.5 x 3000 292 x 65 x 8.5 x 3000 (inner reinforcement)	KF460 KF460 KF460 KF460 KF460 KF 375 KF 375 KF 375 KF 375 KF 375 KF 375	n/a 1425161 1455544 1308229 1674216 0513777 0668604 0513922 0513926 0513923 n/a
Fuel system: - Quick-release coupling for connecting extra fuel consumers to the fuel tank float. - Air pipe to be used if twin fuel tanks are mounted; length = 10 metres	8 mm PVC (Ø 8 mm internal)	1318421 1399869
Electrical system: Electrical components, converters - 24/12 volts converter - 24/12 volts converter Electrical components for connecting extra batteries - Diode - Mini control relay - Divider relay Electrical components for connecting CVSG gauges - Timer relay (relay switch off after 10 seconds) - Dc-DC converter	max. 10A max. 20A 24V; 20A 24V; 150A 24V; max. 5A 24V-12V / 10 Amp	1368353 1368354 0629678 1745069 1347161 1651907 1726283
PTO flanges: - Flange, 6-hole (DIN 75) for ZF PTO - Flange, 4-hole (DIN 90) for ZF PTO - Flange, 6-hole (DIN 100) for ZF PTO - Flange, 8-hole (DIN 120) for ZF PTO - Flange, 6-hole (DIN 100) for Chelsea PTO		0586358 0208296 0140796 0258518 1408266
Fifth wheel base plates: - Base plate (pre-drilled) ⇒ KA dimension adjustment pitches of 25 mm	Height 12 mm Height 26 mm Height 40 mm Height 80 mm Height 120 mm	1377195 1377193 1377192 1377186 (1x) 1377185 (1x) 1377592 (1x) 1377593 (1x)
- Fifth wheel base plate (pre-drilled) ⇒ 3 KA dimensions are possible: KA = 470, 520 and 570 mm	Height 12 mm (FT Low Deck)	1377194

BODYBUILDERS' GUIDELINES

Part numbers

- (1) CF65 chassis produced from week 0513 onwards (V.I.N. code: XLRAE65CC0E677039).
- (2) CF65 chassis produced up to and including week 0512.

REACTION FORM

	Page	Date
Feedback form.....	425	201019

BODYBUILDERS' GUIDELINES

Reaction form

14. REACTION FORM

Feedback form

To help maintain the present level of quality and user-friendliness of the DAF Bodybuilders' Guidelines and the information given in this manual, I would like to submit the following recommendations and/or suggestions.

Section:

.....
.....
.....
.....
.....
.....
.....
.....
.....

Subject:

.....
.....
.....
.....
.....
.....
.....
.....
.....

Suggestions:

.....
.....
.....
.....
.....
.....
.....
.....
.....

Please send to:

DAF Trucks N.V.
Truck Logistics, Sales Engineering dept.
Building C0801100
Hugo van der Goeslaan
PO Box 90065
5600 PT
Eindhoven

Fax: +31 (0) 40 2143924

Sender:

.....
.....
.....
.....
.....
.....
.....
.....
.....
.....



No rights can be derived from this publication.
DAF Trucks N.V. reserves the right to change
product specifications without prior notice.
Products and services comply with the European
Directives effective at the time of sale but may
vary depending on the country in which you are located.

For the most recent information
contact your authorized DAF Dealer

DAF Trucks N.V.
Hugo van der Goeslaan 1
P.O. Box 90065
5600 PT Eindhoven
The Netherlands
Tel.: +31 (0) 40 21 49 111
Fax: +31 (0) 40 21 44 325
www.daf.com

driven by quality



ISO14001
Environmental
Management System



ISO/TS16949
Quality
Management System

DAF
A PACCAR COMPANY